

# Solid State Relays 1-Phase with Integrated Current Monitoring Types RGC1S, RGS1S

CARLO GAVAZZI



- Product width ranging from 22.5mm to 70mm
- Available with or without integrated heatsink
- Partial load failure detection
- Zero cross switching
- Ratings up to 600VACrms & 85AACrms @ 40°C
- Up to 6600A<sup>2</sup>s for I<sup>2</sup>t and 1200Vp for blocking voltage
- Control voltage range : 4 - 32 VDC
- Local or remote current set-point
- LED indications for the different faults
- Alarm signal output for SSR or load circuit malfunction
- IP20 protection
- Integrated voltage transient protection with varistor
- RoHS compliant
- Short circuit current rating 100kArms

## Product Description

This slim RG design is capable of detecting various failure modes occurring to the heaters and also to the product itself. Failures which can be detected include partial load failure, heater loss, open circuit SSR, short circuit SSR and SSR over temperature. A normally closed, potential free alarm, opens in the event of a system or power semiconductor fault.

A load current setpoint has to be TEACHed to the SSR either locally by the TEACH button

on the front of the device or remotely through the provided terminal.

This product is available either with integrated heatsink (RGC1S series) and also without heatsink (RGS1S series). The minimum product width is 22.5mm. The control and auxiliary terminals are double box clamps to facilitate safe looping whilst the power terminals are either screw terminals or box clamps depending on the model selected.

Note: Specifications stated at 25°C unless specified.

## Ordering Key

**RGC 1 S 60 D 30 G K E P \_**

Solid state relay	_____
Number of poles	_____
Switching mode	_____
Rated operational voltage	_____
Control voltage	_____
Rated operational current	_____
Connection type for control	_____
Connection type for power	_____
Connection configuration	_____
Protection	_____
Options	_____

## Ordering Key

1-Phase SSR	Switching mode	Rated V, Blocking V*	Control voltage	Rated current <sup>1</sup> @ 40°C I <sup>2</sup> t data	Connection input	Connection output	Connection configuration	Protection
RGC1: with heatsink	S: Zero cross with current sensing	60:600VAC +10% -15%, 1200Vp	D: 4-32VDC	20: 23AAC, 525A <sup>2</sup> s 25: 23AAC, 1800A <sup>2</sup> s 30: 30AAC, 1800A <sup>2</sup> s 31: 30AAC, 6600A <sup>2</sup> s 41: 40AAC, 6600A <sup>2</sup> s 61: 60AAC, 6600A <sup>2</sup> s 90: 85AAC, 6600A <sup>2</sup> s	G: Box Clamp	K: Screw G: Box Clamp	E: Contactor U: SSR	P: Over-temperature protection
RGS1: with no heatsink								

\* Rated voltage, Blocking voltage

1: refer to derating curves for RGC models and heatsink selection tables for RGS models



## Selection Guide: RGC1S (with integrated heatsink)

Rated output voltage, Blocking voltage	Connection control/ power	Control voltage	Configuration	Rated operational current (I <sub>t</sub> value in brackets)			
				23AAC (525A <sup>2</sup> s)	23AAC (1800A <sup>2</sup> s)	30AAC (1800A <sup>2</sup> s)	30AAC (6600A <sup>2</sup> s)
600VAC, 1200Vp	Box Clamp/ Screw	4 - 32VDC	E	RGC1S60D20GKEP	RGC1S60D25GKEP	RGC1S60D30GKEP	RGC1S60D31GKEP

Rated output voltage, Blocking voltage	Connection control/ power	Control voltage	Configuration	Rated operational current (I <sub>t</sub> value in brackets)		
				40AAC (6600A <sup>2</sup> s)	60AAC (6600A <sup>2</sup> s)	85AAC (6600A <sup>2</sup> s)
600VAC, 1200Vp	Box Clamp/ Box Clamp	4 - 32VDC	E U	RGC1S60D41GGEP RGC1S60D41GGUP	RGC1S60D61GGEP RGC1S60D61GGUP	RGC1S60D90GGEP -

## Selection Guide: RGS1S (with no heatsink)

Rated output voltage, Blocking voltage	Connection control/ power	Control voltage	Configuration	Rated operational current (I <sub>t</sub> value in brackets)		
				23AAC (525A <sup>2</sup> s)	30AAC (1800A <sup>2</sup> s)	30AAC (6600A <sup>2</sup> s)
600VAC, 1200Vp	Box Clamp / Screw	4 - 32VDC	E	RGS1S60D20GKEP	RGS1S60D30GKEP	RGS1S60D31GKEP

Rated output voltage, Blocking voltage	Connection control/ power	Control voltage	Configuration	Rated operational current (I <sub>t</sub> value in brackets)
				60AAC (6600A <sup>2</sup> s)
600VAC, 1200Vp	Box Clamp/ Box Clamp	4 - 32VDC	E U	RGS1S60D61GGEP RGS1S60D61GGUP

## Output Voltage Specifications

Operational Voltage Range	42-600 VAC +10% -15% on max
Blocking Voltage	1200 Vp
Internal Varistor	625V

## Output Specifications

	RGC1S..20 RGS1S..20	RGC1S..25	RGC1S..30 RGS1S..30	RGC1S..31 RGS1S..31	RGC1S..41	RGC1S..61 RGS1S..61	RGC1S..90
Rated operational current <sup>2</sup>							
AC-51 @ Ta=25°C RGC1S	25.5 AAC	23.8 AAC	30 AAC	30 AAC	49 AAC	75 AAC	85 AAC
AC-51 @ Ta=40°C RGC1S	23 AAC	23.8 AAC	30 AAC	30 AAC	40 AAC	60 AAC	85 AAC
Max. AC-51 rating RGS1S	23 AAC	n/a	30 AAC	30 AAC	n/a	60 AAC	n/a
Minimum TEACH Current <sup>3</sup>	1.2 AAC	1.2 AAC	1.2 AAC	1.2 AAC	1.2 AAC	5 AAC	5 AAC
Minimum partial load current	0.2 AAC	0.2 AAC	0.2 AAC	0.2 AAC	0.2 AAC	0.83 AAC	0.83 AAC
Detectable partial load failure	>16.67% from current setpoint for more than 120ms						
Rep. overload current - UL508, PF=0.9							
TAMB=40°C, tON=1s, tOFF=9s, 50cycles	60 AAC	60 AAC	84 AAC	84 AAC	126 AAC	144 AC	168 AAC
Max.off-state leakage current	3 mAAC	3 mAAC	3 mAAC	3 mAAC	3 mAAC	3 mAAC	3 mAAC
Max. Transient Surge Current (I <sub>tsm</sub> ) t=10ms	325 Ap	600 Ap	600 Ap	1150 Ap	1150 Ap	1150 Ap	1150 Ap
I <sup>2</sup> t for fusing (t=10ms) Minimum	525 A <sup>2</sup> s	1800 A <sup>2</sup> s	1800 A <sup>2</sup> s	6600 A <sup>2</sup> s	6600 A <sup>2</sup> s	6600 A <sup>2</sup> s	6600 A <sup>2</sup> s
Critical dv/dt (@ T <sub>j</sub> init = 40°C)	1000 V/us	1000 V/us	1000 V/us	1000 V/us	1000 V/us	1000 V/us	1000 V/us

2: refer to derating curves for RGC models and heatsink selection tables for RGS models

3: refer to EMC specifications

## General Specifications

Latching voltage (across L1-T1)	≤ 20 VAC	Pollution degree	2 (non-conductive pollution with possibilities of condensation)
Operational frequency range	45 - 65 Hz	Over-voltage category	III (fixed installations)
Power factor	> 0.5 @ Vrated	Isolation Input to Output IN1, IN2, A1+, A2- to L1, T1	2500Vrms
Touch protection	IP20	Alarm to Output 11+, 12- to L1, T1	2500Vrms
LEDs status indication		Alarm to Input 11+, 12- to A1+, A2-, IN1, IN2	500Vrms
Supply ON	Green, half intensity	Input & Output to Case	4000Vrms
Control ON	Green, full intensity		
Load ON	Yellow		
Fault	Red <sup>4</sup>		

## Supply Specifications (A1+, A2-)

Rated supply voltage	24 VDC -15%, +20%
Reverse protection	Yes
Max. supply current	50 mA
Fan supply RGC1S..90	Supplied directly to fan 24VDC +/-10%, 50mA nominal

## Remote TEACH Specifications (IN1)

Control voltage range <sup>5</sup>	4 - 32 VDC
Input current	refer to chart
Reverse protection	Yes

## Alarm Specifications (11+, 12-)

Output Type	PNP Open Collector
Normal State <sup>6</sup>	Normally Closed
Maximum rating	35Vdc, 50mADC
Visual Indication	Red LED <sup>4</sup>
Alarm output onstate voltage	refer to chart

## Control Specifications (IN2)

Control voltage range <sup>5,7</sup>	4 - 32 VDC
Pick-up voltage	3.8 VDC
Drop-out voltage	1 VDC
Maximum reverse voltage	32 VDC
Input current	refer to chart
Max Response time pick-up	0.5 cycle + 500us @ 24VDC
Min Response time drop-out	0.5 cycle + 500us @ 24VDC

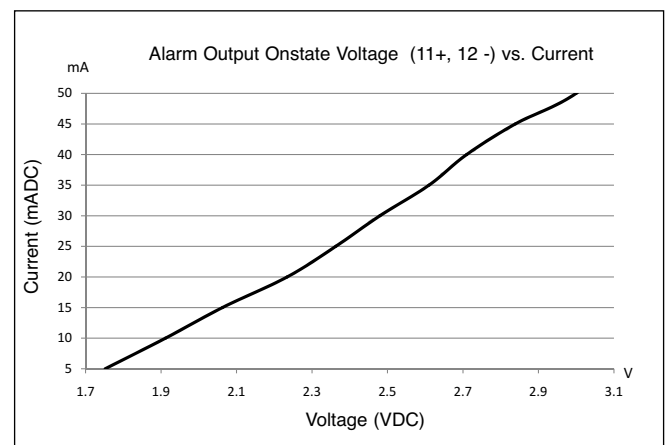
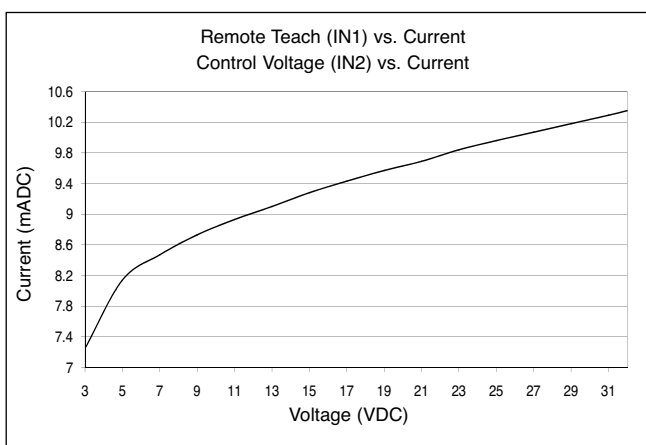

4: refer to Alarm LED Indications

5: DC control to be supplied by a Class 2 power source

6: The alarm will open in the case when the power supply is removed

7: Minimum duty cycle is 120ms ON, 120ms OFF

The duty cycle must allow for stabilisation of load current in order to have a correct current set point

## Output Power Dissipation

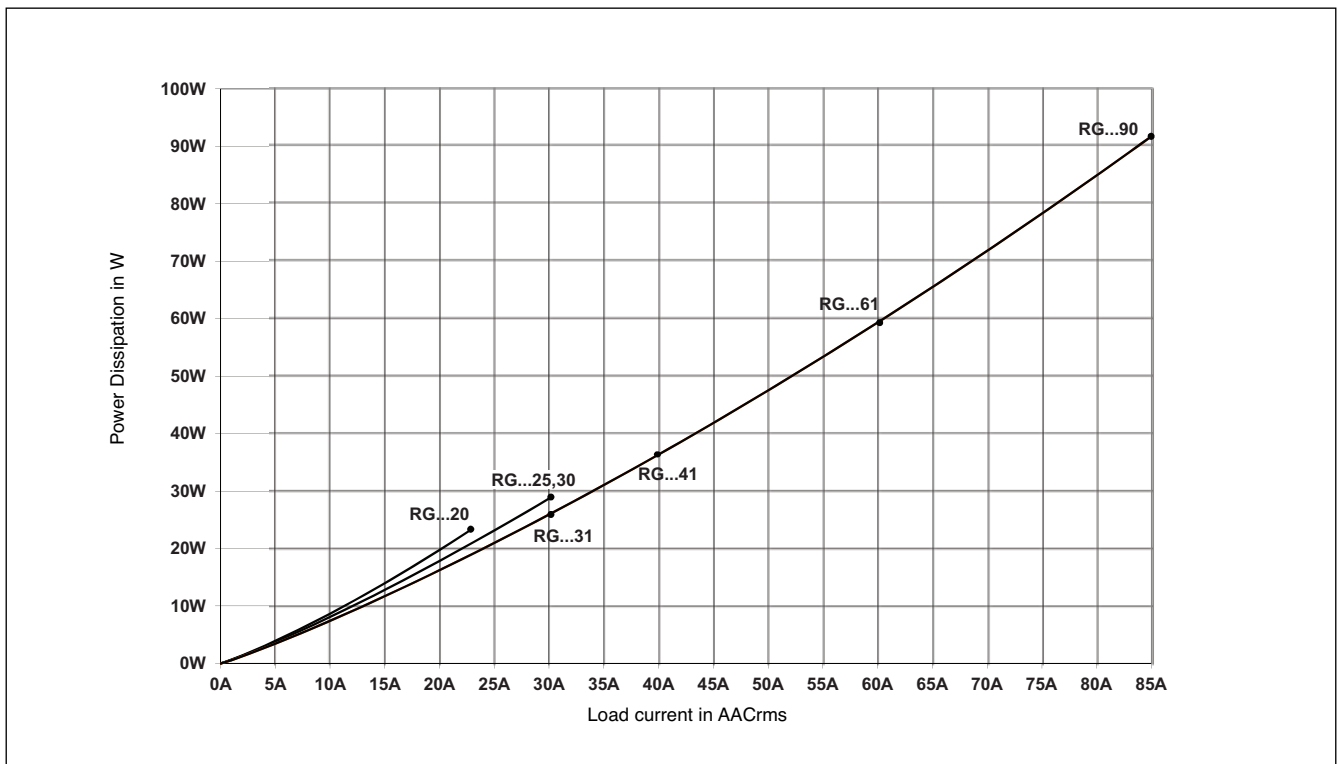

## Current Derating (UL508) for RGC1S

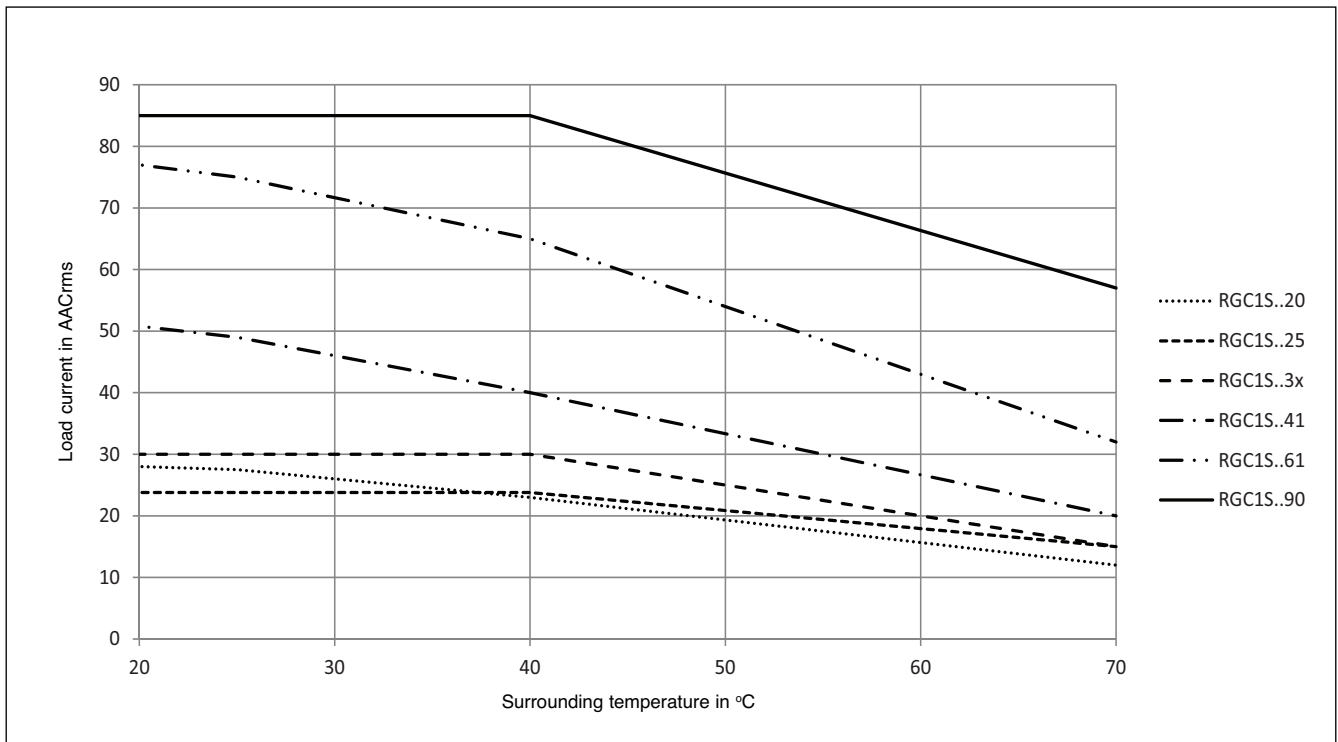

## Derating vs. Spacing Curves for RGC1S

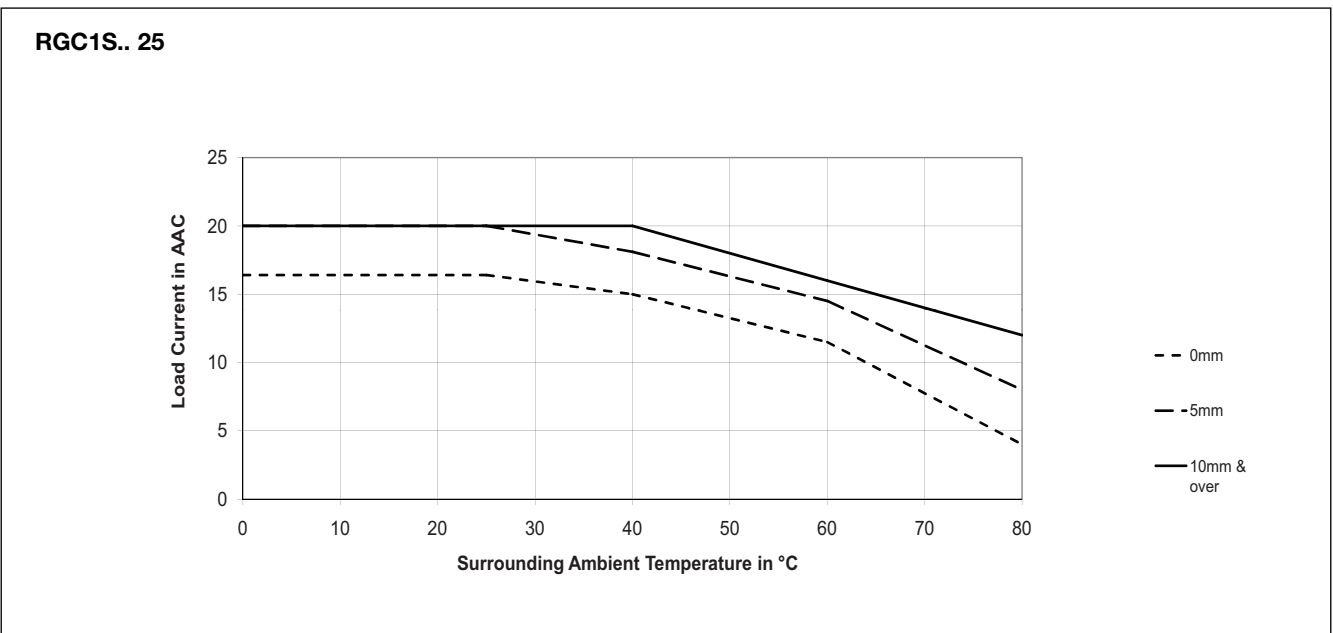
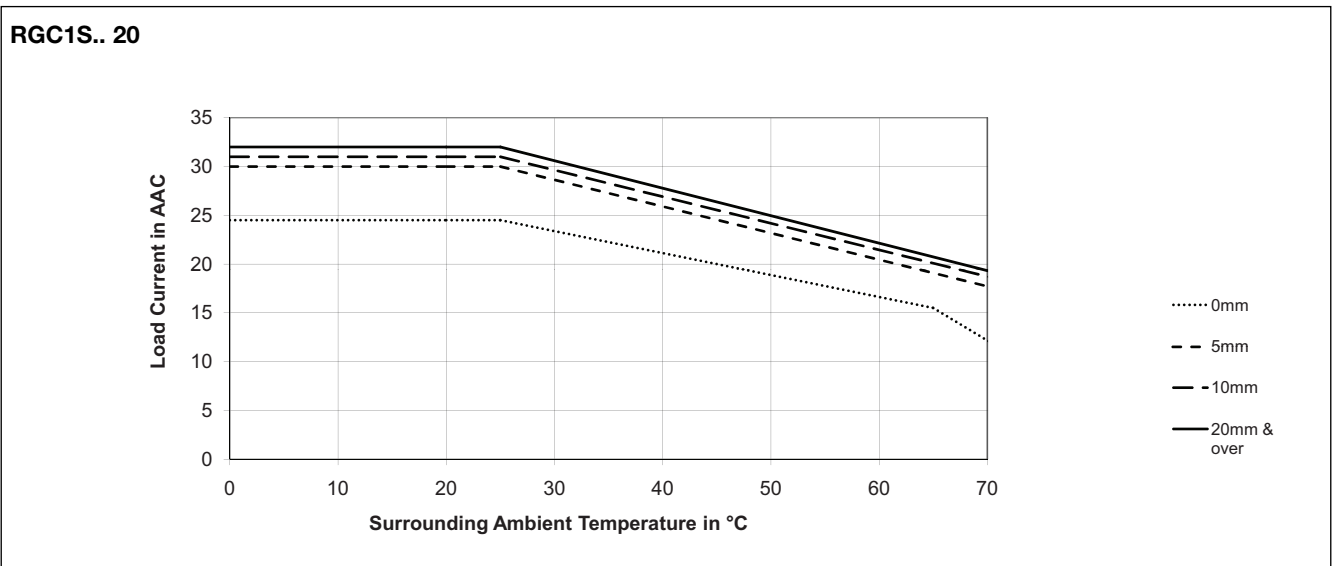

## Derating vs. Spacing Curves for RGC1S

RGC1S.. 30

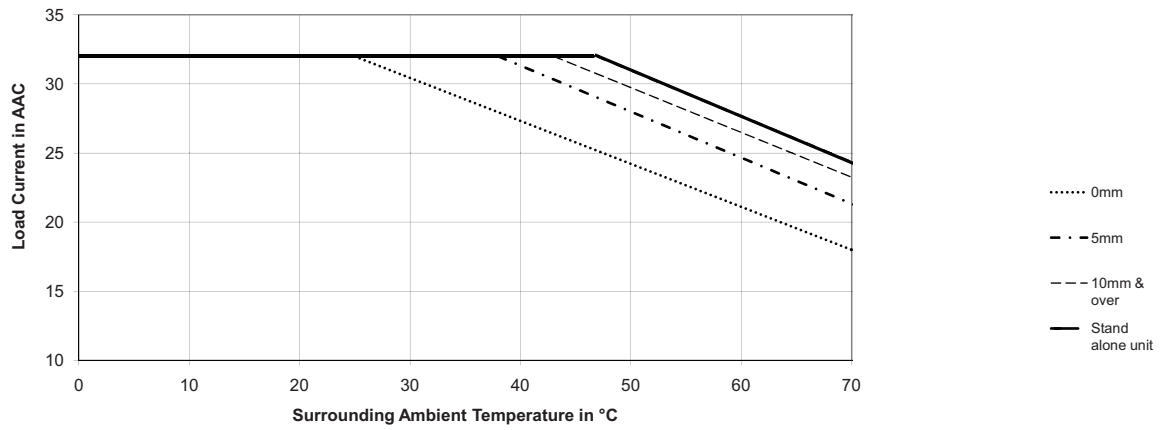

RGC1S.. 31

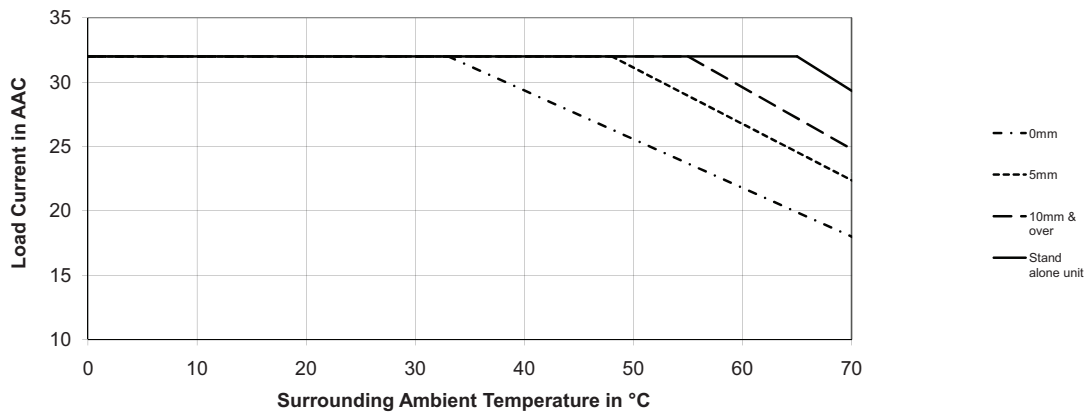

## Derating vs. Spacing Curves for RGC1S

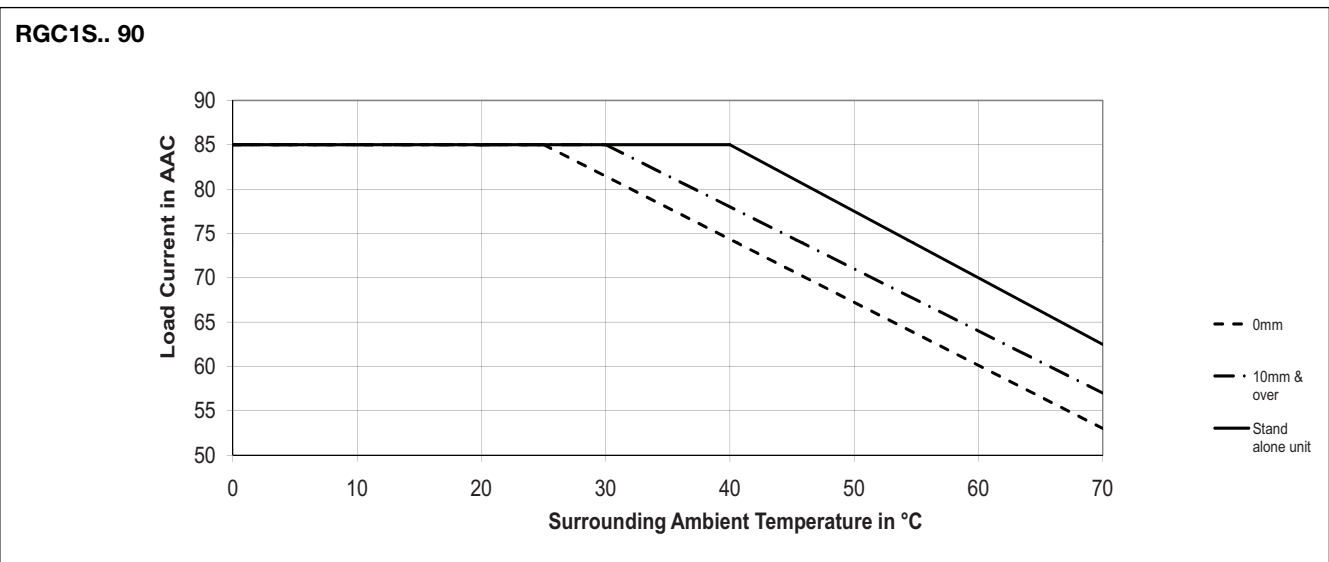
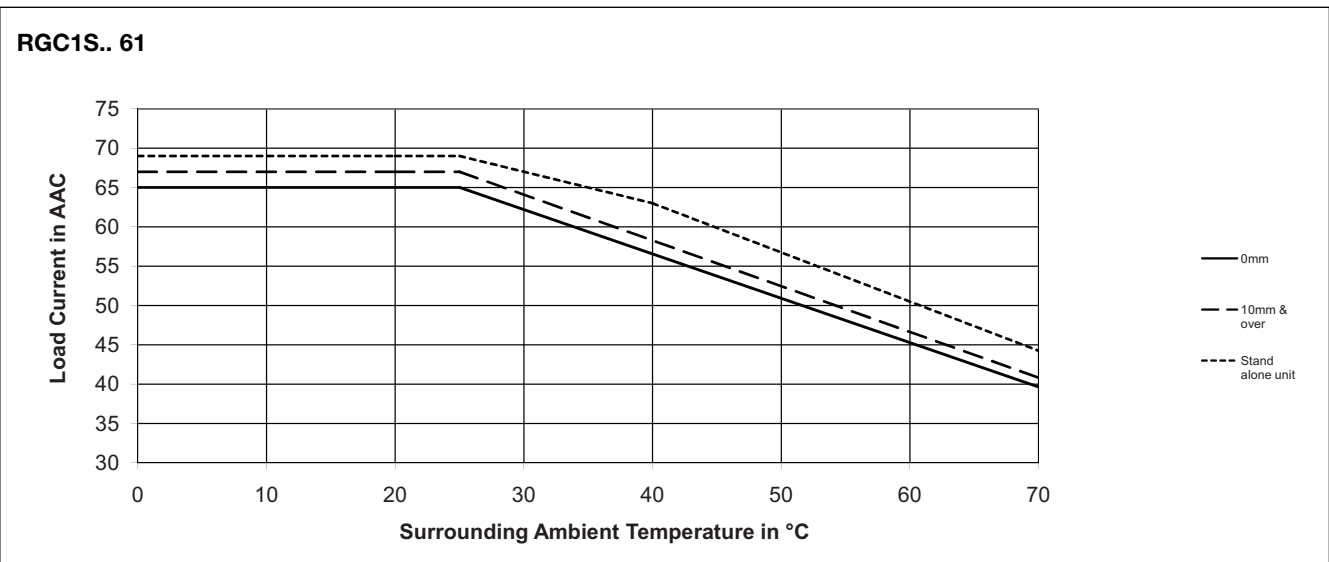
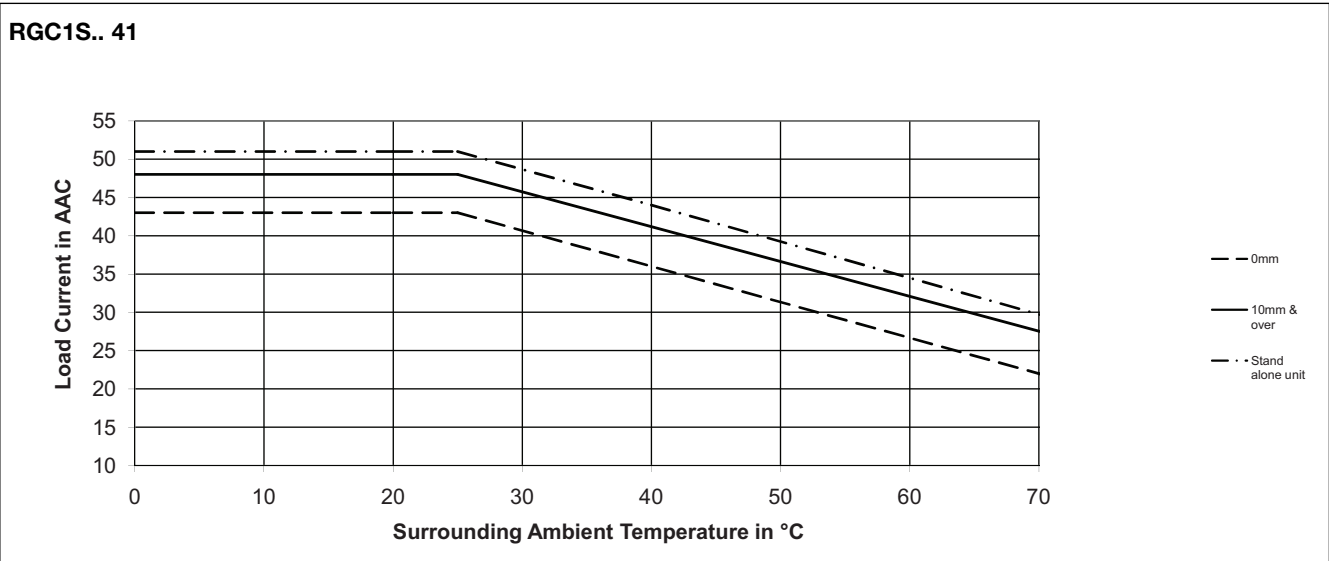



# Heatsink Selection for RGS1S

## RGS1S60D20GKEP

Load current [A]	Thermal resistance [K/W]						Power dissipation [W]
	20	30	40	50	60	70	
23.0	3.45	3.02	2.59	2.16	1.73	1.29	23.2
20.7	3.93	3.44	2.95	2.46	1.97	1.48	20.3
18.4	4.55	3.98	3.41	2.84	2.27	1.70	17.6
16.1	5.35	4.68	4.01	3.34	2.67	2.01	15.0
13.8	6.44	5.63	4.83	4.02	3.22	2.41	12.4
11.5	8.00	7.00	6.00	5.00	4.00	3.00	10.0
9.2	10.39	9.09	7.79	6.50	5.20	3.90	7.7
6.9	14.50	12.69	10.88	9.07	7.25	5.44	5.5
4.6	23.06	20.18	17.29	14.41	11.53	8.65	3.5
2.3	50.39	44.09	37.79	31.49	25.20	18.90	1.6

T<sub>A</sub>  
Ambient temp [°C]

## RGS1S60D30GKEP

Load current [A]	Thermal resistance [K/W]						Power dissipation [W]
	20	30	40	50	60	70	
32.0	2.62	2.29	1.97	1.64	1.31	0.98	30.5
28.8	2.98	2.60	2.23	1.86	1.49	1.12	26.9
25.6	3.43	3.00	2.57	2.14	1.71	1.29	23.3
22.4	4.01	3.51	3.01	2.51	2.01	1.51	19.9
19.2	4.81	4.21	3.61	3.01	2.41	1.80	16.6
16.0	5.94	5.20	4.46	3.71	2.97	2.23	13.5
12.8	7.69	6.73	5.76	4.80	3.84	2.88	10.4
9.6	10.68	9.34	8.01	6.67	5.34	4.00	7.5
6.4	16.89	14.78	12.67	10.56	8.45	6.33	4.7
3.2	36.77	32.17	27.58	22.98	18.38	13.79	2.2

T<sub>A</sub>  
Ambient temp [°C]

Maximum junction temperature	125° C
Heatsink temperature	100° C
Junction to case thermal resistance, R <sub>thjc</sub>	<0.45 K/W
Case to heatsink thermal resistance, R <sub>thcs</sub> <sup>8</sup>	< 0.25 K/W

Maximum junction temperature	125° C
Heatsink temperature	100° C
Junction to case thermal resistance, R <sub>thjc</sub>	<0.3 K/W
Case to heatsink thermal resistance, R <sub>thcs</sub> <sup>8</sup>	< 0.25 K/W

## RGS1S60D31GKEP

Load current [A]	Thermal resistance [K/W]						Power dissipation [W]
	20	30	40	50	60	70	
23.0	2.91	2.54	2.18	1.82	1.45	1.09	27.5
28.8	3.29	2.88	2.47	2.06	1.65	1.23	24.3
25.6	3.78	3.30	2.83	2.36	1.89	1.42	21.2
22.4	4.41	3.86	3.31	2.76	2.21	1.65	18.1
19.2	5.27	4.61	3.95	3.29	2.63	1.98	15.2
16.0	6.49	5.68	4.87	4.06	3.25	2.44	12.3
12.8	8.37	7.32	6.28	5.23	4.19	3.14	9.6
9.6	11.59	10.14	8.69	7.24	5.79	4.34	6.9
6.4	18.26	15.98	13.70	11.41	9.13	6.85	4.4
3.2	39.58	34.63	29.69	24.74	19.79	14.84	2.0

T<sub>A</sub>  
Ambient temp [°C]

## RGS1S60D61GG.P

Load current [A]	Thermal resistance [K/W]						Power dissipation [W]
	20	30	40	50	60	70	
60.0	1.33	1.16	0.99	0.82	0.65	0.48	58.9
54.0	1.55	1.35	1.16	0.97	0.77	0.58	51.7
48.0	1.79	1.56	1.34	1.12	0.89	0.67	44.7
42.0	2.10	1.84	1.58	1.31	1.05	0.79	38.1
36.0	2.53	2.21	1.90	1.58	1.26	0.95	31.6
30.0	3.14	2.74	2.35	1.96	1.57	1.18	25.5
24.0	4.07	3.56	3.05	2.54	2.04	1.53	19.6
18.0	5.67	4.97	4.26	3.55	2.84	2.13	14.1
12.0	9.01	7.88	6.75	5.63	4.50	3.38	8.9
6.0	19.63	17.18	14.72	12.27	9.81	7.36	4.1

T<sub>A</sub>  
Ambient temp [°C]

Maximum junction temperature	125° C
Heatsink temperature	100° C
Junction to case thermal resistance, R <sub>thjc</sub>	<0.2 K/W
Case to heatsink thermal resistance, R <sub>thcs</sub> <sup>8</sup>	< 0.25 K/W

Maximum junction temperature	125° C
Heatsink temperature	100° C
Junction to case thermal resistance, R <sub>thjc</sub>	<0.2 K/W
Case to heatsink thermal resistance, R <sub>thcs</sub> <sup>8</sup>	< 0.25 K/W

8: Thermal resistance case to heatsink values are applicable upon application of a fine layer of silicon based thermal paste HT02S from Electrolube between SSR and heatsink.



## Heatsink Selection for RGS1S...HT

RGS1S...HT: RGS1S.. with attached thermal pad. Available upon request.

### RGS1S60D20GKEPHT

Load current [A]	Thermal resistance [K/W]						Power dissipation [W]
	20	30	40	50	60	70	
23.0	3.18	2.75	2.32	1.88	1.45	1.02	23.2
20.7	3.81	3.32	2.83	2.34	1.85	1.35	20.3
18.4	4.55	3.98	3.41	2.84	2.27	1.70	17.6
16.1	5.35	4.68	4.01	3.34	2.67	2.01	15.0
13.8	6.44	5.63	4.83	4.02	3.22	2.41	12.4
11.5	8.00	7.00	6.00	5.00	4.00	3.00	10.0
9.2	10.39	9.09	7.79	6.50	5.20	3.90	7.7
6.9	14.50	12.69	10.88	9.07	7.25	5.44	5.5
4.6	23.08	20.18	17.29	14.41	11.53	8.65	3.5
2.3	50.39	44.09	37.79	31.49	25.20	18.90	1.6

T<sub>A</sub>  
Ambient temp [°C]

Maximum junction temperature	125°C
Heatsink temperature	100°C
Junction to case thermal resistance, R <sub>thjc</sub>	<0.45 K/W
Case to heatsink thermal resistance, R <sub>thcs</sub>	< 0.9 K/W

### RGS1S60D30GKEPHT

Load current [A]	Thermal resistance [K/W]						Power dissipation [W]
	20	30	40	50	60	70	
32.0	2.29	1.96	1.64	1.31	0.98	0.65	30.5
28.8	2.76	2.39	2.01	1.64	1.27	0.90	26.9
25.6	3.35	2.92	2.49	2.06	1.63	1.21	23.3
22.4	4.01	3.51	3.01	2.51	2.01	1.51	19.9
19.2	4.81	4.21	3.61	3.01	2.41	1.80	16.6
16.0	5.94	5.20	4.46	3.72	2.97	2.23	13.5
12.8	7.69	6.73	5.77	4.80	3.84	2.88	10.4
9.6	10.68	9.34	8.01	6.67	5.34	4.00	7.5
6.4	16.89	14.78	12.67	10.56	8.45	6.33	4.7
3.2	36.77	32.17	27.58	22.98	18.38	13.79	2.2

T<sub>A</sub>  
Ambient temp [°C]

Maximum junction temperature	125°C
Heatsink temperature	100°C
Junction to case thermal resistance, R <sub>thjc</sub>	<0.3 K/W
Case to heatsink thermal resistance, R <sub>thcs</sub>	< 0.85 K/W

### RGS1S60D31GKEPHT

Load current [A]	Thermal resistance [K/W]						Power dissipation [W]
	20	30	40	50	60	70	
32.0	2.82	2.45	2.09	1.73	1.36	1.00	27.5
28.8	3.29	2.88	2.47	2.06	1.65	1.23	24.3
25.6	3.78	3.30	2.83	2.36	1.89	1.42	21.2
22.4	4.41	3.86	3.31	2.76	2.21	1.65	18.1
19.2	5.27	4.61	3.95	3.29	2.63	1.98	15.2
16.0	6.49	5.68	4.87	4.06	3.25	2.44	12.3
12.8	8.37	7.32	6.28	5.23	4.19	3.14	9.6
9.6	11.59	10.14	8.69	7.24	5.79	4.34	6.9
6.4	18.26	15.98	13.70	11.41	9.13	6.85	4.4
3.2	39.58	34.63	29.69	24.74	19.79	14.84	2.0

T<sub>A</sub>  
Ambient temp [°C]

Maximum junction temperature	125°C
Heatsink temperature	100°C
Junction to case thermal resistance, R <sub>thjc</sub>	<0.2 K/W
Case to heatsink thermal resistance, R <sub>thcs</sub>	< 0.8 K/W

### RGS1S60D61GG.PHT

Load current [A]	Thermal resistance [K/W]						Power dissipation [W]
	20	30	40	50	60	70	
60.0	0.78	0.61	0.44	0.27	0.10	---	58.9
54.0	1.03	0.84	0.65	0.45	0.26	0.06	51.7
48.0	1.35	1.12	0.90	0.68	0.45	0.23	44.7
42.0	1.76	1.50	1.23	0.97	0.71	0.45	38.1
36.0	2.32	2.00	1.69	1.37	1.05	0.74	31.6
30.0	3.12	2.72	2.33	1.94	1.55	1.16	25.5
24.0	4.07	3.56	3.05	2.54	2.04	1.53	19.6
18.0	5.67	4.97	4.26	3.5	2.84	2.13	14.1
12.0	9.01	7.88	6.75	5.63	4.50	3.38	8.9
6.0	19.63	17.18	14.72	12.27	9.81	7.36	4.1

T<sub>A</sub>  
Ambient temp [°C]

Maximum junction temperature	125°C
Heatsink temperature	100°C
Junction to case thermal resistance, R <sub>thjc</sub>	<0.2 K/W
Case to heatsink thermal resistance, R <sub>thcs</sub>	< 0.8 K/W

## Terminal Markings

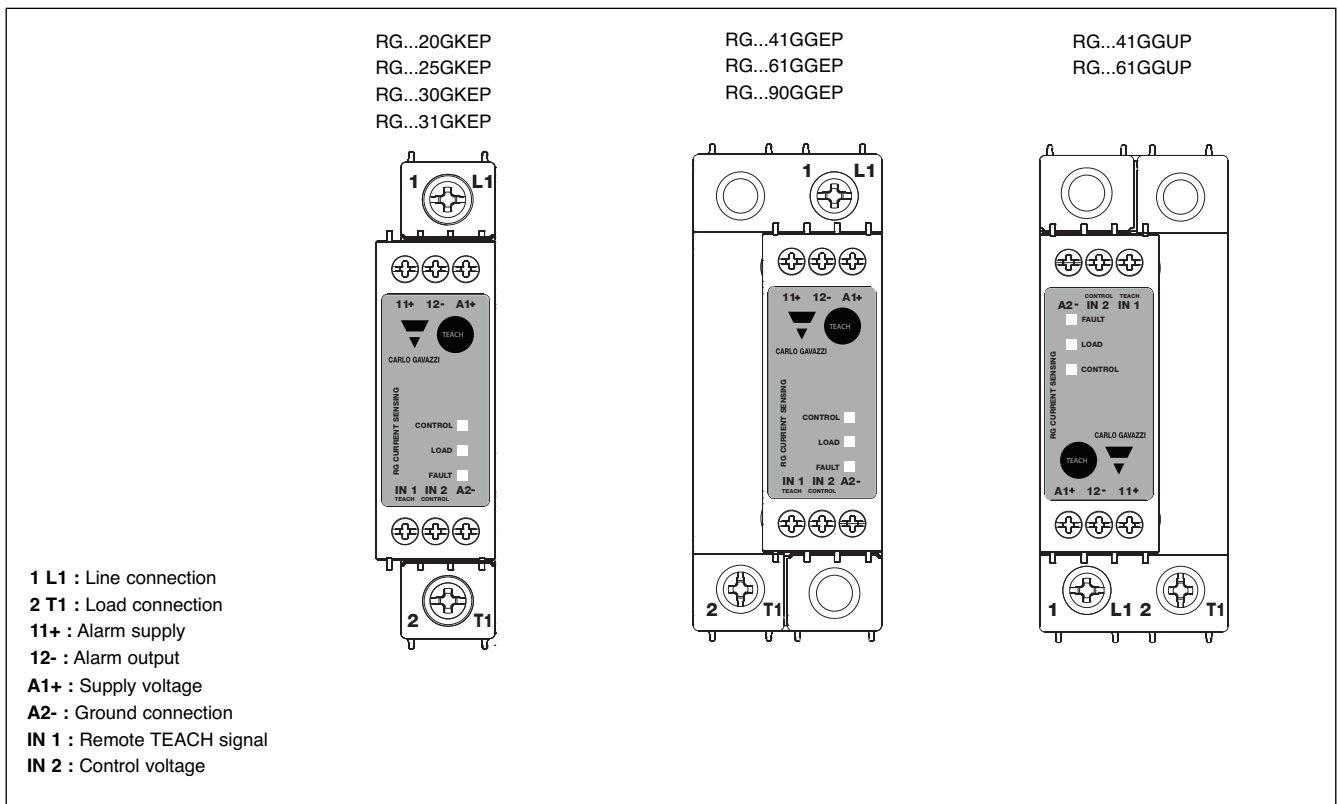

Note:  
 - Local TEACH by pressing front button for more than 3 sec but less than 5 sec  
 - Fan supply (24VDC) for RGC1A60D90GGEP has to be supplied directly to fan

## Connection Diagram

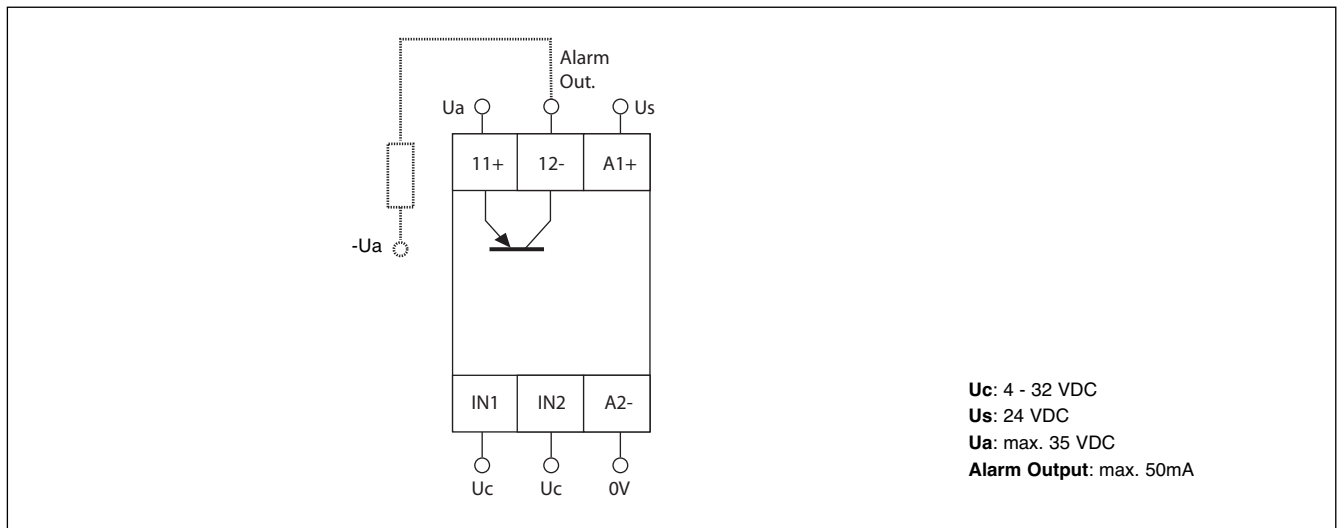



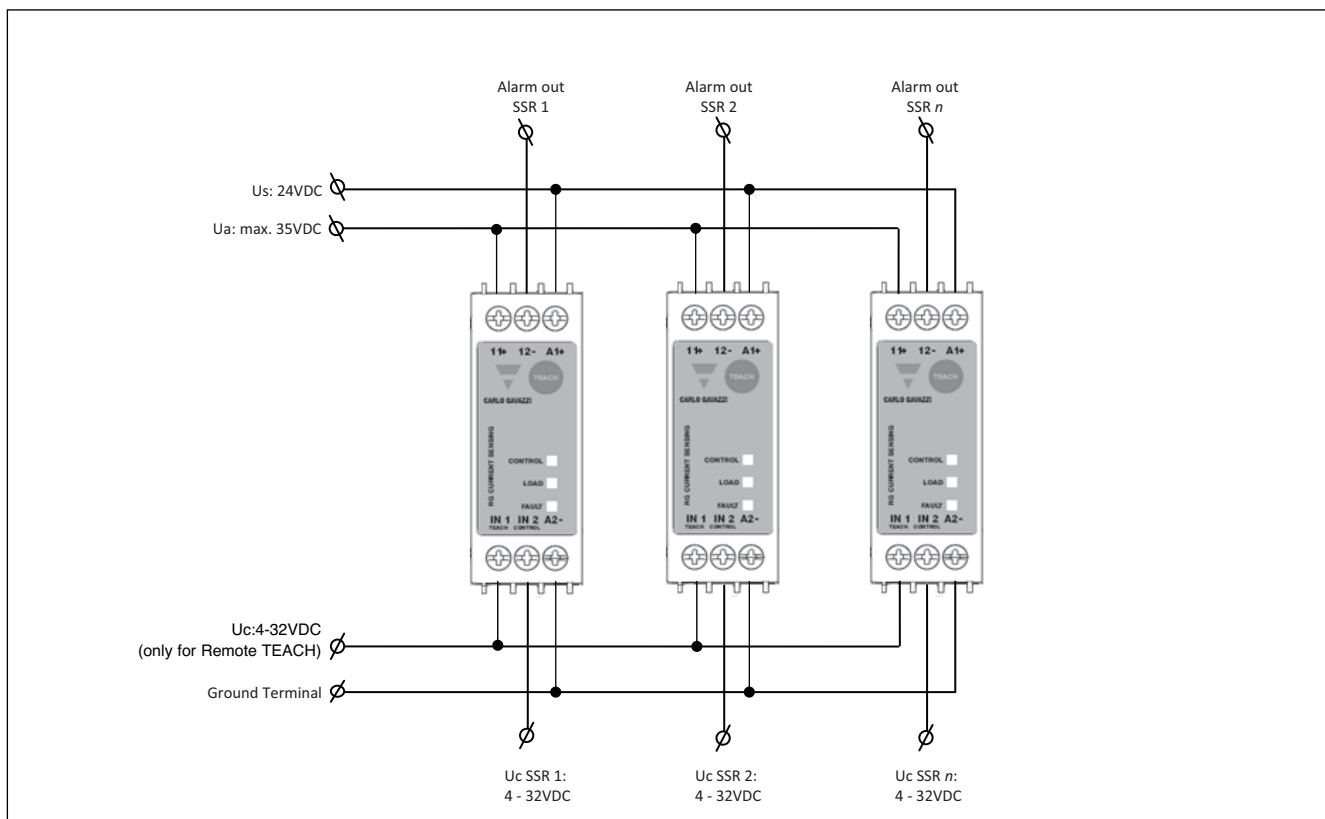

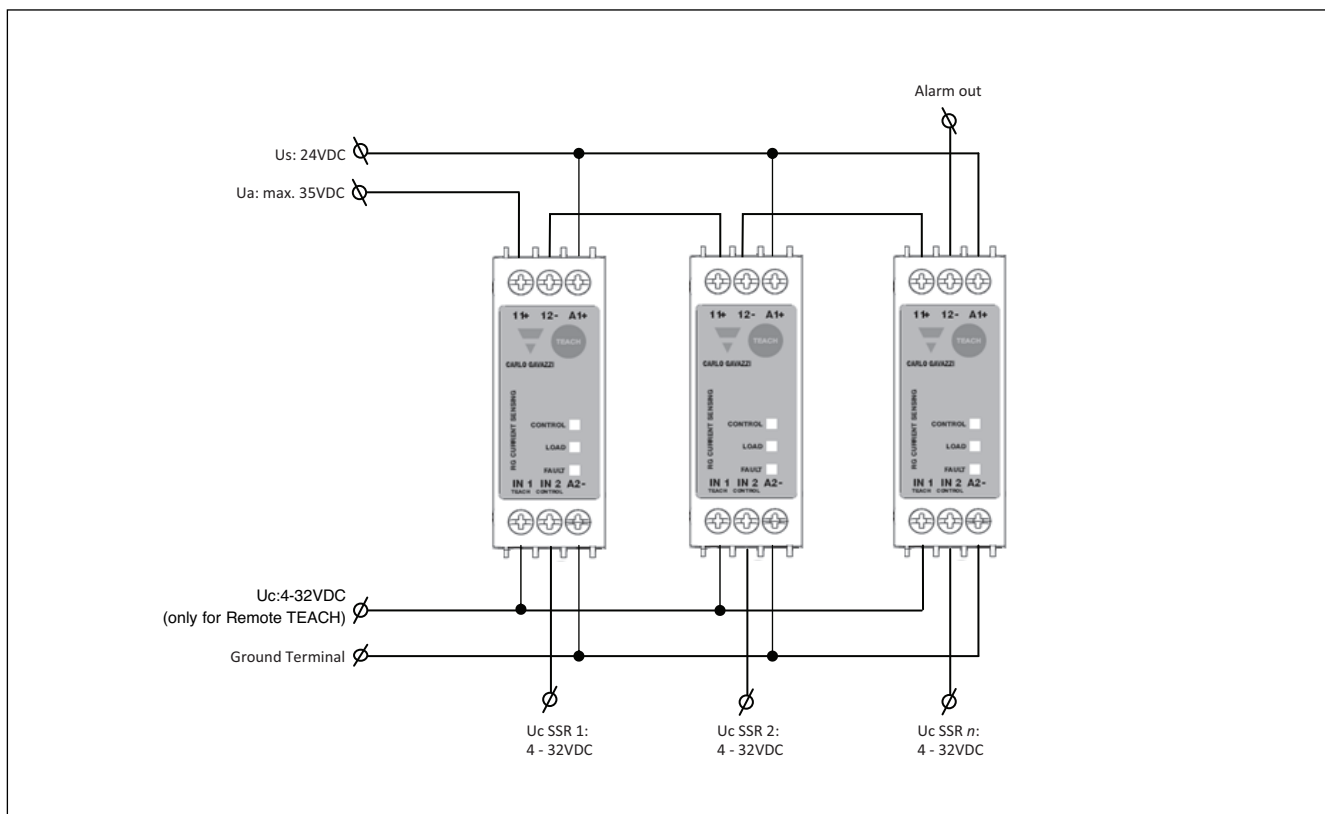

## Connection Diagram for Separate Alarm Outputs



## Connection Diagram for Series Alarm Outputs



## Alarm LED Indications (Red LED)

Flashes	Description of Fault	Timing Diagram
1	Locked TEACH	
2	Open SSR / Heater	
3	SSR Overtemperature	
4	SSR Short Circuit	
50%	No TEACH setpoint	
100%	Partial Load Failure	

## Mode of Operation

### Introduction:

The RG.1S must have a stored current setpoint to operate as a Solid State Relay with a Sensing function. The current setpoint is the nominal operating current that is expected through the SSR when all heater loads are functioning properly. The SSR is shipped without having a stored setpoint. This current setpoint is to be stored upon a TEACH procedure as explained below. The wrong setpoint is stored if heater loads are faulty or mains supply voltage is not close to operating voltage during the TEACH procedure.

### SSR Operation without the TEACH procedure

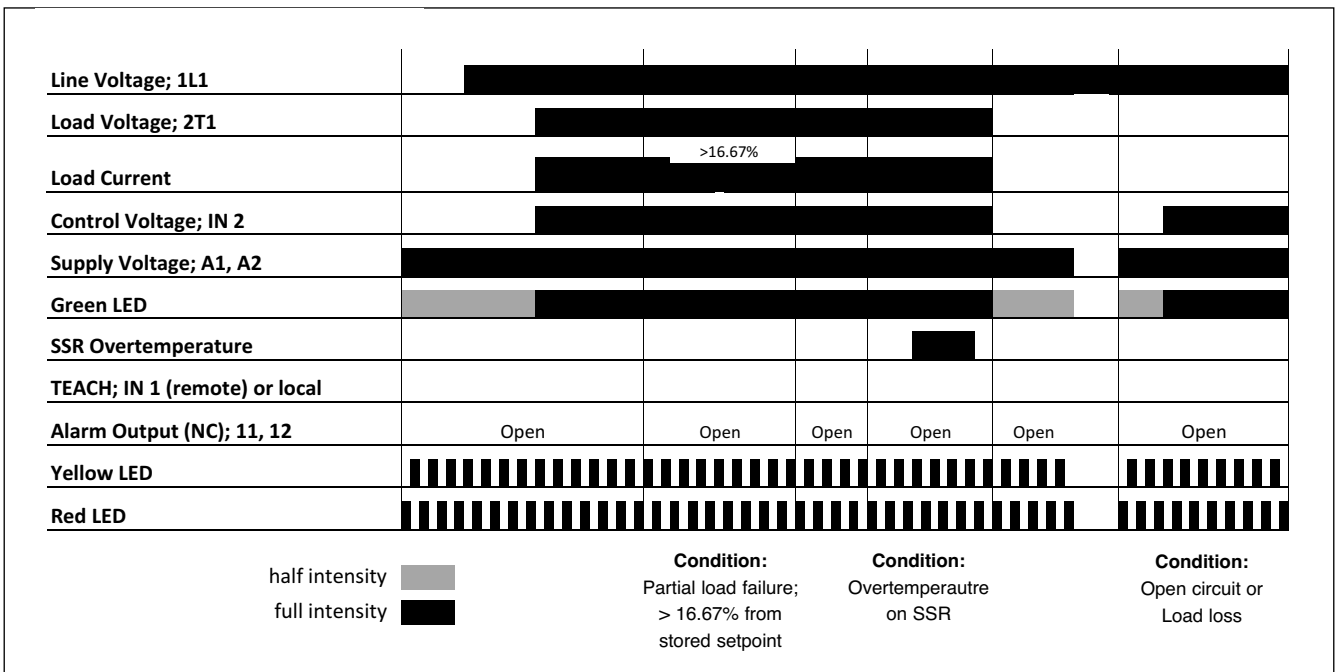

Upon application of supply voltage, the yellow and red LED will flash continuously in sequence (i.e., scroll) indicating that the device has no current setpoint stored. The green LED is ON at half intensity indicating the presence of supply voltage. As soon as control voltage is applied the green LED will be ON at full intensity. The alarm output, which is normally closed, is open to indicate that the SSR has no stored setpoint.

If mains supply is present upon application of control voltage the SSR will switch ON despite having no stored current setpoint. However, even though the SSR switches ON, the Sensing features associated with the RG.1S are disabled as shown in the above operations diagram. The Sensing features will be enabled ONLY once the TEACH procedure explained below is completed.

For SSR to switch ON upon application of control voltage, supply voltage has to be present across terminals A1, A2.

## Mode of Operation (cont.)

### The TEACH procedure

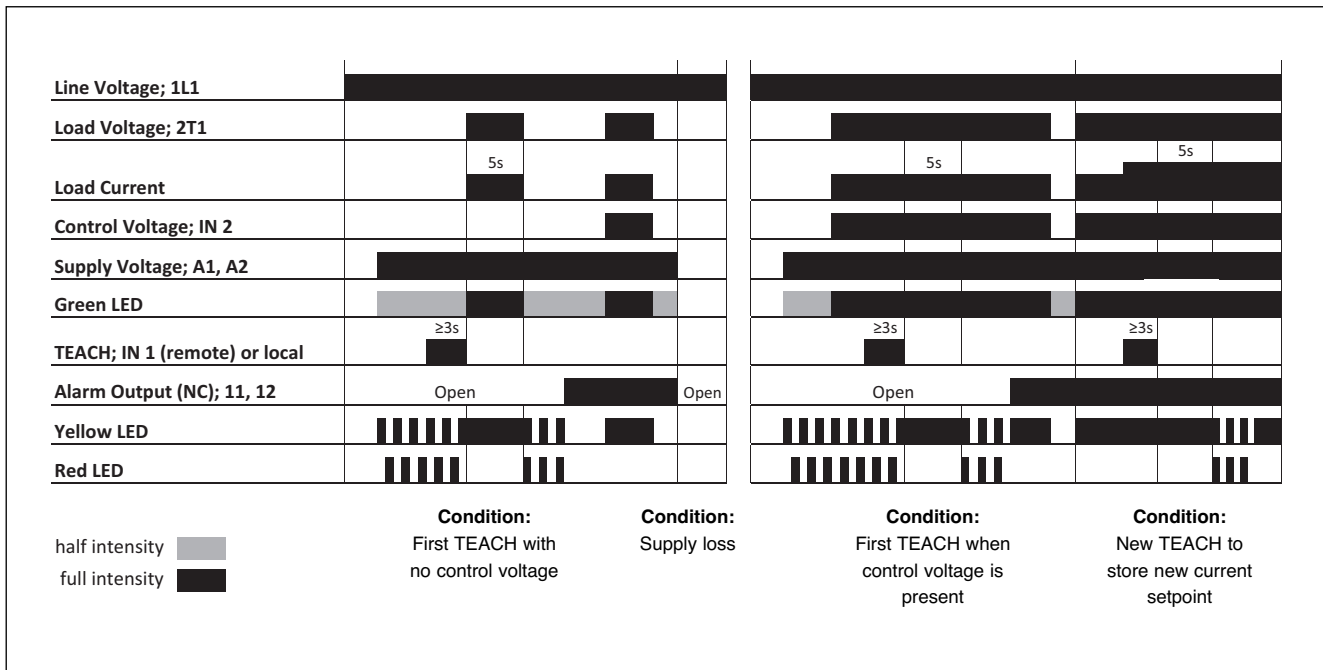

The TEACH procedure can be performed either locally or remotely. For local TEACH, the front 'TEACH' button on the SSR has to be pressed for at least 3 seconds (but less than 5 seconds). Remote TEACH can be performed by applying a high signal on terminal IN 1 for a duration of at least 3 seconds (but less than 5 seconds).

Supply voltage has to be present across terminals A1, A2 for the TEACH function to be performed and SSR to operate.

#### TEACH in the absence of a control signal

It is possible to TEACH the SSR without the presence of a control signal. In case of no previous stored setpoint (factory default), red and yellow LED will flash accordingly indicating this. The TEACH function will start as soon as the push button is released. The SSR will switch fully ON for 5 seconds (yellow LED ON during these 5 seconds) at the end of which, a load current setpoint is recorded. If TEACH procedure is successful the yellow and red LED will blink together for three times to indicate a successful setpoint measurement. The alarm output across terminals 11, 12 closes indicating a normal situation.

In case of an unsuccessful TEACH, the red & yellow LED will scroll continuously indicating that no current setpoint is stored. If load current does not stabilise during the 5 seconds TEACH sequence, it will not be possible to store setpoint. Another attempt to do a TEACH may be done until setpoint is recorded.

#### TEACH when control signal is present

In this case the TEACH procedure is identical to the TEACH procedure when there is no control signal. During the 5 seconds TEACH the status of the load switching will not be distinguished from unTEACHed state since load was ON before TEACH. Load remains ON as long as control voltage is present.

If SSR is in a LOCKed position (see below) it will not be possible to perform a new TEACH. SSR has to be unLOCKed first.

## Mode of Operation (cont.)

### Fault Conditions

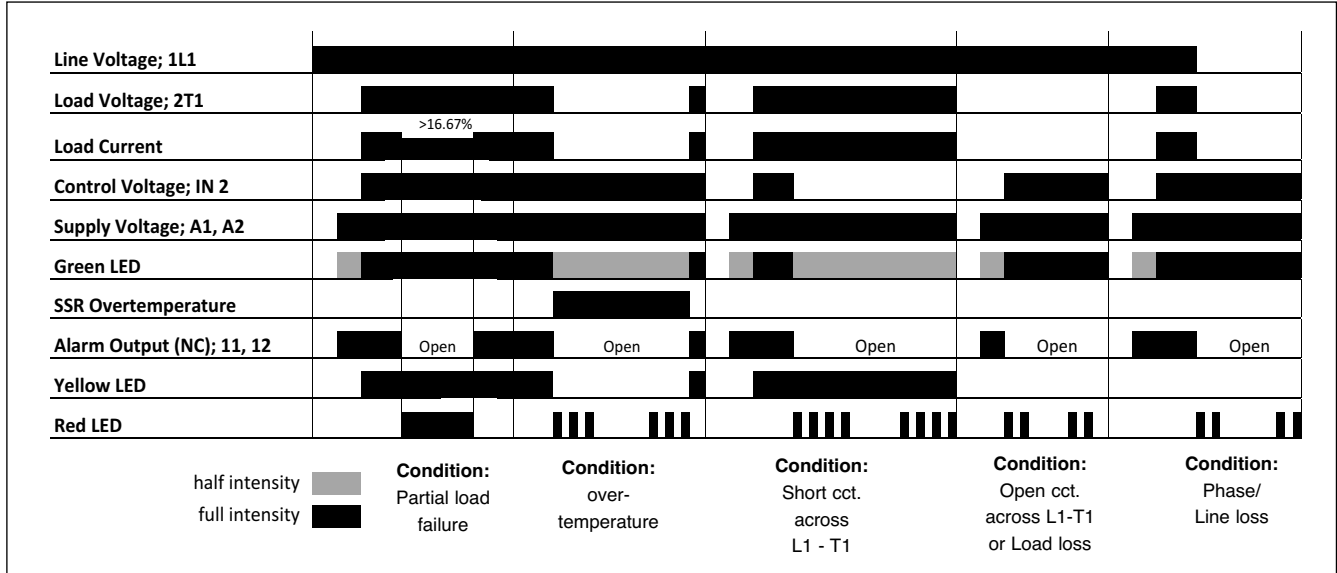

#### Partial Load Failure

This occurs when the load current decreases by more than 16.67% as compared to the stored setpoint. During this failure mode the SSR remains ON but alarm output opens to indicate an alarm condition. The red LED is continuously ON during this condition. If current rises back to normal levels the alarm indications switch to the normal state.

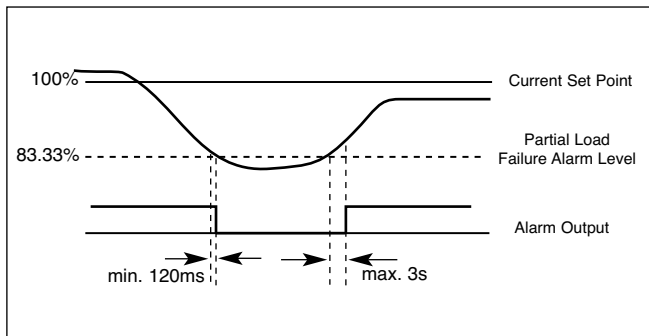

#### Over Temperature

If the SSR derating curve is exceeded during normal operation, an over-temperature condition is detected and the SSR output switches OFF. A visual alarm is indicated by the red blinking LED (3 flashes - see details in ALARM LED INDICATIONS) and alarm signal opens. The alarm resets automatically when the overtemperature condition is no longer present.

#### SSR Short Circuit

This condition is detected in the absence of a control signal and load current (in the region of 800mA and over) still flowing through the SSR. A visual indication is given by the red blinking LED (4 flashes - see details in ALARM LED INDICATIONS) and open alarm across terminals 11, 12. The yellow LED stays ON even though the green LED is at half intensity (i.e. absence of control input voltage) to indicate status of load.

#### SSR Open Circuit / Heater Loss / Line Loss

SSR output remains OFF even after application of the control voltage on terminal IN 2. A visual indication is given by the red blinking LED (2 flashes - see details in ALARM LED INDICATIONS) and open alarm across terminals 11, 12.

#### Alarm auto reset

In all alarm conditions described above, the alarm LED and signal output from terminals 11, 12 reset automatically to the normal condition as soon as the alarm condition is no longer present. There is no need for an alarm reset.

#### Other functions: TEACH LOCK/UNLOCK

The device can be locked to prevent undesirable local TEACH. This can be done by sending a pulse with a duration between 1s and 1.5s to the remote TEACH terminal IN 1. To TEACH a LOCKed unit, a pulse with duration between 1s and 1.5s has to be applied first to terminal IN 1, before performing the TEACH. The initial condition of the unit after every power up (through A1, A2 terminals) is UNLOCKed.



## Agency Approvals and Conformances

<b>Conformance &amp; Approvals</b>	<b>RGC1S..</b> EN/IEC 60947-4-3 EN/IEC 62314 UL508 Listed (E172877) cUL Listed (E172877)	<b>Conformance &amp; Approvals</b>	<b>RGS1S..</b> EN/IEC 60947-4-3 EN/IEC 62314 UL 508 Recognised (E172877) CSA 22.2 No. 14-10 (204075)
<b>Short Circuit Current Rating</b>	100kA, UL508	<b>Short Circuit Current Rating</b>	100kA, UL508



## Electromagnetic Compatibility

<b>EMC Immunity</b>	IEC/EN 61000-6-2	10V/m, 80 - 1000 MHz	Performance Criteria 1
<b>Electrostatic Discharge (ESD) Immunity</b>	IEC/EN 61000-4-2	10V/m, 1.4 - 2 GHz	Performance Criteria 1
Air discharge, 8kV	Performance Criteria 1	3V/m, 2 - 2.7 GHz	Performance Criteria 1
Contact, 4kV	Performance Criteria 1	<b>Conducted Radio Frequency Immunity</b>	IEC/EN 61000-4-6
<b>Electrical Fast Transient (Burst) Immunity</b>	IEC/EN 61000-4-4	10V/m, 0.15 - 80 MHz	Performance Criteria 1
Output: 2kV, 5kHz	Performance Criteria 1	<b>Voltage Dips Immunity</b>	IEC/EN 61000-4-11
Input: 1kV, 5kHz	Performance Criteria 1	0% for 10ms/20ms,	Performance Criteria 2
<b>Electrical Surge Immunity</b>	IEC/EN 61000-4-5	40% for 200ms	Performance Criteria 2
Output, line to line, 1kV	Performance Criteria 1	70% for 500ms	Performance Criteria 2
Output, line to earth, 2kV	Performance Criteria 1	<b>Voltage Interruptions Immunity</b>	IEC/EN 61000-4-11
DC lines, line to line, 500V	Performance Criteria 2	0% for 5000ms	Performance Criteria 2
DC lines, line to earth, 500V	Performance Criteria 2		
Signal lines, line to earth, 1kV	Performance Criteria 2		
<b>Radiated Radio Frequency Immunity</b>	IEC/EN 61000-4-3		
<b>EMC Emission</b>	IEC/EN 61000-6-4	<b>Radio Interference Field Emission (Radiated)</b>	IEC/EN 55011
<b>Radio Interference Voltage Emission (Conducted)</b>	IEC/EN 55011	<b>30 - 1000MHz</b>	Class A (industrial)
<b>0.15 - 30MHz</b>	Class A (industrial) with filters - see filter information		
	IEC/EN 60947-4-2,		
	IEC/EN60947-4-3		
	Class A (no filtering needed)		

Note:

- Control input lines must be installed together to maintain products' susceptibility to Radio Frequency interference.
- Use of AC solid state relays may, according to the application and the load current, cause conducted radio interferences. Use of mains filters may be necessary for cases where the user must meet E.M.C requirements. The capacitor values given inside the filtering specification tables should be taken only as indications, the filter attenuation will depend on the final application.
- Performance Criteria 1: No degradation of performance or loss of function is allowed when the product is operated as intended.
- Performance Criteria 2: During the test, degradation of performance or partial loss of function is allowed. However when the test is complete the product should return operating as intended by itself.
- Performance Criteria 3: Temporary loss of function is allowed, provided the function can be restored by manual operation of the controls.

## Filtering - EN / IEC 55011 Class A compliance (for class B compliance contact us)

Part Number	Suggested filter for compliance	Maximum Heater current
RG.1S60D20GKEP	100 nF / 760V / X1	20 AAC
RGC1S60D25GKEP	220nF / 760V / X1	25 AAC
RG.1S60D30GKEP	220 nF / 760V / X1	30 AAC
RG.1S60D31GKEP	220 nF / 760V / X1	30 AAC
RGC1S60D41GG.P	330 nF / 760V / X1	40 AAC
RG.1S60D61GG.P	470 nF / 760V / X1	65 AAC
RGC1S60D90GGEP	470 nF / 760V / X1	65 AAC

## Filter Connection Diagrams

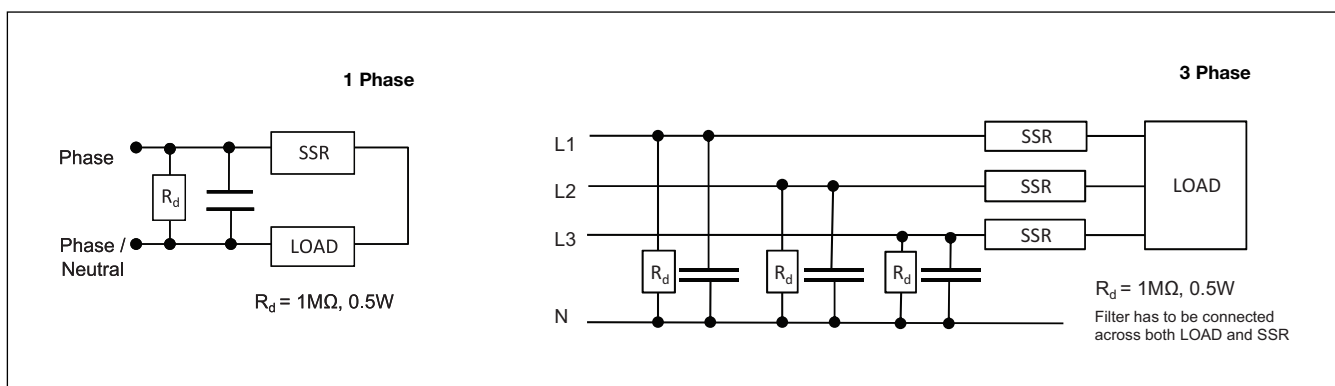

## Environmental Specifications









Operating Temperature	-25°C to 70°C (-13°F to +158°F)	Relative humidity	95% non-condensing @ 40°C
Storage Temperature	-40°C to 100°C (-40°F to +212°F)	UL flammability rating (housing)	UL 94 V0
RoHS (2002/95/EC)	Compliant	Installation altitude	0-1000m. Above 1000m derate linearly by 1% of FLC per 100m up to a maximum of 2000m
Impact resistance (EN50155, EN61373)	15/11 g/ms		
Vibration resistance (2-100Hz, IEC60068-2-26, EN50155, EN61373)	2g per axis		

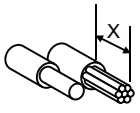

## Connection Specifications

### POWER CONNECTIONS: 1/L1, 2/T1

Use 75°C copper (Cu) conductors

	RG..20, 25, 30, 31GKEP	RG..41GG.P; RG..61GG.P; RG..90GGEP
<b>Stripping Length (X)</b>	12mm	11mm
<b>Connection type</b>	M4 screw with captivated washer	M5 screw with box clamp
<b>Rigid (Solid &amp; Stranded)</b> UL/ cUL rated data	  2 x 2.5..6 mm <sup>2</sup> 2 x 14.. 10 AWG	 1 x 2.5..6 mm <sup>2</sup> 1 x 14.. 10 AWG
<b>Flexible with end sleeve</b>	 2 x 1.0 ... 2.5mm <sup>2</sup> 2 x 2.5..4mm <sup>2</sup> 2 x 18.. 14 AWG 2 x 14.. 12 AWG	 1 x 2.5..6mm <sup>2</sup> 1 x 14.. 10 AWG
<b>Flexible without end sleeve</b>	 2 x 1.0 ... 2.5mm <sup>2</sup> 2 x 2.5.. 6mm <sup>2</sup> 2 x 18.. 14 AWG 2 x 14.. 10 AWG	 1 x 2.5..16mm <sup>2</sup> 1 x 14.. 6 AWG
<b>Torque specifications</b>	 Pozidriv 2 UL : 2Nm (17.7lb-in.) IEC: 1.5 - 2.0Nm (13.3 - 17.7lb-in)	Pozidriv 2 UL : 2.5Nm (22lb-in.) IEC: 2.0 - 2.5Nm (17.7 - 22lb-in)
<b>Aperture for termination lug</b>	12.3mm	N/A

### Protective Earth Connection



M5, 1.5Nm (13.3 in-lb)

Note: M5 PE screw not provided with SSR. PE connection required when product is intended to be used in Class 1 applications according to EN/IEC 61140.

### CONTROL CONNECTIONS:

Use 60/75°C copper (Cu) conductors

### A1(+), A2(-), IN1, IN2, 11 (+), 12(-)

#### Torque specifications



M3, Pozidriv 1  
 UL: 0.5Nm (4.4lb-in)  
 IEC: 0.4 - 0.5Nm (3.5 - 4.4lb-in)

#### Stripping Length (X)

6mm

13mm

#### Rigid (Solid & Stranded)

UL/ cUL rated data

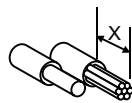

2 x 1.0..2.5mm<sup>2</sup>  
 2 x 18..14 AWG



1 x 1.0..2.5mm<sup>2</sup>  
 1 x 18..14 AWG

#### Flexible with end sleeve



2 x 1.0..2.5mm<sup>2</sup>  
 2 x 18..14AWG

1 x 1.0..2.5mm<sup>2</sup>  
 1 x 18..14AWG

## Dimensions: RGS1S

RGS1S60D20GKEP, RGS1S60D30GKEP, RGS1S60D31GKEP

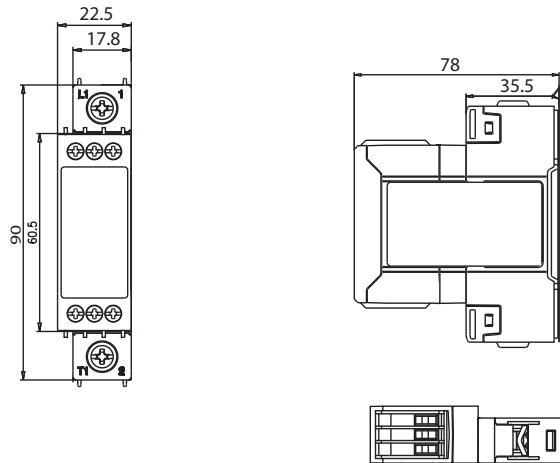

RGS1S60D61GGEP

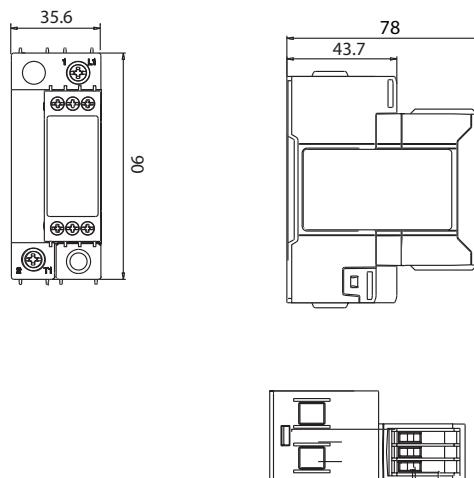

RGS1S60D61GGUP

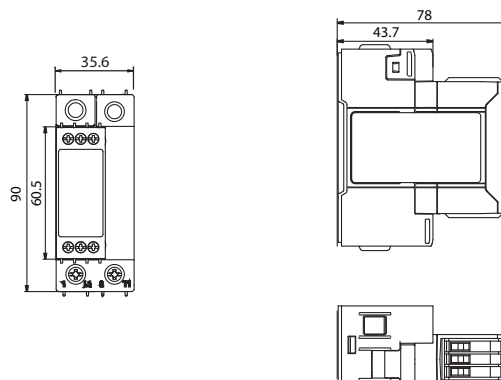

Housing width tolerance +0.5mm, -0mm...as per DIN43880  
 All other tolerances:  $\pm 0.5\text{mm}$   
 All dimensions in mm

## Dimensions: RGC1S

RGC1S60D20GKEP

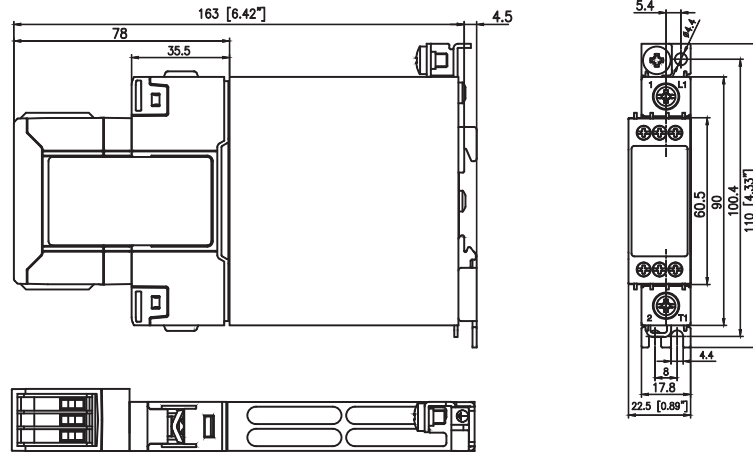

RGC1S60D25GKEP

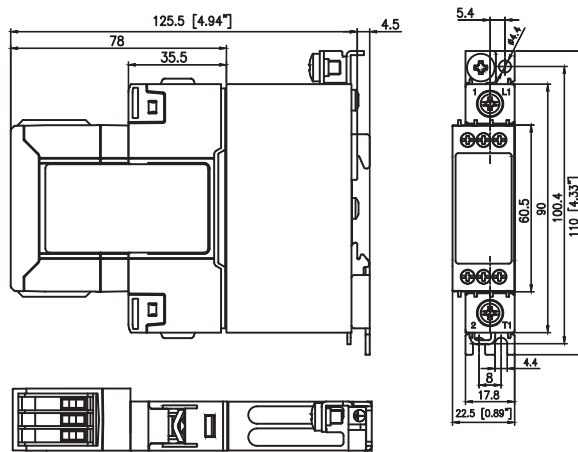

RGC1S60D30GKEP , RGC1S60D31GKEP

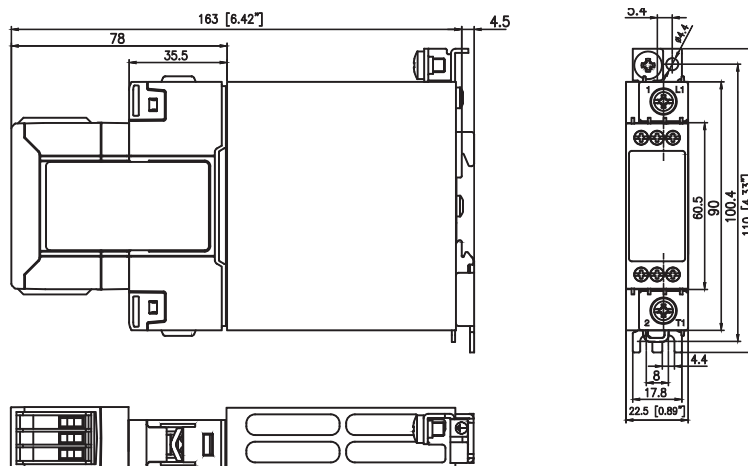

Housing width tolerance +0.5mm, -0mm...as per DIN43880  
 All other tolerances:  $\pm 0.5\text{mm}$   
 All dimensions in mm

## Dimensions: RGC1S

RGC1S60D41GGEP

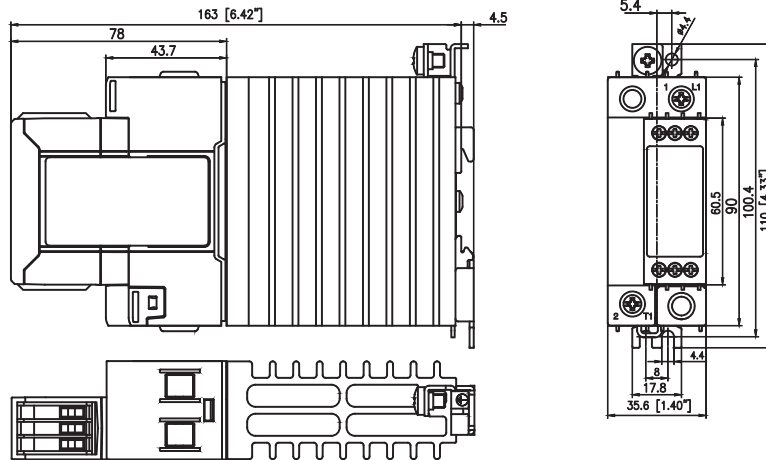

RGC1S60D61GGEP

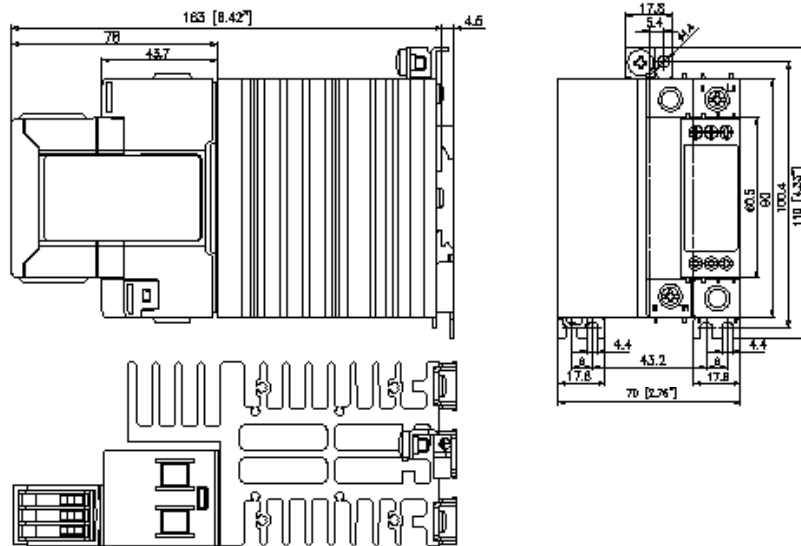

RGC1S60D90GGEP

(fan to be supplied externally - no terminations provided on the RG module)

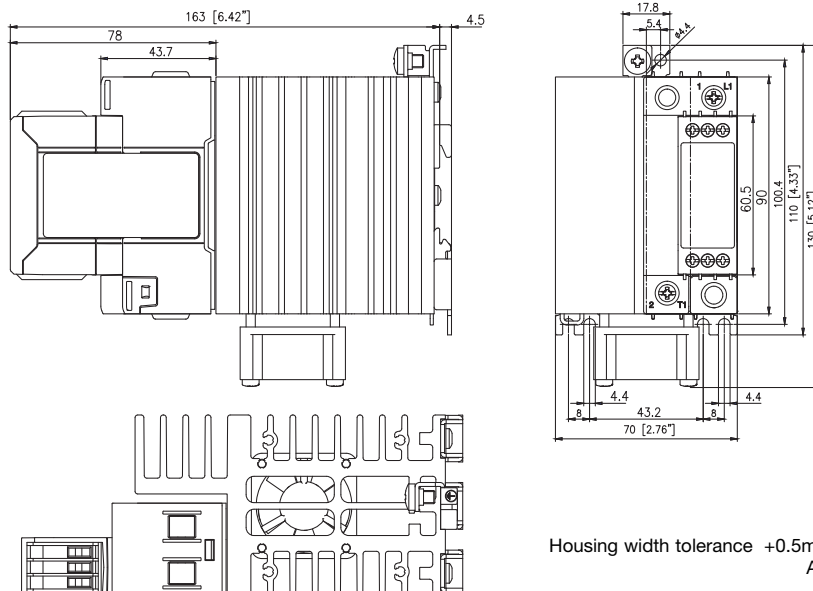

Housing width tolerance +0.5mm, -0mm...as per DIN43880  
 All other tolerances: ± 0.5mm  
 All dimensions in mm

## Dimensions: RGC1S

RGC1S60D41GGUP

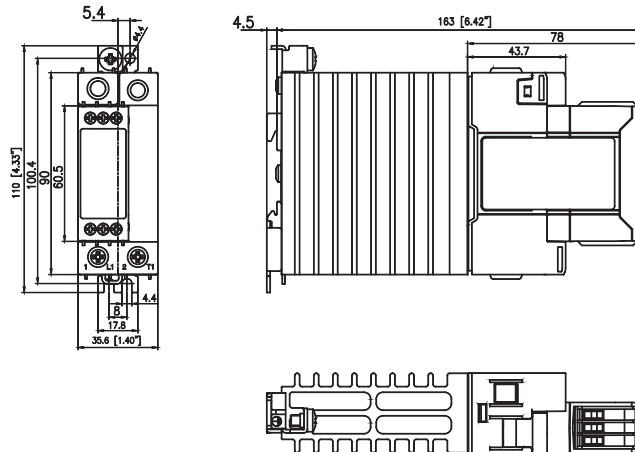

RGC1S60D61GGUP

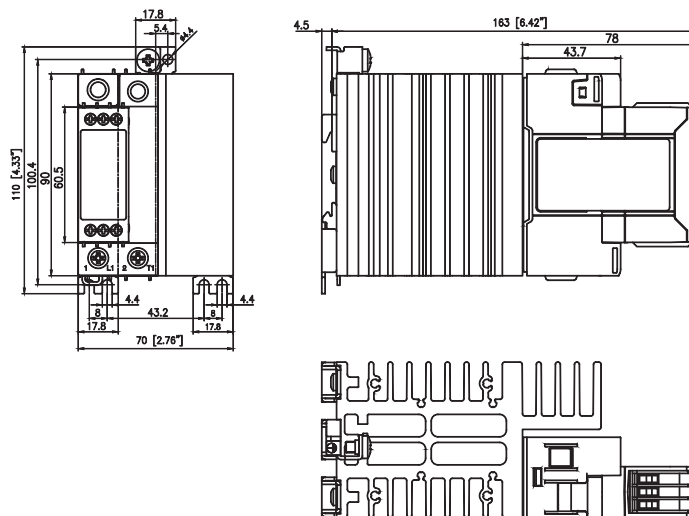

Housing width tolerance +0.5mm, -0mm...as per DIN43880  
 All other tolerances:  $\pm 0.5$ mm  
 All dimensions in mm

## Installation Instructions

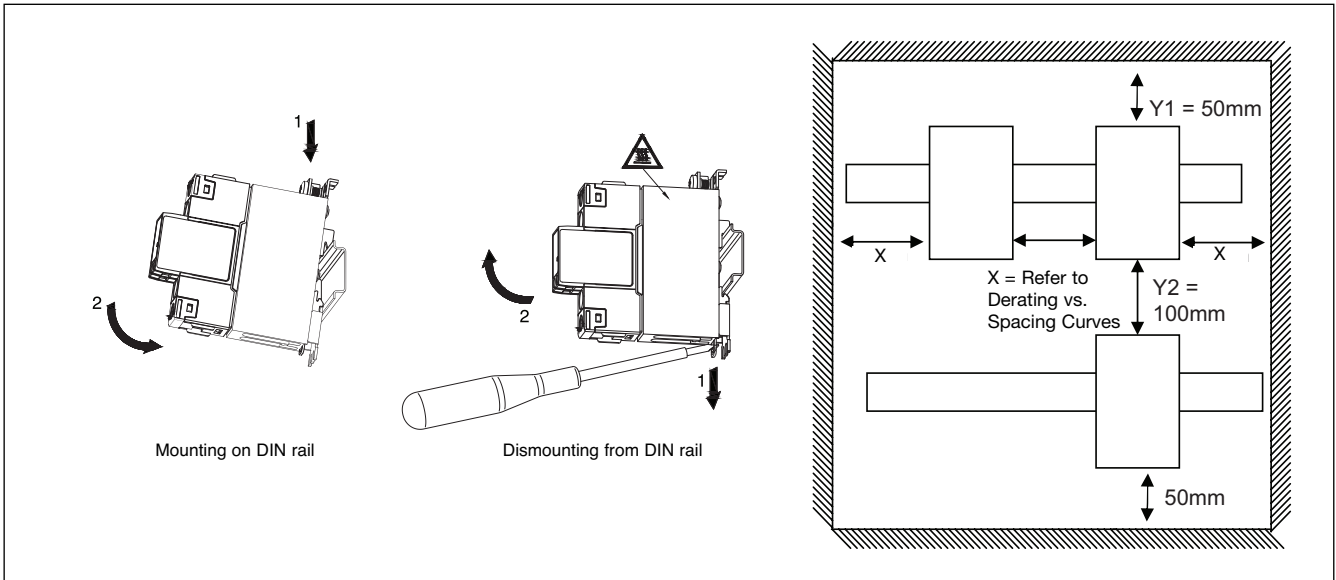

## Mounting Instructions for RGS1S

Thermal stress will reduce the lifetime of the SSR. Therefore it is necessary to select the appropriate heatsinks, taking into account the surrounding temperature, load current and the duty cycle.

A small amount of thermally conductive silicone paste must be applied to the back of the SSR. The RG Power Module should be first mounted on the heatsink with two M5 screws. Gradually tighten each screw (alternating between the two) until both are tightened with a torque of 0.75Nm. Then tighten both screws to their final mounting torque of 1.5Nm.

In case of a thermal pad attached to the back of the SSR, no thermal paste is required. The RG Power Module is gradually tightened (alternating between the 2 screws) to a maximum torque of 1.5Nm.

Once the power module is tightened to heatsink, the control module can be mounted on top of the power module and screwed with a torque of 0.3Nm to ensure good contact between the 2 units.

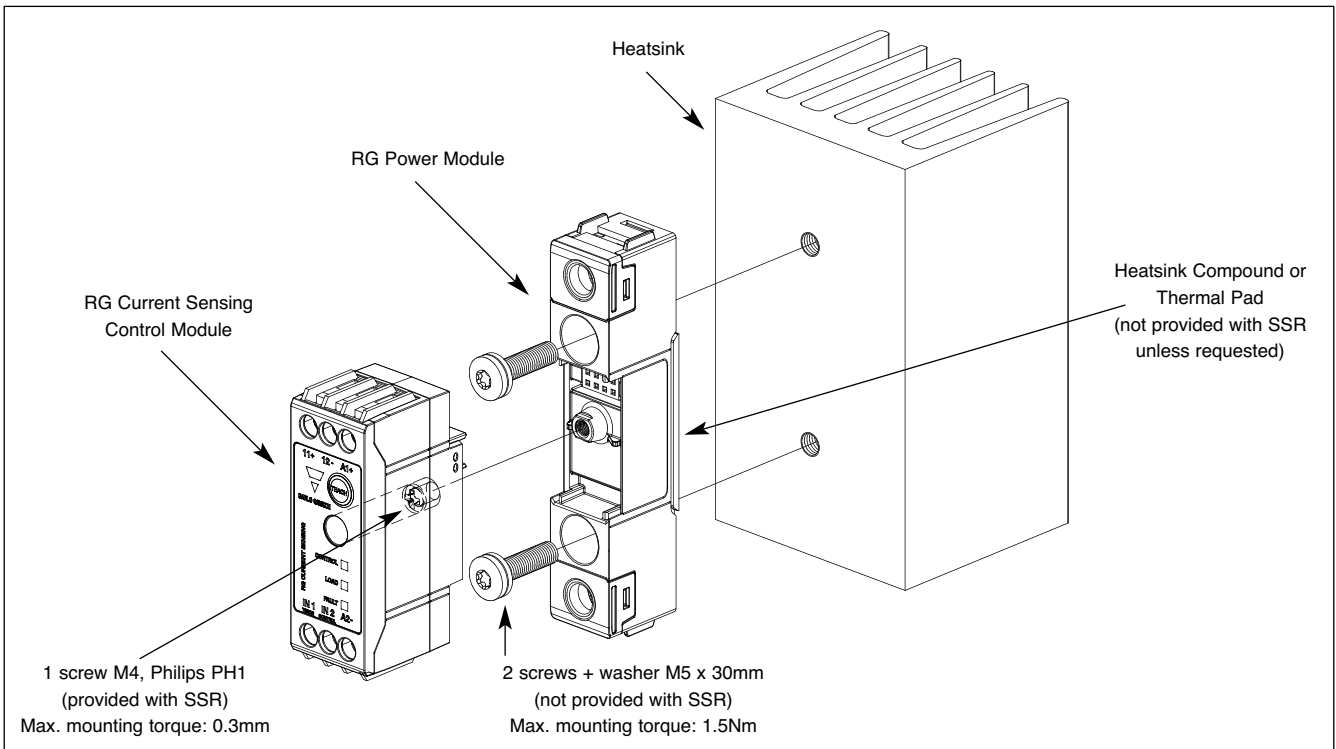

## Short Circuit Protection

### Protection Co-ordination, Type 1 vs Type 2:

Type 1 protection implies that after a short circuit, the device under test will no longer be in a functioning state. In type 2 co-ordination the device under test will still be functional after the short circuit. In both cases, however the short circuit has to be interrupted. The fuse between enclosure and supply shall not open. The door or cover of the enclosure shall not be blown open. There shall be no damage to conductors or terminals and the conductors shall not separate from terminals. There shall be no breakage or cracking of insulating bases to the extent that the integrity of the mounting of live parts is impaired. Discharge of parts or any risk of fire shall not occur.

The product variants listed in the table hereunder are suitable for use on a circuit capable of delivering not more than 100,000A rms Symmetrical Amperes, 600 Volts maximum when protected by fuses. Tests at 100,000A were performed with Class J fuses, fast acting; please refer to the table below for maximum allowed ampere rating of the fuse. Use fuses only.

Class CC fuses are represented by tests performed on Class J fuses.

### Co-ordination type 1 (UL508)

Part No.	Max. fuse size [A]	Class	Current [kA]	Voltage [VAC]
RG.1S60D20GKEP	30	J or CC	100	Max. 600
RGC1S60D25GKEP	30	J or CC	100	Max. 600
RG.1S60D30GKEP	30	J or CC	100	Max. 600
RG.1S60D31GKEP	40	J	100	Max. 600
RGC1S60D41GG.P	40	J	100	Max. 600
RG.1S60D61GG.P	40	J	100	Max. 600
RGC1S60D90GGEP	40	J	100	Max. 600

### Co-ordination type 2 (IEC EN 60947-4-2/ -4-3)

Part No.	Ferraz Shawmut		Siba		Current [kA]	Voltage [VAC]
	Max fuse size [A]	Part number	Max fuse size [A]	Part number		
RG.1S60D20GKEP	32	6.9xx CP URD 22x58/32 (xx = 00 or 21)	32	50 142 06.32	100	Max. 600
RGC1S60D25GKEP	40	A70QS40-4	32	50 142 06.32	100	Max. 600
RG.1S60D30GKEP	40	A70QS40-4	32	50 142 06.32	100	Max. 600
RG.1S60D31GKEP	40	A70QS40-4	40	50 194 20.40	100	Max. 600
RGC1S60D41GG.P	60	A70QS60-4	63	50 194 20.63	100	Max. 600
RG.1S60D61GG.P	90	A70QS90-4	100	50 194 20.100	100	Max. 600
RGC1S60D90GGEP	100	A70QS100-4	100	50 194 20.100	100	Max. 600

## Type 2 Protection with Miniature Circuit Breakers (M. C. B.s)

Solid State Relay type	ABB Model no. for Z - type M. C. B. (rated current)	ABB Model no. for B - type M. C. B. (rated current)	Wire cross sectional area [mm <sup>2</sup> ]	Minimum length of Cu wire conductor [m] <sup>9</sup>	
<b>RG..20</b>	<b>1 pole</b>				
	S201 - Z4 (4A)	S201 - B2 (2A)	1.0	21.0	
	S201 - Z6 UC (6A)	S201 - B2 (2A)	1.0 1.5	21.0 31.5	
<b>RG..25</b> <b>RG..30</b>	<b>1 pole</b>				
	S201 - Z10 (10A)	S201-B4 (4A)	1.0	7.6	
			1.5	11.4	
			2.5	19.0	
	S201 - Z16 (16A)	S201-B6 (6A)	1.0	5.2	
			1.5	7.8	
			2.5	13.0	
			4.0	20.8	
	S201 - Z20 (20A)	S201-B10 (10A)	1.5	12.6	
			2.5	21.0	
	S201 - Z25 (25A)	S201-B13 (13A)	2.5	25.0	
			4.0	40.0	
	<b>2 pole</b>				
	S202 - Z25 (25A)	S202-B13 (13A)	2.5 4.0	19.0 30.4	
	<b>RG ... 31, 41, 61, 90</b>	<b>1 pole</b>			
S201 - Z20 (20A)		S201-B10 (10A)	1.5	4.2	
			2.5	7.0	
			4.0	11.2	
S201 - Z32 (32A)		S201-B16 (16A)	2.5	13.0	
			4.0	20.8	
			6.0	31.2	
<b>2 pole</b>					
S202 - Z20 (20A)		S202-B10 (10A)	1.5	1.8	
			2.5	3.0	
			4.0	4.8	
S202 - Z32 (32A)		S202-B16 (16A)	2.5	5.0	
			4.0	8.0	
			6.0	12.0	
			10.0	20.0	
S202 - Z50 (50A)	S202-B25 (25A)	4.0	14.8		
		6.0	22.2		
		10.0	37.0		

9. Between MCB and Load (including return path which goes back to the mains).

Note: A prospective current of 6kA and a 230/400V power supply system is assumed for the above suggested specifications. For cables with different cross section than those mentioned above please consult Carlo Gavazzi's Technical Support Group.



## Accessories

### RG DIN Clip



### Ordering Key

DIN clip accessory

**RGS1DIN**

This DIN Clip accessory can be mounted to any RGS model and will enable the RGS to be DIN rail mount. Current rating @ 40°C is 10AAC. Refer to 'Current Derating' section for Space Derating.

### Mounting Instructions for RGS1DIN to RGS

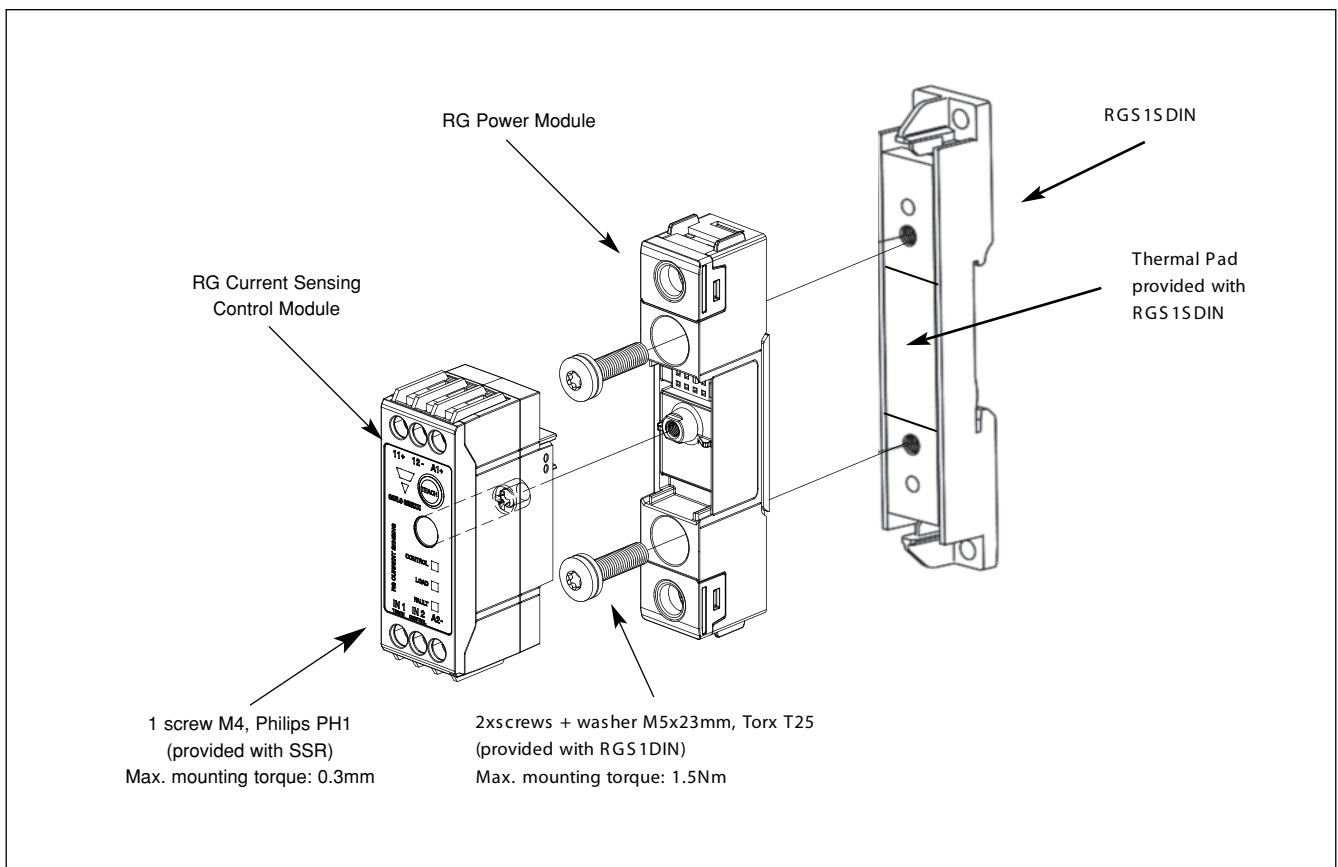

The RG Power Module is gradually tightened (alternating between the 2 screws) to a maximum torque of 1.5Nm.

Once the power module is tightened to the RGS1DIN, the control module can be mounted on top of the power module and screwed with a torque of 0.3Nm to ensure good contact between the 2 units.

**Accessories (cont.)**

**RGS1DIN Dimensions**

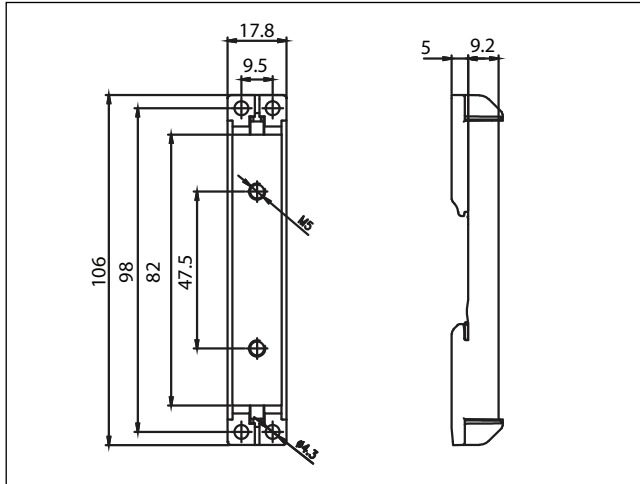

**Installation Instructions**

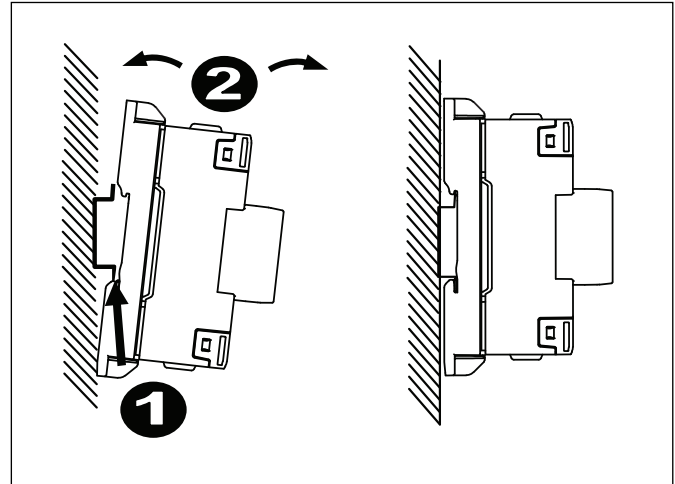

**Current Derating (RGS1S + RGS1DIN)**

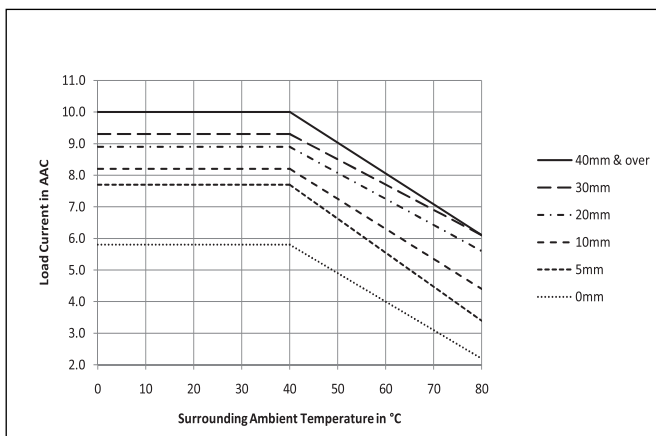

## Accessories (cont.)

### Heatsink RHS37A

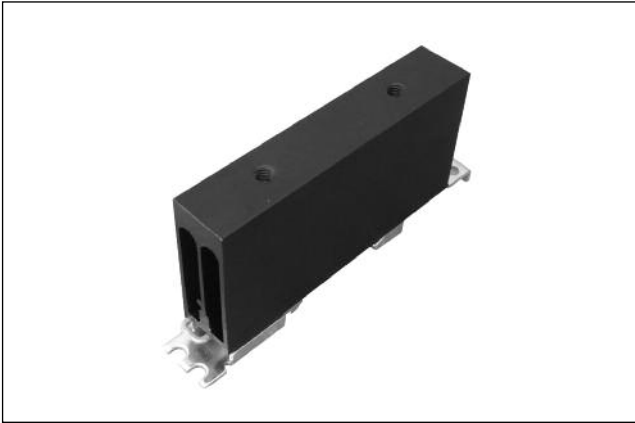

### Ordering Key

Heatsink with DIN rail clip

**RHS37A**

Factory mounted heatsink to RGS

**RGS...H51**

RGS1S60D20GKEP + RHS37A = RGS1S60D20GKEPH51

RGS1S60D31GKEP + RHS37A = RGS1S60D31GKEPH51

### Dimensions

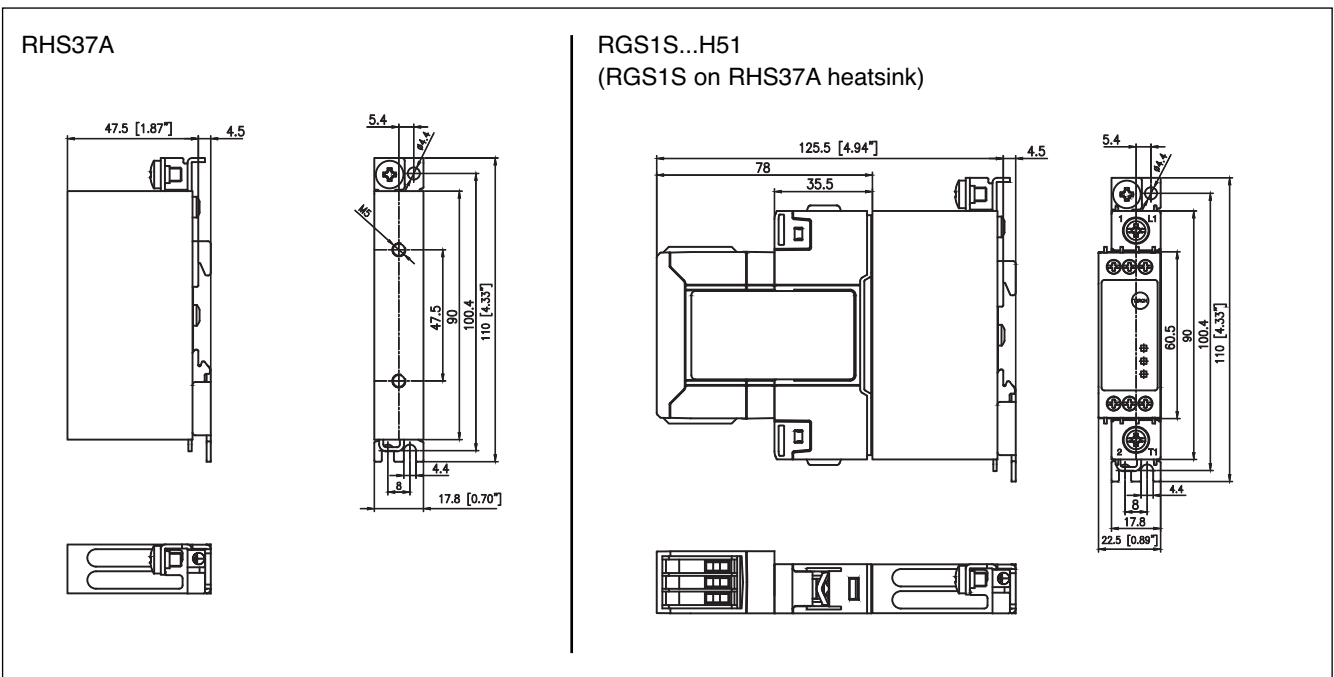

All dimensions in mm

**Accessories (cont.)**

**Derating Curves (RGS1S assembled to heatsink RHS37A)**

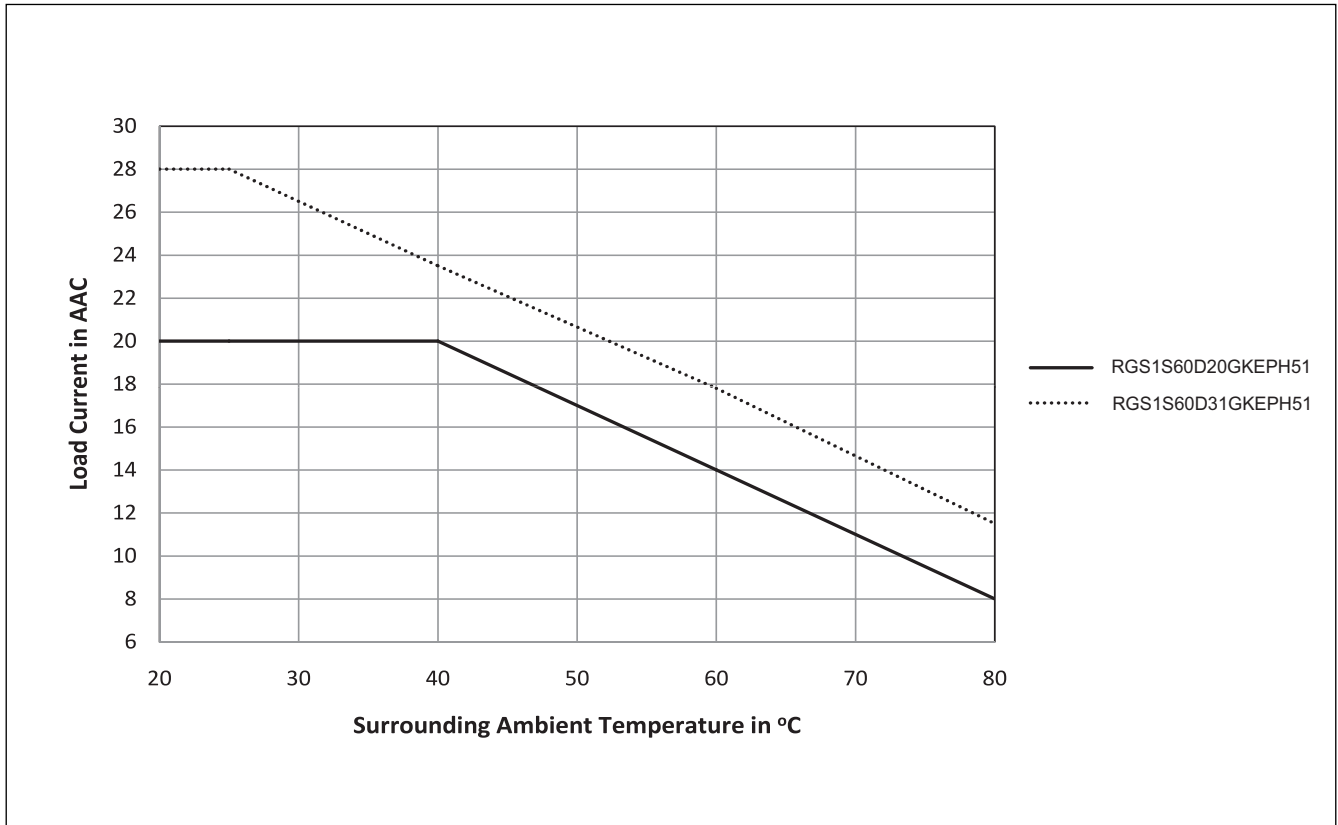

**RHS37A Thermal Resistance Curve**

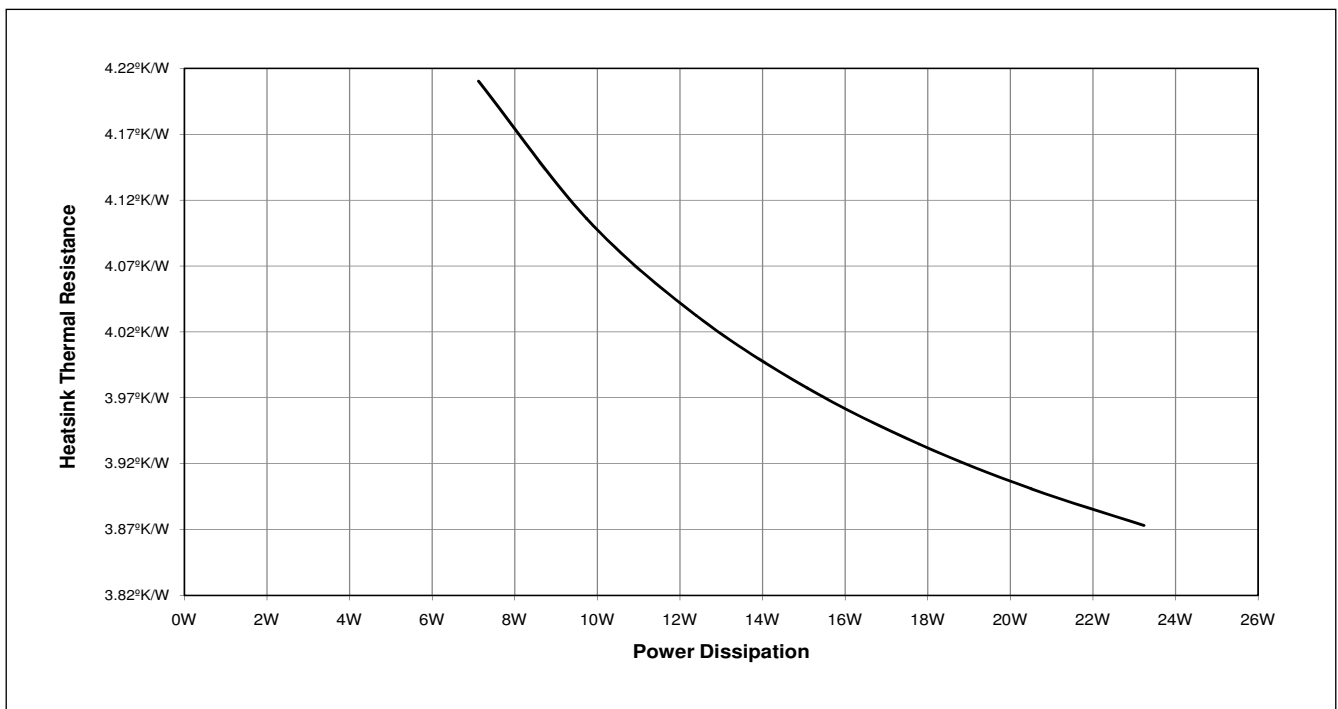

## Accessories (cont.)

---

### Thermal Pads



#### Ordering Key

Thermal pad  
mounted on RGS

**RGS...HT**

Pack of 10 thermal pads  
size 34.6 x 14mm

**RGHT**