

Motor Controllers

AC Semiconductor Motor Controller

Type RSHR 3-Phase



- Soft starting and stopping of 3-phase squirrel cage motors
- Control of all 3 phases
- In Line or In Delta motor connection
- Low inrush and reduced vibration during starting
- External power supply option for a wide operational voltage range
- Rated operational voltage: up to 600 VAC, 50/60 Hz
- Rated operational current: up to 32A AC-53a
- LED status indicators
- Motor PTC protection
- Device over-temperature protection
- DIN rail mounting*

* Accessory for panel mounting available

Product Description

Compact, digital AC semiconductor motor controller. When used on a typical 400VAC supply, this controller can soft-start and soft-stop 3-phase motors up to 22kW (30HP) when connected In Delta and up to 15kW (20HP) when connected In Line. All 3-phases are switched. Starting and stopping time as well as initial torque can be

independently adjusted by potentiometers on the fascia. A version adapted for starting Scroll Compressors is also available.

This device does not include internal bypass relays but provides a relay contact to help energise an external bypass contactor.

Ordering Key

RSHR 48 32 C V33

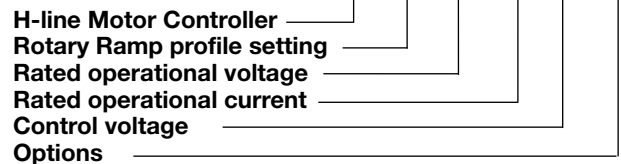

Type Selection

Type	Rated Operational Voltage Ue	Rated operational Current Ie	Control Voltage Uc	Options
RSHR:	22: 127/220VACrms, 50/60Hz	25: 25A AC-53a	C: 24 - 550VAC/DC	V32: In Line
H-line motor	40: 230/400VACrms, 50/60Hz	32: 32A AC-53a	D: 24 - 660VAC/DC	V33: In Delta
controller with	48: 277/480VACrms, 50/60Hz			V34: In Line with external supply
rotary settings	60: 346/600VACrms, 50/60Hz			V35: In Delta with external supply
	M: 220-480VACrms, 50/60Hz*			V38: In Line, Scroll Compressors
	400-480VACrms, 50/60Hz*			

* requires external supply

Selection Guide

Rated operational voltage Ue	Control Voltage Uc	Supply Voltage Us	Connection	Rated operational current Ie @ 40°C	
				25A AC-53a	32A AC-53a
220VACrms	24-550VAC/DC	-	In Line	RSHR2225CV32	RSHR2232CV32
			In Delta	RSHR2225CV33	RSHR2232CV33
400VACrms	24-550VAC/DC	-	In Line	RSHR4025CV32	RSHR4032CV32
			In Line	RSHR4025CV38	RSHR4032CV38
			(Scroll Compressors)		
			In Delta	RSHR4025CV33	RSHR4032CV33
480VACrms	24-550VAC/DC	-	In Line	RSHR4825CV32	RSHR4832CV32
			In Delta	RSHR4825CV33	RSHR4832CV33
600VACrms	24-660VAC/DC	-	In Line	RSHR6025DV32	RSHR6032DV32
			In Delta	RSHR6025DV33	RSHR6032DV33
400-480VACrms	24-550VAC/DC	24VAC/DC	In Line	RSHRM25CV34	RSHRM32CV34
220-480VACrms	24-550VAC/DC	24VAC/DC	In Delta	RSHRM25CV35	RSHRM32CV35

Motor Ratings - In Line

	RSHR..25.V3.	RSHR..32.V3.
Assigned motor rating / UL rating @ 40°C		
220VACrms	5.5kW / 7.5HP	9kW / 10HP
400VACrms	11kW / 10HP	15kW / 20HP
480VACrms	11kW / 15HP	18.5kW / 25HP
600VACrms	18.5kW / 20HP	22kW / 30HP
Assigned motor rating / UL rating @ 50°C		
220VACrms	5.5kW / 7.5HP	5.5kW / 7.5HP
400VACrms	11kW / 10HP	11kW / 15HP
480VACrms	11kW / 15HP	15kW / 20HP
600VACrms	15kW / 20HP	20kW / 25HP
Assigned motor rating / UL rating @ 60°C		
220VACrms	4kW / 5HP	4kW / 5HP
400VACrms	7.5kW / 10HP	7.5kW / 10HP
480VACrms	9kW / 10HP	9kW / 10HP
600VACrms	11kW / 15HP	11kW / 15HP

Motor Ratings - In Delta

	RSHR..25.V3.	RSHR..32.V3.
Assigned motor rating / UL rating @ 40°C		
220VACrms	11kW / 15HP	15kW / 20HP
400VACrms	20kW / 20HP	22kW / 30HP
480VACrms	22kW / 30HP	30kW / 40HP
600VACrms	30kW / 40HP	45kW / 50HP
Assigned motor rating / UL rating @ 50°C		
220VACrms	11kW / 10HP	11kW / 15HP
400VACrms	18.5kW / 20HP	22kW / 25HP
480VACrms	22kW / 25HP	22kW / 30HP
600VACrms	30kW / 30HP	30kW / 40HP
Assigned motor rating / UL rating @ 60°C		
220VACrms	7.5kW / 10HP	7.5kW / 10HP
400VACrms	11kW / 15HP	11kW / 15HP
480VACrms	15kW / 20HP	15kW / 20HP
600VACrms	22kW / 25HP	22kW / 25HP

Load Ratings

	RSHR2225CV3. RSHR4025CV3.	RSHR4825CV3. RSHR6025DV3. RSHRM25CV3.	RSHR..32.V3.
Rated operational current I _e (AC-53a) @ 40°C surrounding temp.	25 A	25 A	32 A
Overload cycle according to EN/IEC 60947-4-2 @ 40°C	25A: AC-53a: 4-4: 50-7	25A: AC53a: 4-4: 50-3	32A: AC-53 a: 4-4: 50-50
Number of starts per hour @ 40°C *	7	3	50
Rated operational current I _e (AC-53a) @ 50°C surrounding temp.	23 A	23 A	27 A
Overload cycle according to EN/IEC 60947-4-2 @ 50°C	23A: AC-53a: 4-4: 50-6	23A: AC-53a: 4-4: 50-3	27A: AC-53a: 4-4: 50-70
Number of starts per hour @ 50°C *	6	3	70
Rated operational current I _e (AC-53a) @ 60°C surrounding temp.	18 A	18 A	18 A
Overload cycle according to EN/IEC 60947-4-2 @ 60°C	18A: AC-53 a: 4-4: 50-50	18A: AC-53 a: 4-4: 50-30	18A: AC-53 a: 4-4: 50-215
Number of starts per hour @ 60°C *	50	30	215
Minimum load current	500 mA	500 mA	500 mA

* Refer to Overload Cycle and Starting Duty Section for the allowable no. of starts at various load currents

Conductor Data

Line conductors: L1, L2, L3/T1, T2, T3 according to IEC 60947	0.75...16mm ²
maximum size	
solid	2.5...16mm ²
finely stranded with end sleeve	2.5...16mm ²
stranded	2.5...25mm ²
UL/CSA rated data	AWG 14...4
Terminal screws	6xM5 (cage clamp)
Tightening torque	1.5...2.5 Nm /13...22 lb.in
Stripping length	10 mm
Secondary conductors: A1, A2, A3, A4, 11, 21, 22, P1, P2 according to IEC 60947	0.75...2.5mm ²
maximum size	0.5...2.5mm ²
UL/CSA rated data	AWG 22...12
Terminal screws	9xM3 (cage clamp)
Tightening torque	0.3...0.5 Nm/2.7...4.5 lb.in
Stripping length	6 mm

Standards

Approvals	UL, cUL (E172877), CCC
Markings	CE
Norms	LVD; EN 60947-4-2 EMCD; EN 60947-4-2

Environmental Specifications

Operating temperature	-20°C to +60°C (-4°F to +140°F)
Storage temperature	-50°C to +85°C (-58°F to +185°F)
Relative humidity	<95% non-condensing @40°C
Pollution Degree	3
Degree of Protection	IP20 (EN/IEC 60529)
Installation Category	III
Installation Altitude	Above 1000m derate linearly by 1% of unit FLC per 100m to a maximum altitude of 2000m

External Supply Specifications*

External supply voltage	24VDC/AC +/-20%
Rated AC frequency	50/60Hz +/-10%
Dielectric strength	
Dielectric withstand voltage	
Supply (A3, A4) to output	2.5 kV
Supply (A3, A4) to input	4 kV
Supply (A3, A4) to heatsink	4 kV

* Applies to RSHRM models only

Supply Specification

Rated operational voltage Ue through L1, L2 L3	
RSHR22..	127/220VAC -15% / +10%
RSHR40..	230/400VAC -15% / +10%
RSHR48..	277/480VAC -15% / +10%
RSHR60..	346/600VAC -15% / +10%
RSHRM...V34	400-480VAC -15% / +10%
RSHRM...V35	220-480VAC -15% / +10%
Rated AC frequency	50/60Hz +/-10%
Rated insulation voltage	630V
Dielectric strength	
Dielectric withstand voltage	
Supply to input	4 kVrms
Supply to heatsink	4 kVrms
Rated impulse withstand voltage	6 kV (1.2/50µs)

Input Specifications

Rated control input voltage U _c , A1:A2	
RSHR...CV3.	24 - 550VAC/DC
RSHR60..DV3.	24-600 +10% VAC/DC
Max. control input current	3.0 mA
Rated AC frequency	50/60Hz +/-10%
Response time input to output*	100 ms
Dielectric strength	
Dielectric withstand voltage	
Input to heatsink	4 kVrms
Rated impulse withstand voltage	6 kV (1.2/50µs)

* During idling condition

General Specifications

Ramp up time	1...10s	Phase loss	
RSHR...V38	0...1s	Phase loss alarm* ^{2,3}	LED, red (blinking at 2Hz)
Ramp down time	0...30s	Motor PTC alarm input P1, P2	Acc. to DIN 44081 and DIN 44082-1
RSHR...V38	0...1s	Form designation	Form 1
Initial torque	0...70%	Auxiliary relays:	
Status indicator LEDs		End of ramp relay activation	Normally open (21,22)
Power supply ON	LED, green (continuous)	Over-temperature, phase sequence, phase loss alarm	Normally closed (11, 22)
Ramping	LED, yellow (intermittent)	Auxiliary relay contact capacity	3 A, 250 VAC 3 A, 30 VDC
End of ramp	LED, yellow (continuous)	Weight	approx. 1.3kg
Ramp/ End* ¹ (RSHR...V38)	LED, yellow (intermittent/continuous)	Housing material	conforms to UL 94 V0
Delay* ¹ (RSHR...V38)	LED, yellow (continuous)	Mounting	DIN Rail 35 mm
Over-temperature alarm			
Device alarm	LED, red (intermittent)		
Motor PTC alarm	LED, red (continuous)		
Wrong phase sequence* ²	LED, red (intermittent)		

*¹ In the RSHR...V38 versions, the same LED is used to indicate both Ramping and End Ramp status. When the RSHR is in ramping mode, the LED will be intermittently ON. Once the Ramping is completed, the same LED will go fully ON indicating End of Ramp. The delay feature available in the RSHR...V38 does not allow the compressor to start prior to 5 mins. from last ramp down. During this waiting period the Delay LED will be intermittently ON.

*² Detection of these alarm conditions is made during power-up of the device.

*³ Phase loss alarm applies on loss of L3 only. For RSHRM, phase loss alarm applies on loss of any of the 3 phases (L1, L2 or L3). During operation, the RSHRM will issue an alarm and performs shut down in case ALL 3 phases are lost. This will prevent a DOL start when the supply is restored, in case the 24V external supply remains present.

Operation Diagram

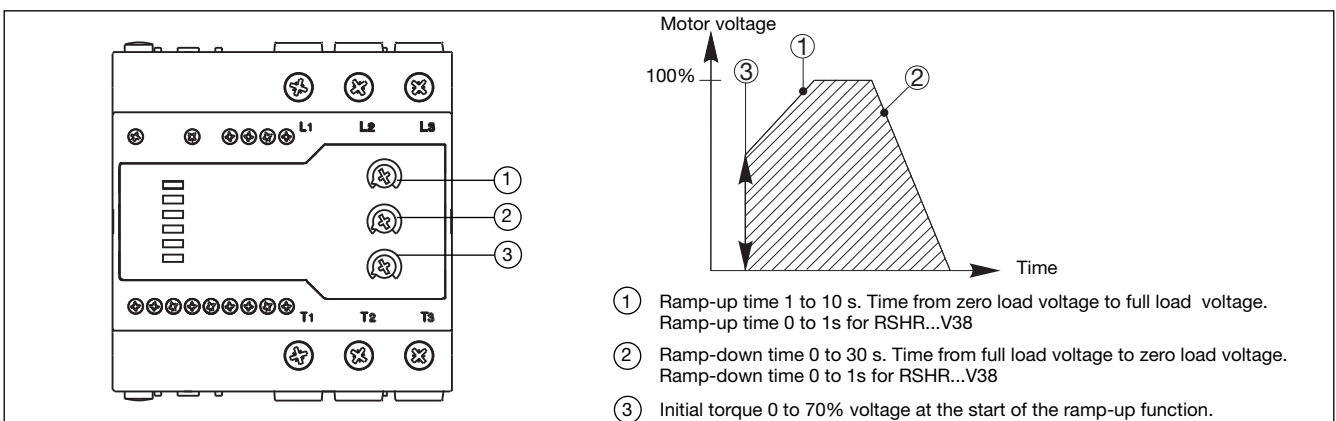

Connection Diagram - In Delta

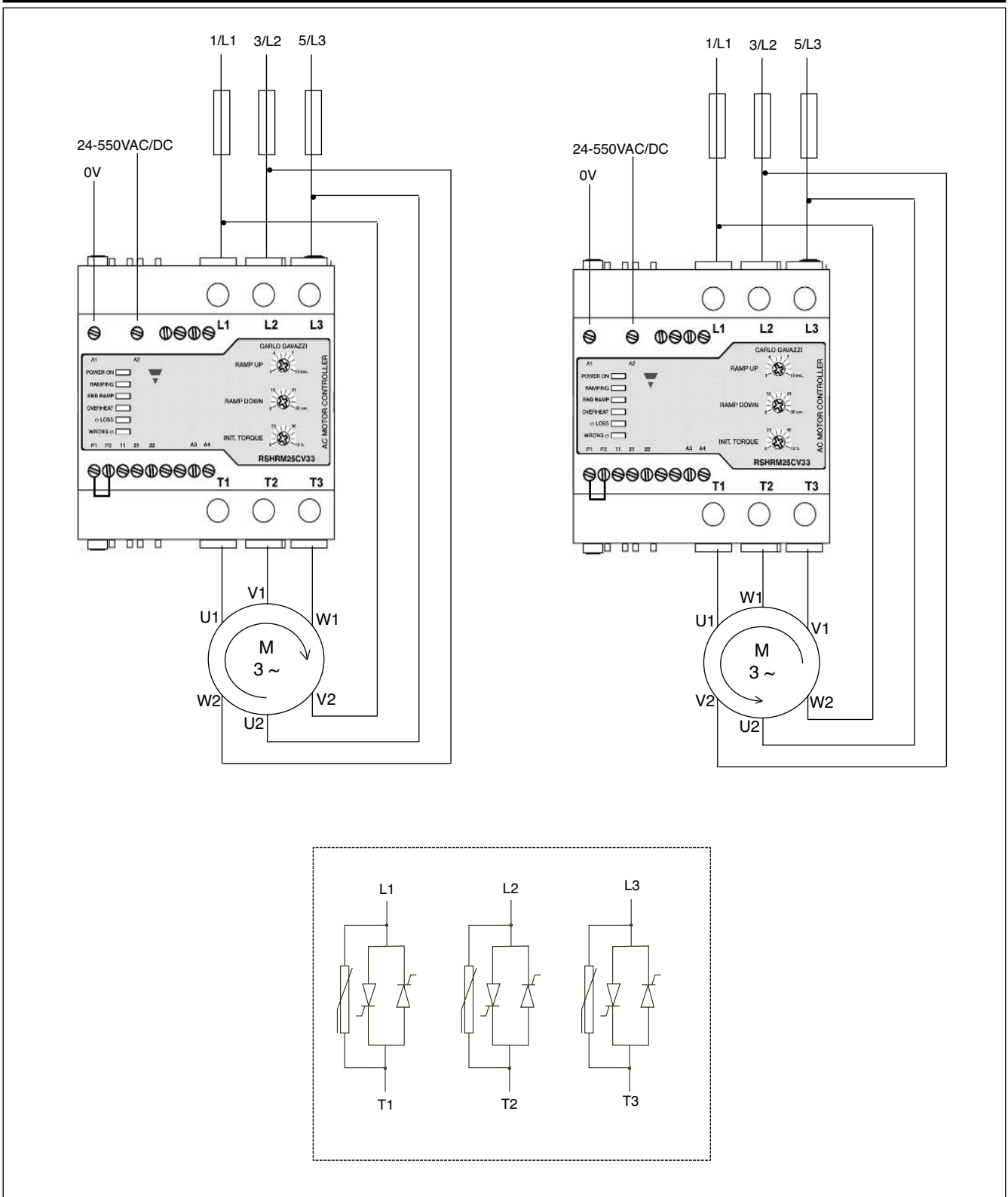

NOTES:

1. A3, A4 24VAC/DC used only for RSHRM models
2. A1, A2 24-660VAC/DC for RSHR60..DV33 models
3. In order to have the motor rotating in an another direction it is necessary to swap 2 motor windings as indicated.

Connection Diagram - In Line

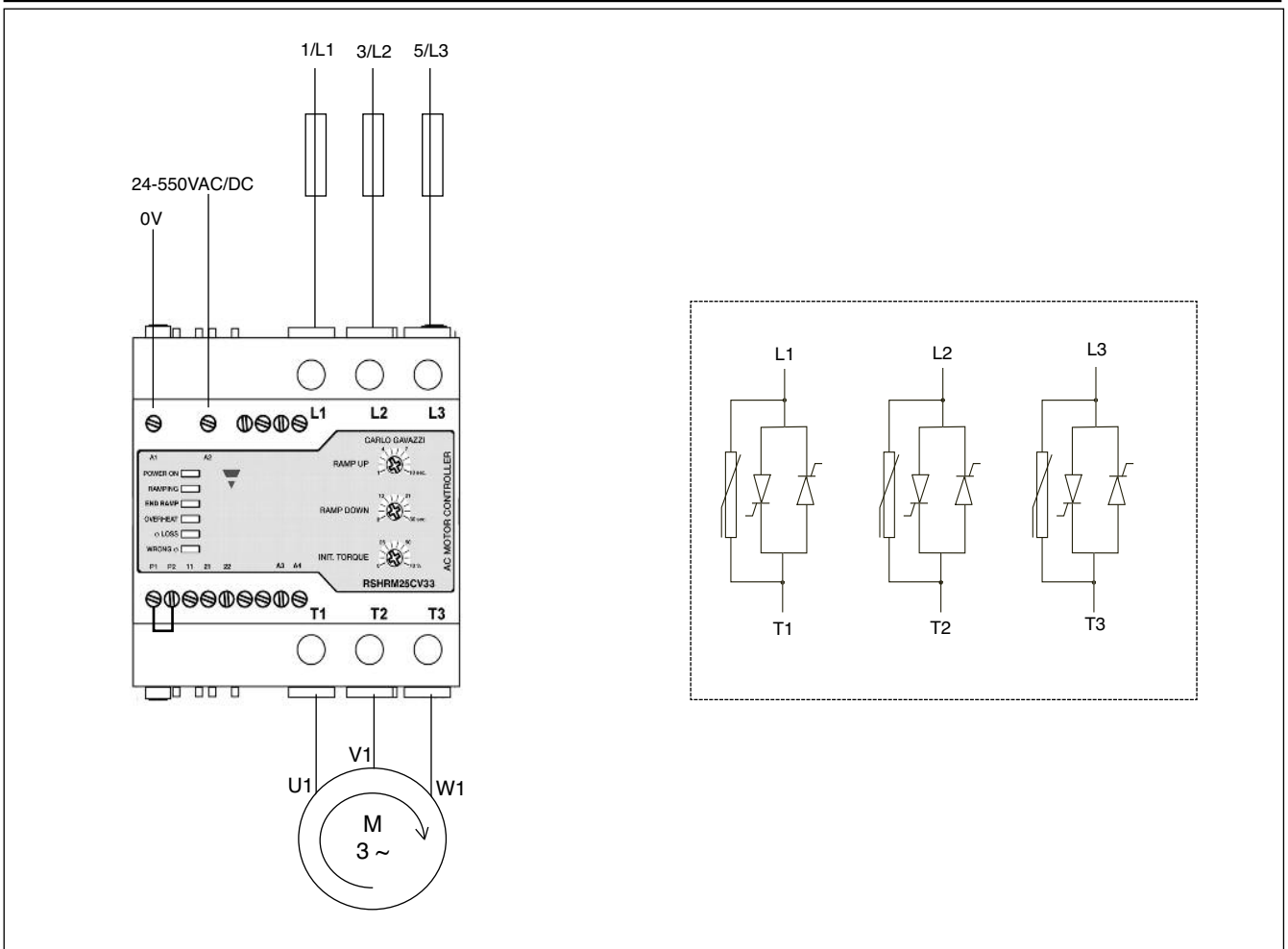

NOTES:

1. A3, A4 24VAC/DC used only for RSHRM models
2. A1, A2 24-660VAC/DC for RSHR60..DV32 models

Terminal Diagram

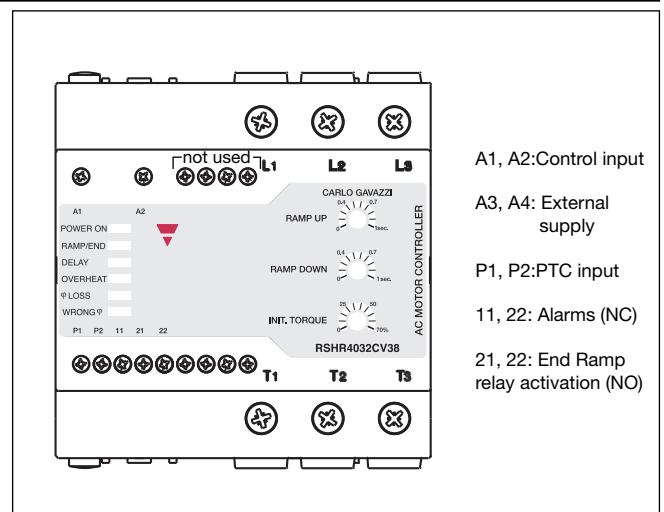
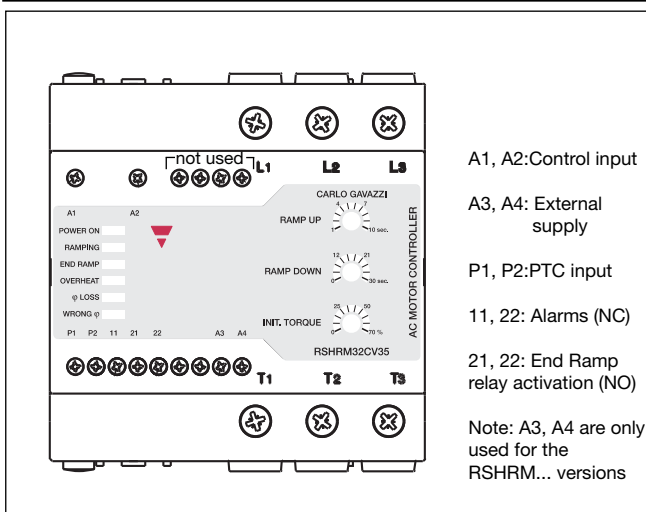

Dimensions

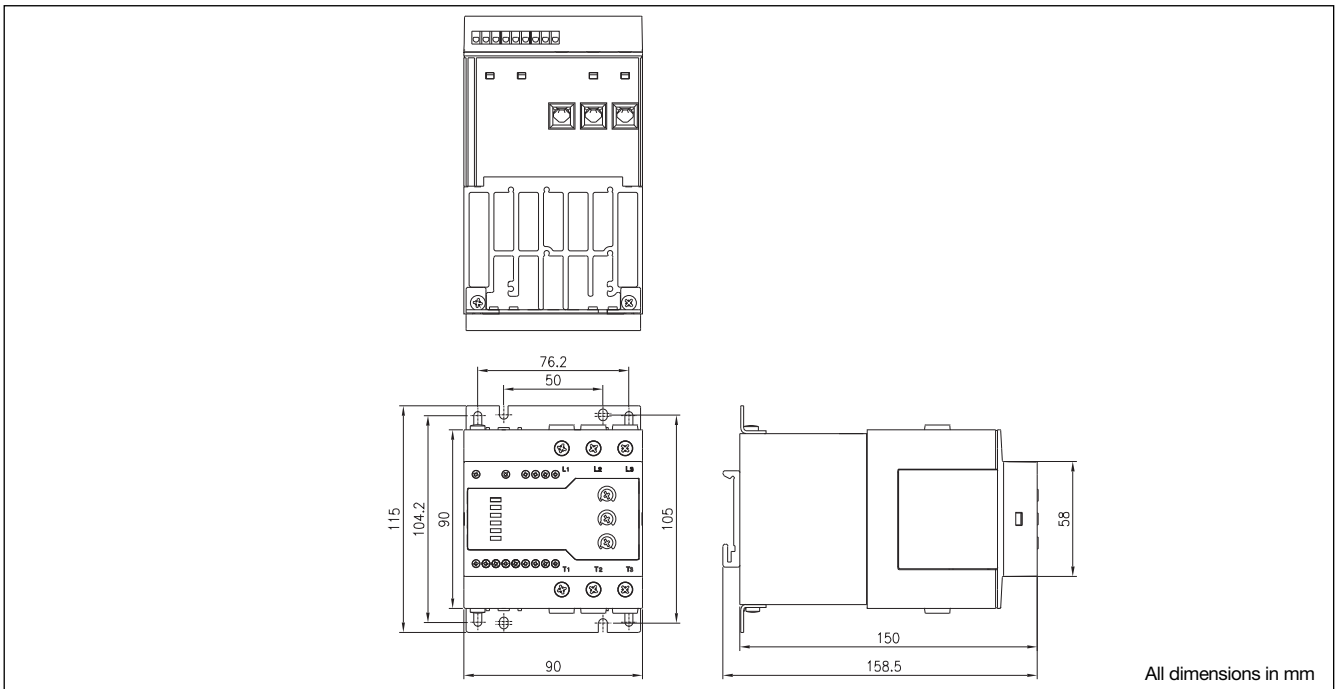

NOTE: Panel mounting bracket is an accessory that has to be ordered separately

Short Circuit Protection

	RSHR..25.V3.	RSHR..32.V3.
Type of coordination: 1		
UL rated short circuit current	10kA when protected by fast acting Class J fuses*	10kA when protected by fast acting Class J fuses*
Class J (Fast Acting) fuse rating		
RSHR22...V32/4/8	80A	110A
RSHR40...V32/4/8	70A	125A
RSHR48...V32/4/8	80A	125A
RSHR60...V32/4/8	80A	125A
RSHR22...V33/5	150A	200A
RSHR40...V33/5	125A	200A
RSHR48...V33/5	150A	200A
RSHR60...V33/5	150A	200A
Type of coordination: 2		
Rated short circuit current	10kA when protected by semiconductor fuses	10kA when protected by semiconductor fuses
Semiconductor fuse	Ferraz Shawmut model, A70 QS60-4	Ferraz Shawmut model, A70 QS100-4

* such as series JLS from Littlefuse

Wiring Diagram

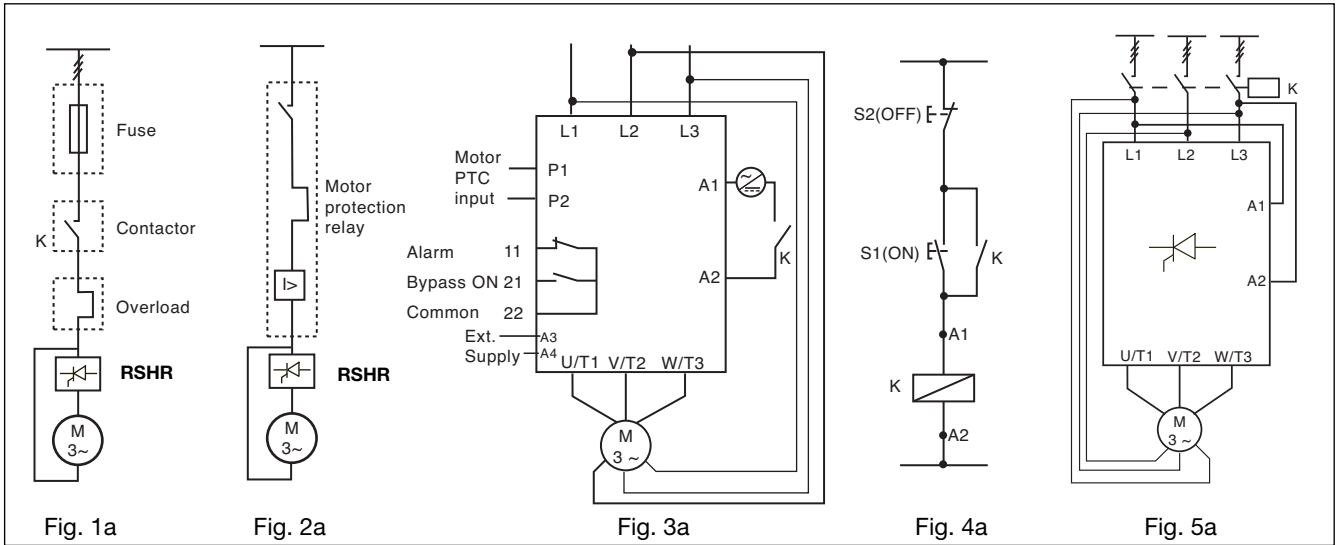

IEC

The RSHR 3-Phase does not include internal bypass relays. As such semiconductors can be damaged by short-circuit currents during Ramp up, Ramp Down and Running. Please note that the motor controller does not isolate the motor from the mains.

Figure 1: Protection of the device when using fuses. Protection with semiconductor fuses is intended to protect the motor feeder and motor controller from damage due to short-circuit.

Figure 2: Protection using a thermal-magnetic motor protection relay. The motor feeder is protected but damage to the motor controller is possible. When motor failure occurs, if part of the motor winding limits the fault current and the motor feeder is protected, this type of protection can be considered acceptable.

Figure 3: Secondary conductors.
 3.1: Control using a 2-position switch
 When K is closed, the control input is supplied to A1, A2 and soft starting of the motor is performed. When K is opened, soft stopping is performed.

3.2: Motor PTC input
 When the motor PTC sensor is connected to P1, P2 the motor controller detects overheating of the motor windings.

3.3: Auxiliary Relays
 The Alarm relay 11, 22 (NC) can be connected in series with the supply to the coil of a mains contactor. The End of Ramp relay 21, 22 (NO) can be used in series with the supply to the coil of an external bypass contactor.

Figure 4: Control using ON and OFF push buttons
 Pushing S1 soft starts the RSHR. Pushing S2 soft stops the RSHR. K is an auxiliary

contact of the mains contactor.

Figure 5: Control using 2 phases
 Connecting input A1, A2 to two of the incoming lines will soft start the motor when K is operated. When K is switched off, the motor will stop (no soft stop).

Note: In the indicated wiring diagram the RSHR is configured In Delta. Models RSHR...V32/V34/V38 should be configured In Line as shown in the Connection diagram

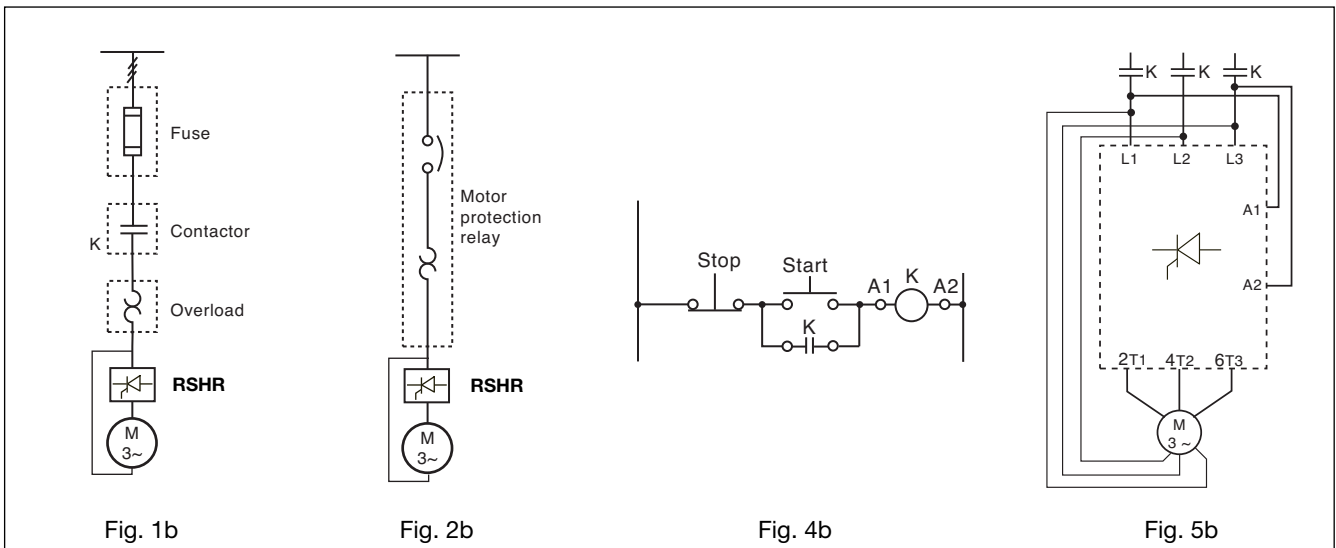

NEMA

Operations diagram for RSHR 3-Phase

Diagram 1a: Normal Operation

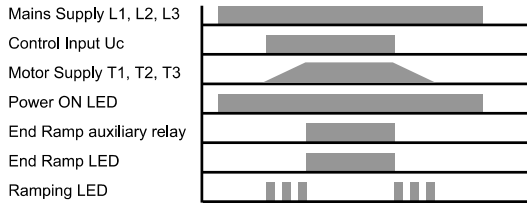

Diagram 1b: Normal Operation for RSHRM models

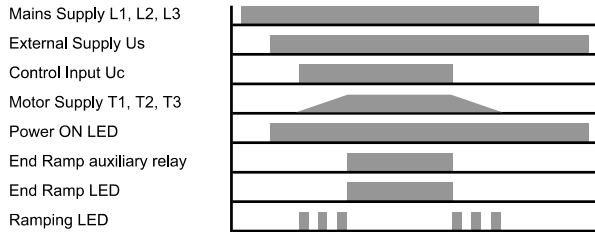

Diagram 2a: Device over-temperature alarm

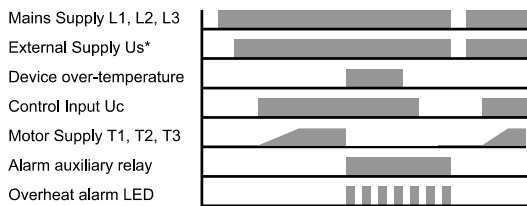

Diagram 2b: Motor PTC alarm



Diagram 2c: Phase sequence

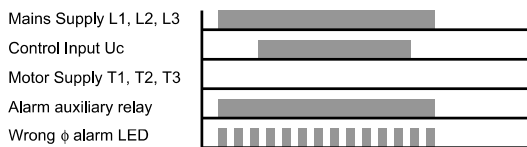

Diagram 2d: Phase sequence for RSHM models

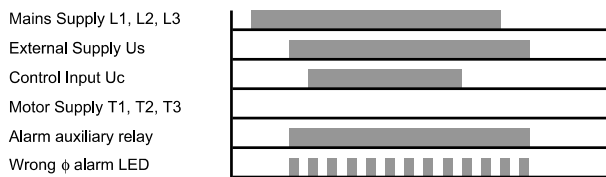

Diagram 2e: Phase loss on POWER UP

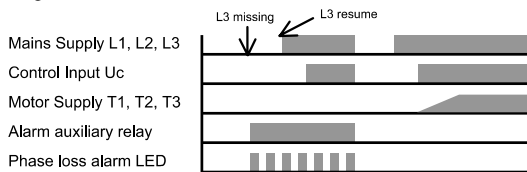

Diagram 2f: Phase loss on POWER UP for RSHRM models

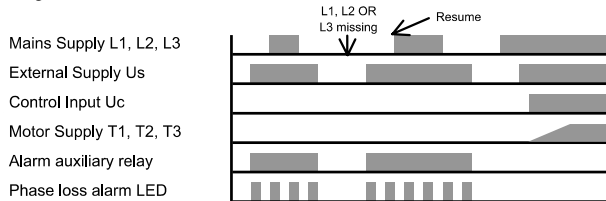

Diagram 2g: Phase loss during OPERATION

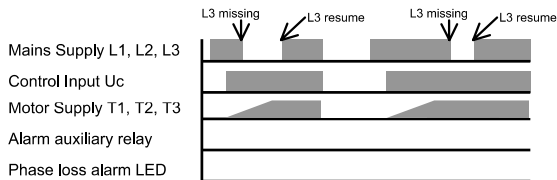

Diagram 2h: Phase loss during OPERATION for RSHM models

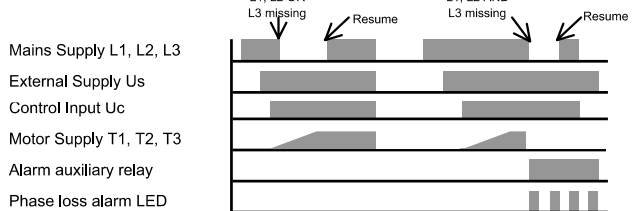

Diagram 3a: Normal Operation for RSHR..V38 models

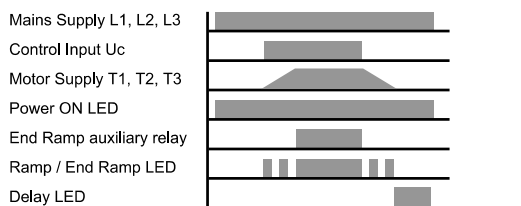
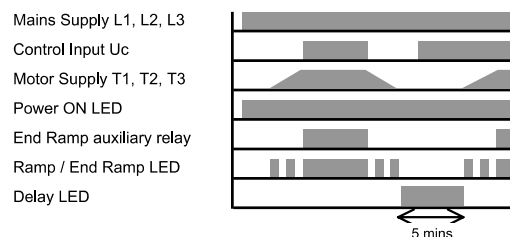

Diagram 3b: Delay ON



* External supply applies to RSHRM models only



Operations diagram for RSHR 3-Phase (cont.)

Notes:

Note 1: In the RSHRM models, the POWER ON Led does not give any indication to the presence of the mains voltage at L1, L2 and L3, since it goes ON only once the external supply is applied.

Note 2: The number of starts per hr. and overload cycle values should always be taken in consideration when the control input is cycled.

Note 3: Over-temperature is checked before Phase loss and Phase sequence alarms. The alarms will be activated as soon as the supply is applied.

Note 4: Apart from the RSHRM models, a Phase loss on L1 or L2 will cause the device to reset.

Note 5: When a motor PTC is connected, electromagnetic noise may be conducted into the unit. Thus if abnormal function is observed, the use of ferrite beads on the PTC wire (at the unit end) is recommended.

Note 6: Phase loss and Phase sequence are only checked on start up. In the case of the RSHRM, a phase loss of ALL 3 phases is detected during operation (ramping and running).

Note 7: Following Ramp Down, the Delay LED remains ON for 5 mins. or until the mains supply is present, whichever is the shortest. The compressor will not start in case of an attempt to start during the Delay period. Once the 5 mins. have elapsed the compressor will start as long as the control signal remains present.

Overload Cycle & Starting Duty

Overload profile

In: AC-53a: x- Tx : F-S

where: In = nominal current through RSHR

x = overload current as a multiple of In

Tx = duration time for the controlled overload currents during starting

F = duty cycle (expressed as a percentage)

S = no of starts/hr.

The following tables indicate the allowable no. of starts as per Overload profile: In: AC-53a: 4-4: 50-S

Table 1: RSHRxx25CV3., where xx = 22 or 40

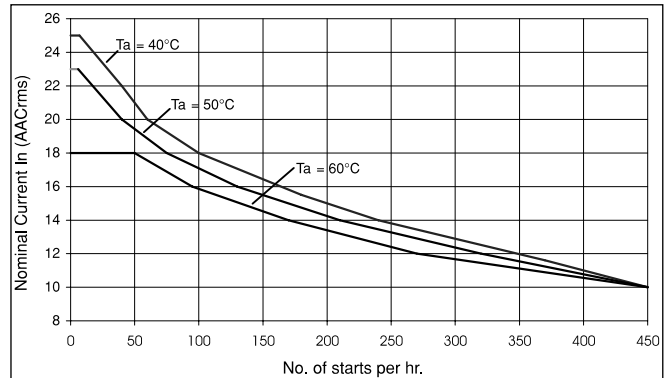

Multiple devices can be used with 0mm spacing

Table 2: RSHRxx25yV3., where xx = 48, 60 or M and y = C or D

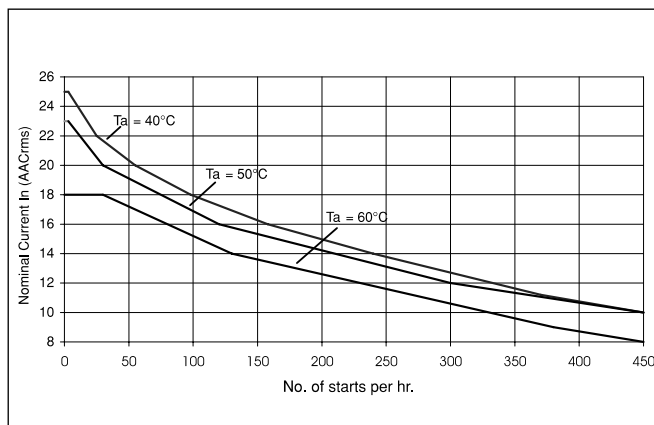

The indicated current ratings apply only when a clearance of 30mm is applied on each side of the device. When multiple devices are used with 0mm spacing, a 15% derating factor on current rating is required for surrounding ambients up to 50°C

Table 3: RSHRxx32yV3., where xx = 22, 40, 48, 60 or M and y = C or D

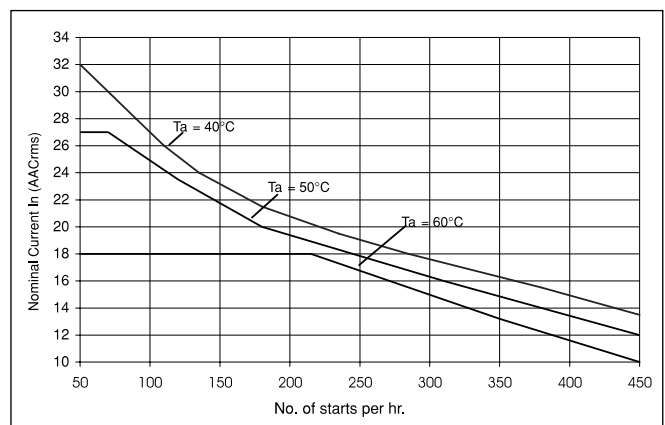

The indicated current ratings apply only when a clearance of 50mm is applied on each side of the device. When multiple devices are used with 0mm spacing, a 15% derating factor on current rating is required for surrounding ambients up to 50°C