

Smart Dupline® PIR Sensor and Luxmeter Type SHSDP90L

CARLO GAVAZZI



- Passive infrared detector (PIR) with built-in luxmeter
- Light measuring range: 0 to 20 klux
- Indoor applications
- Detects movement and presence
- Smart-house output
- Operating distance: 12 m
- Operating angle: 90°
- LED indication
- Supplied by bus

Product Description

The SHSDP90L is a 90° PIR sensor to detect presence and/or movement in indoor installations with built-in luxmeter, combining two products in one. It is part of the smart-house concept and can be used to control lights,

rollerblinds, air-conditioning, intruder alarms and all the other functions supported by the smart-house system, in an automatic way depending on people-presence. This sensor is completely programmable via the SH tool.

Ordering Key

SH SD P 90 L

smart-house _____
 Wall mounting _____
 PIR sensor _____
 Detection angle _____
 Luxmeter _____

Type Selection

Housing	Degree of protection	LED	Supply by bus
104 x 52 x 62 mm	IP40	1 red	SHSDP90L

Input Specifications

Infrared inputs	PIR
Lens	Dual detecting zones
Angle	90°
Operating distance	≤ 12 m
Luxmeter	
Characteristic deviation	-3% to +3%
Response time	It depends on the number of variables in the system
Sensor range	0 to 20 kLux
Output accuracy over temperature	0° to 40°C ± 10% -30° to 0°C ± 15% 40° to 60°C ± 20%

Dupline® Output Specifications

Voltage	8.2 V
Maximum Dupline® voltage	10 V
Minimum Dupline® voltage	5.5 V
Maximum Dupline® current	5.5 mA

Output Specifications

Output	Red LED
LED output	

Supply Specifications

Power supply	Supplied by bus
---------------------	-----------------

General Specifications

Address assignment	Automatic: the controller recognises the module through the SIN (Specific Identification Number) that has to be inserted in the SH tool.	Connection	Screwless detachable	0.2 to 1.5 mm ²
			D+	Signal
			D-	GND
		Weight		Approx. 150 g
Environment		Housing		
Degree of protection	IP 40	Material		ABS
Pollution degree	3 (IEC 60664)	Colour		White
Operating temperature	0° to +50°C (+32° to +122°F)	Lens		Polyethylene
Storage temperature	-20° to +70°C (-4° to +158°F)	Dimensions (WxHxD)		104 x 52 x 62 mm
Humidity (non condensing)	20 to 80%	CE Marking		Yes

General Specifications (cont.)

EMC			
Immunity	EN 61000-6-2	- Voltage dips, variations, interruptions	EN 61000-4-11
- Electrostatic discharge	EN 61000-4-2	Emission	EN 61000-6-3
- Radiated radiofrequency	EN 61000-4-3	- Conducted and radiated emissions	CISPR 22 (EN55022), cl. B
- Burst immunity	EN 61000-4-4	- Conducted emissions	CISPR 16-2-1 (EN55016-2-1)
- Surge	EN 61000-4-5	- Radiated emissions	CISPR 16-2-3 (EN55016-2-3)
- Conducted radio frequency	EN 61000-4-6		
- Power frequency magnetic fields	EN 61000-4-8		

Mode of Operation

This PIR sensor responds to any fluctuation in infrared heat radiation, so any object or human presence changes the thermal image detected by the sensor when entering its field of vision.

The sensor is equipped with a segmented lens that divides the field of vision into active and passive zones (zones not visible to the sensor, see figures "Horizontal and Vertical sensitive area"). When a heat source crosses these zones, the sensor detects the change in infrared radiation and presence and/or movement are recognised.

How sensitive and fast the sensor has to be to detect presence and/or movement can be programmed by means of four parameters, by means of the SH tool.

The four parameters are: mode of detecting the crossing of active zones, sensitivity, the number of pulses and the time window in which these pulses have to be detected. These four parameters have to be set for both presence and movement recognition. Movement is used by the system in the intruder alarm function and to switch the light on, while presence is used in the light function to reload the energy-save timer (i.e. each time presence is detected, the energy-save timer starts counting from the beginning).

1) Mode of detection

A: one border between the active and the passive zone has to be crossed to give a pulse signal. This option has

to be selected for presence detection and movement and turns the light on as soon as a person moves from an active to a passive area or vice versa (very quick response).

B: two borders have to be crossed to give a pulse signal. The person has to move from an active area to another active area, passing through a passive one or vice versa.

This option is recommended for sensors used in the intruder alarm function, in order to avoid false alarms.

2) Sensitivity

A number can be set from 3 to 100: the smaller this value is, the longer the detection distance, but the higher the sensitivity to heating sources. In the figures "Horizontal and Vertical sensitive area", three

examples of different sensitivity can be seen.

3) Number of pulses

The number of pulses is calculated according to mode A or B before sending a people detection message to the controller. This can be set from 1 to 8.

4) Time window

This is the time interval within which the predefined number of pulses is detected. It can be set from 1 to 10 seconds.

In the table below is an example of settings which, of course, might depend on environmental conditions, application and type of installation.

	Presence	Movement (light fx)	Movement (alarm fx)
Mode of detection	A	A	B
Sensitivity	10..30	30..70	50..100
Number of pulses	1	1	3
Time window	10	2	10

Active and passive zones

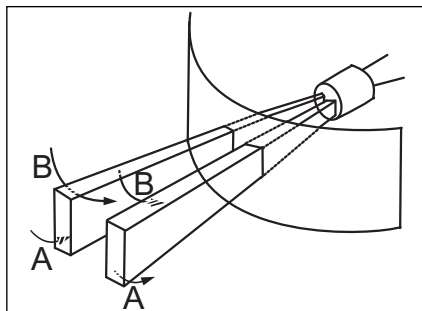

Mode of Operation (cont.)

Horizontal sensitive area

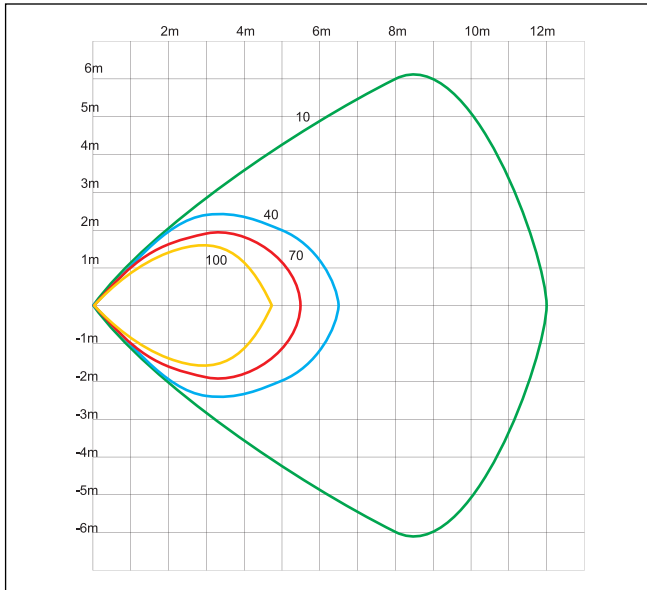

Vertical sensitive area

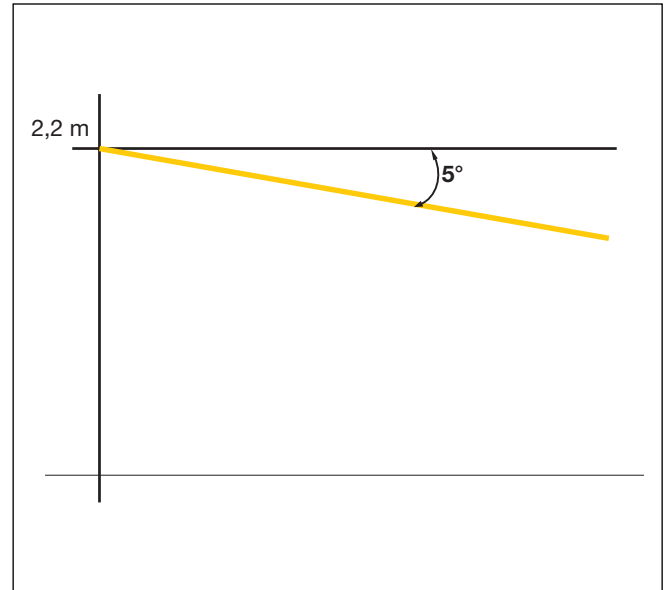

LED programming

There is one configurable LED (red) on board the SHSDP90L to be programmed.

Red LED: the user can select one of the following options:

1. LED always OFF
2. LED flashes shortly every second if a presence/movement is detected
3. LED flashes shortly every second if it is used as feedback of a function status

If the red LED is not programmed, it is always OFF.

Coding/Addressing

If the input module is connected to the SH2WEB24 controller, no addressing is needed since the module is

provided with a specific identification number (SIN): the user has only to insert the SIN number in the SH tool when creating the system configuration.

Used channels: 2 input channels, 1 output channel.

Mounting

The PIR detector is designed for wall mounting. As the SHSDP90L is a passive device, several detectors can be placed in the same room without interfering with each other. The module should not be installed as follows:

- a) Outdoors
- b) In places exposed either to sunlight or to motor vehicle headlights pointing directly at the sensor.
- c) In places exposed to direct air flow from a heater or air conditioner.
- d) In places where rapid

- e) temperature changes occur.
- e) In places exposed to severe vibration.
- f) Close to glass or other objects which might reflect the infrared radiation.

Note: If the sensor is to detect presence, please be careful to mount it so that the area where presence has to be detected is completely covered by the sensitive area of the sensor. See figures "Horizontal and Vertical sensitive area".

Wiring Diagram

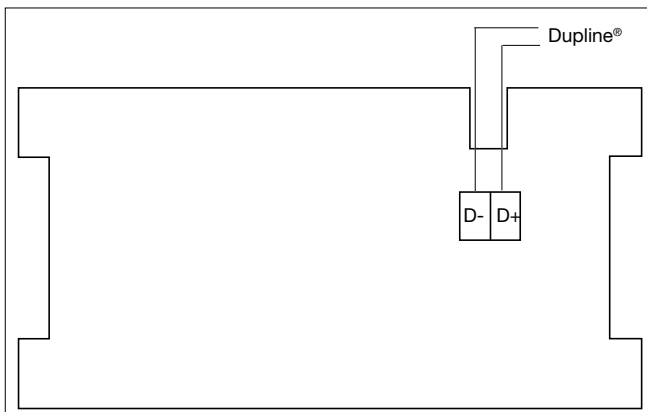

Dimensions

