

Smart Dupline® Aurora line, PIR Sensor Type SHA4XP150

CARLO GAVAZZI



- Passive infrared presence/movement detector
- Developed to fit into wall socket and frames from Fuga, Niko, Biticino
- Indoor applications
- Operating distance: max. 10 m
- Supplied by bus, no external power required
- Programmable white and blue LED for presence and movement detection
- Delivered with 2 white and 1 black push-button covers

Product Description

The SHA4XP150 is a 150° PIR sensor to detect presence and/or movement in indoor installations. It is part of the smart-house concept and can be used to control lights, rollerblinds, air-conditioning, intruder alarms and

all the other functions supported by the smart-house system, in an automatic way depending on people-presence. This sensor is completely programmable via the SH tool.

Ordering Key

SH A4 X P 150

smart-house _____
Housing 44 x 44 mm _____
Standard _____
Pir Sensor _____
Detection angle _____

Type Selection

Housing	Colour	LEDs	Supply by bus
44 x 44 mm	White / Black *	1 white / 1 blue	SHA4XP150

* Delivered with white and black push-button covers.

Input Specifications

Inputs	
Lens	Dual detecting zones
Angle	150°
Operating distance	≤ 10 m

Dupline® Specifications

Voltage	8.2 V
Maximum Dupline® voltage	10 V
Minimum Dupline® voltage	5.5 V
Maximum Dupline® current	5.8 mA

Output Specifications

Output LED	1 blue / 1 white
-------------------	------------------

Supply Specifications

Power supply	Supplied by bus
---------------------	-----------------



General Specifications

Address assignment	Automatic: the controller recognises the module through the SIN (Specific Identification Number) that has to be inserted in the SH tool.	Weight	50 g
Environment	Degree of protection Pollution degree Operating temperature Storage temperature Humidity (non-condensing)	CE Marking	Yes
Connection	Screwless detachable D+ D-	EMC	Immunity - Electrostatic discharge - Radiated radiofrequency - Burst immunity - Surge - Conducted radio frequency - Power frequency magnetic fields - Voltage dips, variations, interruptions Emission - Conducted and radiated emissions - Conducted emissions - Radiated emissions
Housing	Back part dimensions Back part + front dimensions Back part material Push button covers		EN 61000-6-2 EN 61000-4-2 EN 61000-4-3 EN 61000-4-4 EN 61000-4-5 EN 61000-4-6 EN 61000-4-8 EN 61000-4-11 EN 61000-6-3 CISPR 22 (EN55022), cl. B CISPR 16-2-1 (EN55016-2-1) CISPR 16-2-3 (EN55016-2-3)
Accessories	0.2 to 1.5 mm ² Signal GND 44 x 44 x 25.2 mm 44 x 44 x 43 mm Plastic, transparent Plastic white (RAL 9010) Plastic clear white (RAL 9016) Plastic black Transparent plastic ring for Bticino frame		

Mode of Operation

This PIR sensor responds to any fluctuation in infrared heat radiation, so any object or human presence changes the thermal image detected by the sensor when entering its field of vision.

The sensor is equipped with a segmented lens that divides the field of vision into active and passive zones (zones not visible to the sensor, see figures "Horizontal and Vertical sensitive area"). When a heat source crosses these zones, the sensor detects the change in infrared radiation and presence and/or movement are recognised.

How sensitive and fast the sensor has to be to detect presence and/or movement can be programmed by means of four parameters, by means of the SH tool if the sensor is controlled by a

master unit SH2WEB24.

The four parameters are: mode of detecting the crossing of active zones, sensitivity, the number of pulses and the time window in which these pulses have to be detected. These four parameters have to be set for both presence and movement recognition.

Movement is used by the system in the intruder alarm function and to switch the light on, while presence is used in the light function to reload the energy-save timer (i.e. each time presence is detected, the energy-save timer starts counting from the beginning).

1) Mode of detection

A: one border between the active and the passive zone has to be crossed to give a pulse signal. This option has

to be selected for presence detection and movement and turns the light on as soon as a person moves from an active to a passive area or vice versa (very quick response).

B: two borders have to be crossed to give a pulse signal. The person has to move from an active area to another active area, passing through a passive one or vice versa.

This option is recommended for sensors used in the intruder alarm function, in order to avoid false alarms.

2) Sensitivity

A number can be set from 3 to 100: the smaller this value is, the longer the detection distance, but the higher the sensitivity to heating sources.

In the figures "Horizontal

and Vertical sensitive area", three examples of different sensitivity can be seen.

3) Number of pulses

The number of pulses is calculated according to mode A or B before sending a people detection message to the controller. This can be set from 1 to 8.

4) Time window

This is the time interval within which the predefined number of pulses is detected. It can be set from 1 to 10 seconds.

In the table below is an example of settings which, of course, might depend on environmental conditions, application and type of installation.

	Presence	Movement (light fx)	Movement (alarm fx)
Mode of detection	A	A	B
Sensitivity	10..30	30..70	50..100
Number of pulses	1	1	3
Time window	10	2	10

Mode of Operation (cont.)

Active and passive zones

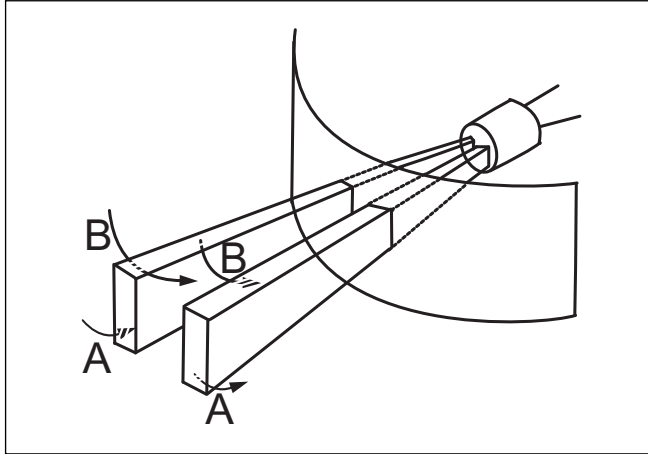

Vertical sensitive area

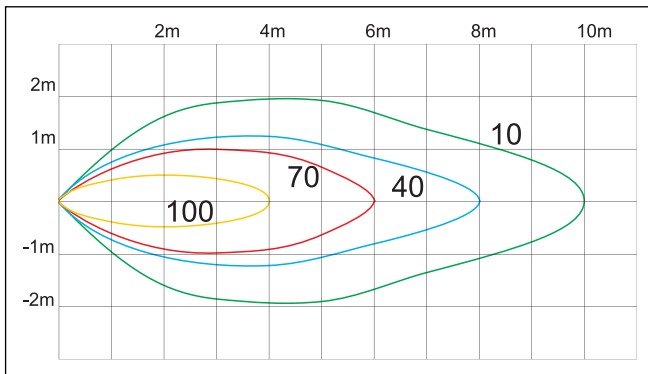

Horizontal sensitive area

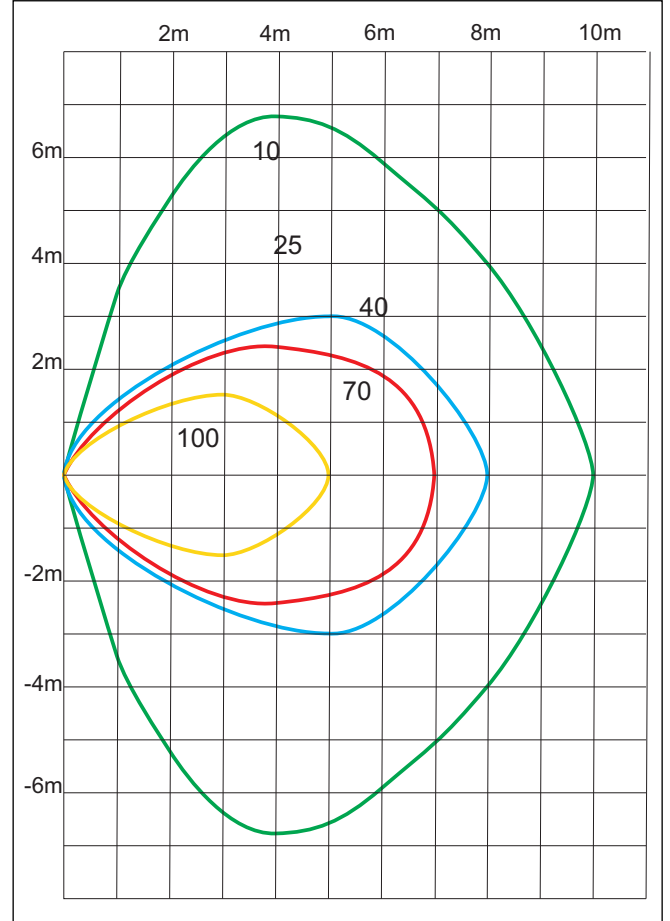

SHA4XP150 connected to the SH2WEB24

If the PIR sensor is connected to the SH2WEB24, the number of pulses for presence and movement detection, the interval period, the sensitivity as well as the LED functions are programmed with a very user friendly interface in the tool (see SH tool manual). The detection speed (number of pulses in a time interval) and the sensitivity have to be defined as described above.

LED programming

There are two configurable LEDs (one white and one blue), built in the SHA4XP150, to be programmed.

White LED: the user can select one of the following options

1. LED always OFF
2. LED programmed as guide light: it is always ON
3. LED ON when a presence is detected
4. LED ON when a movement is detected

If the white LED is not programmed, it is always OFF.

Blue LED: the user can select one of the following options

1. LED always OFF
2. LED ON when a presence is detected
3. LED ON when a movement is detected

If the blue LED is not programmed, it is always OFF.

Coding/Addressing

If the input module is connected to the SH2WEB24 controller, no addressing is needed since the module is provided with a specific identification number (SIN): the user has only to insert the SIN number in the SH tool when creating the system configuration.

Used channel: 2 input channels, 1 output channel.

Mounting

The PIR detector is designed for mounting at a standard switch height (1,1 m). As the SHA4XP150 is a passive device, several detectors can be placed in the same room without interfering with each other.

The module should not be installed as follows:

- Outdoors.
- In places exposed either to sunlight or to motor vehicle headlights pointing directly at the sensor.
- In places exposed to direct air flow from a heater

or air conditioner.

- In places where rapid temperature changes occur.
- In places exposed to severe vibration.
- Close to glass or other objects which might reflect the infrared radiation.

Note: If the sensor is to detect presence, please be careful to mount it so that the area where presence has to be detected is completely covered by the sensitive area of the sensor. See figures "Horizontal and Vertical sensitive area".

Dimensions

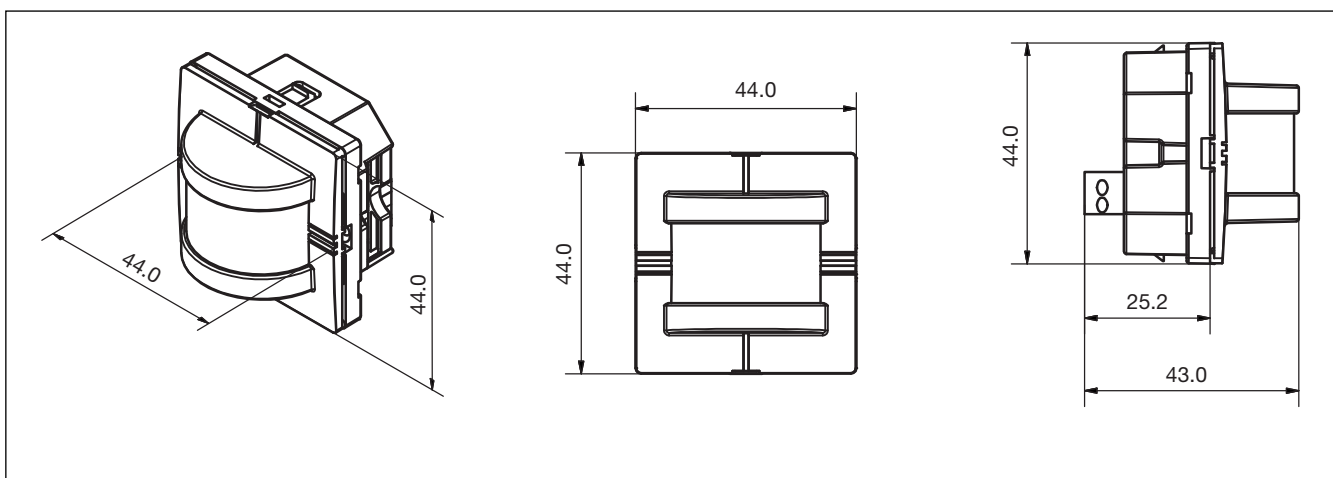

Wiring Diagram

