



## Quick Start Guide Motor Controllers AC Variable Frequency Drives Type VariFlex<sup>3</sup> RVLF

# Switch



# Index

<b>0. Preface</b>	
0.1. Preface	0
<b>1. Safety Precautions</b>	<b>2</b>
1.1. Before power UP	2
1.2. During power UP	3
1.3. Before operation	3
1.4. During operation	4
1.5. Inverter disposal	4
<b>2. Part Number Definition</b>	<b>5</b>
2.1. Model part number	5
<b>3. Environment &amp; Installation</b>	<b>6</b>
3.1. Wiring and EMC guidelines	6
3.2. Considerations for peripheral equipment	7
3.3. Specification	8
3.3.1 Product specifications	8
3.3.2 General specifications	9
3.4. Single phase (PNP input)	11
3.4.1 Three phase (PNP input)	12
3.5. Terminal description	13
3.5.1 Description of main circuit terminals	13
3.5.2 Control circuit terminal description	14
3.6. Outline dimensions	15
<b>4. Software Index</b>	<b>17</b>
4.1. Keypad description	17
4.1.1 Operator panel functions	17
4.2. Programmable parameter groups	18
<b>5. Troubleshooting and Maintenance</b>	<b>31</b>
5.1. Error display and corrective action	31
5.1.1 Manual reset and auto-Rreset	31
5.1.2 Keypad operation error instruction	34
5.1.3 Special conditions	35
5.2. General troubleshooting	36



## 0.1 Preface

To extend the performance of the product and ensure personnel safety, please read this manual thoroughly before using the inverter. Should there be any problem in using the product that cannot be solved with the information provided in the manual, contact our technical or sales representative who will be willing to help you.

### Precautions

The inverter is an electrical product. For your safety, there are symbols such as “Danger”, “Caution” in this manual as a reminder to pay attention to safety instructions on handling, installing, operating, and checking the inverter. Be sure to follow the instructions for highest safety.

**Danger** Indicates a potential hazard that could cause death or serious personal injury if misused.

**Caution** Indicates that the inverter or the mechanical system might be damaged if misused.

### Danger

- Risk of electric shock. The DC link capacitors remain charged for five minutes after power has been removed. It is not permissible to open the equipment until 5 minutes after the power has been removed.
- Do not make any connections when the inverter is powered on. Do not check parts and signals on circuit boards during the inverter operation.
- Do not disassemble the inverter or modify any internal wires, circuits, or parts.
- Ground the ground terminal of the inverter properly.

### Caution

- Do not perform a voltage test on parts inside the inverter. High voltage can destroy the semiconductor components.
- Do not connect T1, T2, and T3 terminals of the inverter to any AC input power supply.
- CMOS ICs on the inverter’s main board are susceptible to static electricity. Do not touch the main circuit board.



# 1. Safety Precautions

## 1.1. Before Power Up

---

**Danger** Make sure the main circuit connections are correct. Single phase L1 (L), L3 (N), and three phase L1(L), L2, L3 (N); 400V: L1, L2, L3 are power-input terminals and must not be mistaken for T1, T2 and T3. Otherwise, inverter damage can result.

### Caution

- The line voltage applied must comply with the inverter's specified input voltage. (See the nameplate).
- To avoid the front cover from disengaging, or other damage do not carry the inverter by its covers. Support the drive by the heat sink when transporting. Improper handling can damage the inverter or injure personnel and should be avoided.
- To avoid the risk of fire, do not install the inverter on a flammable object. Install on nonflammable objects such as metal.
- If several inverters are placed in the same control panel, provide heat removal means to maintain the temperature below 50°C to avoid overheat or fire.
- When removing or installing the operator, turn the power off first, and follow the instructions in the diagram to avoid operator error or no display caused by bad connections.

### Warning

- This product is sold subject to EN 61800-3 and EN 61800-5-1. In a domestic environment this product may cause radio interference in which case the user may be required to apply corrective measures.
- Motor over temperature protection is not provided.

### Caution

- Work on the device/system by unqualified personnel or failure to comply with warnings can result in severe personal injury or serious damage to material. Only suitably qualified personnel trained in the setup, installation, commissioning and operation of the product should carry out work on the device/system.
- Only permanently-wired input power connections are allowed.



## 1.2. During Power Up

---

- Danger** When the momentary power loss is longer than 2 seconds, the inverter will not have sufficient stored power for its control circuit. Therefore, when the power is re-applied, the run operation of the inverter will be based on the setup of following parameters:
- Run parameters. 00-02 or 00-03.
  - Direct run on power up. Parameter. 07-04 and the status of external run switch,

**Note:** The start operation will be regardless of the settings for parameters 07-00/07-01/07-02.

### **Danger direct run on power up.**

If direct run on power up is enabled and inverter is set to external run with the run FWD/REV switch closed then the inverter will restart.

### **Danger**

- Prior to use, ensure that all risks and safety implications are considered.
- When the momentary power loss ride through is selected and the power loss is short, the inverter will have sufficient stored power for its control circuits to function, therefore, when the power is resumed the inverter will automatically restart depending on the setup of parameters 07-00 & 07-01.

## 1.3. Before Operation

---

**Caution** Make sure the model and inverter capacity are the same as that set in parameter 13-00.

**Note:** On power up the supply voltage set in parameter 01-01 will flash on display for 2 seconds.



## 1.4. During Operation

---

**Danger** Do not connect or disconnect the motor during operation. Otherwise, it may cause the inverter to trip or damage the unit.

**Danger**

- To avoid electric shock, do not take the front cover off while power is on.
- The motor will restart automatically after stop when auto-restart function is enabled. In this case, care must be taken while working around the drive and associated equipment.
- The operation of the stop switch is different than that of the emergency stop switch. The stop switch has to be activated to be effective. Emergency stop has to be deactivated to become effective.

**Caution**

- Do not touch heat radiating components such as heat sinks and brake resistors.
- The inverter can drive the motor from low speed to high speed. Verify the allowable speed ranges of the motor and the associated machinery.
- Note the settings related to the braking unit.
- Risk of electric shock. The DC link capacitors remain charged for five minutes after power has been removed. It is not permissible to open the equipment until 5 minutes after the power has been removed.

**Caution**

- The Inverter should be used in environments with temperature range from (14 to +104°F) or (-10 to +40°C) and relative humidity of 95%.

**Note:** models with fan: -10~+50°C, models without fan: -10~+40°C

**Danger**

- Make sure that the power is switched off before disassembling or checking any components.

## 1.5. Inverter Disposal

---

**Caution**

Please dispose of this unit with care as an industrial waste and according to your required local regulations.

- The capacitors of inverter main circuit and printed circuit board are considered as hazardous waste and must not be burnt.
- The plastic enclosure and parts of the inverter such as the cover board will release harmful gases if burnt.



## 2. Part Number Definition

### 2.1. Model Part Number

#### Ordering Key **RVLf A 1 20 075 F**

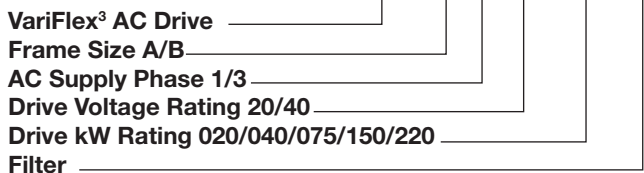

Frame Size	AC Supply Phase	Drive Voltage Rating	Drive kW Rating
A: Size 1 B: Size 2	1: 1-Phase 3: 3-Phase	20: 200-240VAC 40: 380-480VAC	020: 0.20kW, 0.25HP
			040: 0.40kW, 0.50HP
			075: 0.75kW, 1.0HP
			150: 1.5kW, 2.0HP
			220: 2.2kW, 3.0HP



### 3. Environment & Installation

#### 3.1. Wiring and EMC Guidelines

For effective interference suppression, do not route power and control cables in the same conduit or trucking. To prevent radiated noise, motor cable should be put in a metal conduit. Alternatively an armored or shielded type motor cable should be used.

For effective suppression of noise emissions the cable armor or shield must be grounded at both ends to the motor and the inverter ground. These connections should be as short as possible. Motor cable and signal lines of other control equipment should be at the least 30 cm apart.

RVLF has a built in Class “A” EMC filter to first environment restricted. (Category C2). For some installations such as residential, (Category C1) an optional external Class “B” type filter will be necessary. Please consult your local supplier.

#### Typical Wiring.

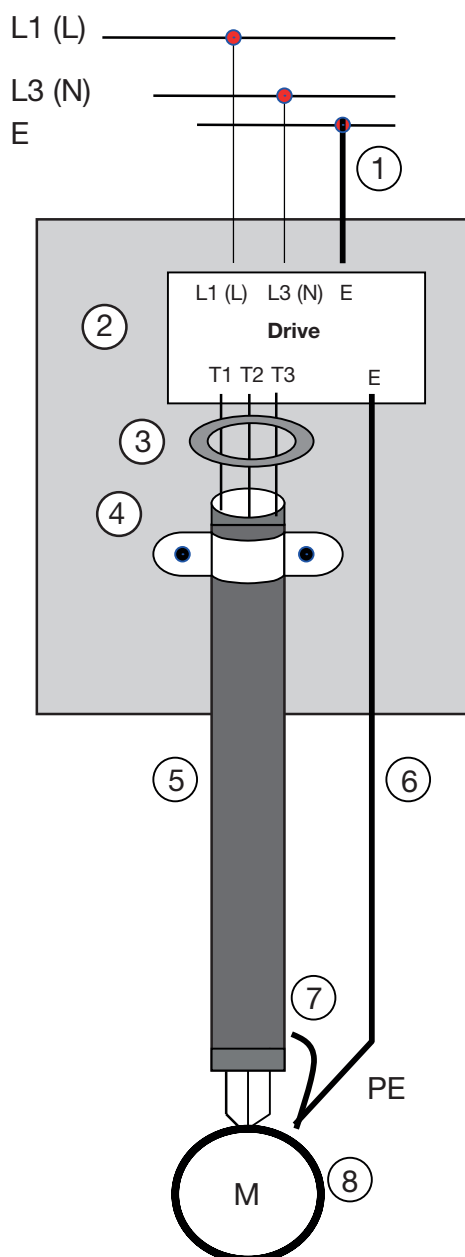

1. Protective earth conductor.  
Conductor size for enclosure & back plate must comply with the local electrical standards. Min 10mm<sup>2</sup>.
2. Back plate. Galvanised steel (Unpainted).
3. Ferrite core/Output reactor ferrite cores can be used to reduce radiated noise due to long motor cables. If ferrite core is used loop motor wires, 3 times round the core. Install core as close to the inverter as possible.

Output reactors provide additional benefit of reducing dv/dt for protection of motor windings.

4. Metal cable clamp. no more than 150mm from the inverter.
- Note: If no enclosure & back plate is used then connect the cable shield by a good 360° termination to the Inverter output terminal E.
5. Screened (shielded four core cable).
6. Separate protective earth wire, routed outside motor cable separated be at least 100mm.





Note: this is the preferred method specially for large output cables and long length. Multi core screened (3 core & protective earth) can be used for small power and short length.

7. Connect the cable shield by a good 360° termination and connect to the motor protective earth terminal. This link must be as short as possible.
8. Motor earth terminal (protective earth).



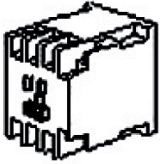
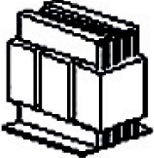

### 3.2 Considerations for Peripheral Equipment

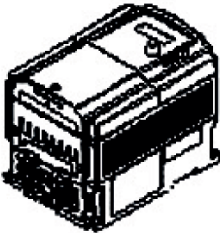
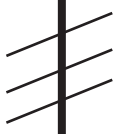
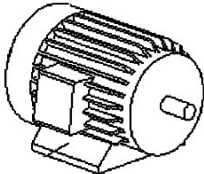
	Power	Ensure that the supply voltage is correct. A molded-case circuit breaker or fused disconnect must be installed between the AC source and the inverter.
	Circuit Breaker & RCD	Use a molded-case circuit breaker that conforms to the rated voltage and current of the inverter. Do not use the circuit breaker as the run/stop switch for the inverter. Residual current circuit breaker (RCD). Current setting should be 200mA or above and the operating time at 0.1 second or longer to prevent malfunctions.
	Magnetic contactor	Normally a magnetic contactor is not needed. A contactor can be used to perform functions such as external control and auto restart after power failure. Do not use the magnetic contactor as the run/stop switch for the inverter.
	AC reactor for power quality improvement	When a 200V/400V inverter with rating below 15KW is connected to a high capacity power source (600KVA or above) then an AC reactor can be connected for power factor improvement and reducing harmonics.
	Input noise filter	RVLf inverter has a built-in filter to Class "A" first environment. (Category C2). To satisfy the required EMC regulations for your specific application you may require an additional EMC filter.
 	Inverter	Connect the single phase power to terminals, L1 (L) & L3 (N) and three phase power to terminals: (200V: L1 (L), L2, L3 (N) or 400V: L1, L2, L3). Warning! Connecting the input terminals T1, T2, and T3 to AC input power will damage the inverter. Output terminals T1, T2, and T3 are connected to U, V, and W terminals of the motor. To reverse the motor rotation direction just swap any two wires at terminals T1, T2, and T3. Ground the Inverter and motor correctly. Ground resistance for 200V power <100 Ohms.
	Motor	Three-phase induction motor. Voltage drop on motor due to long cable can be calculated. Volts drop should be <10%. Phase-to-phase voltage drop (V)= $\sqrt{3}$ × resistance of wire (Ω/km) × length of line (m) × current × 10 <sup>-3</sup> .



### 3.3. Specifications

#### 3.3.1. Product Specifications

200V Class: Single phase.

F: Standards for built-in filter

<b>Model: RVLf</b>	120020	120040	120075	120150	120220
<b>Horse power (HP)</b>	0.25	0.5	1	2	3
<b>Suitable motor capacity (KW)</b>	0.2	0.4	0.75	1.5	2.2
<b>Rated output current (A)</b>	1.8	2.6	4.3	7.5	10.5
<b>Rated capacity (KVA)</b>	0.68	1.00	1.65	2.90	4.00
<b>Input voltage range (V)</b>	Single Phase: 200~240V, 50/60HZ				
<b>Allowable voltage fluctuation</b>	+10% / -15%				
<b>Output voltage range (V)</b>	Three phase 0~240V				
<b>Input current (A)</b>	4.9	7.2	11	15.5	21
<b>Allowable momentary power loss time (S)</b>	1.0	1.0	1.0	2.0	2.0
<b>Enclosure</b>	IP20				

400V Class: Three phase.

F: Standards for built-in filter

<b>Model: RVLf</b>	340075	340150	340220
<b>Horse power (HP)</b>	1	2	3
<b>Suitable motor capacity (KW)</b>	0.75	1.5	2.2
<b>Rated output current (A)</b>	2.3	3.8	5.2
<b>Rated capacity (KVA)</b>	1.7	2.9	4.0
<b>Input voltage range (V)</b>	Three Phase: 380~480V, 50/60HZ		
<b>Allowable voltage fluctuation</b>	+10% / -15%		
<b>Output voltage range (V)</b>	Three phase 0~480V		
<b>Input current (A)</b>	4.2	5.6	7.3
<b>Allowable momentary power loss time (S)</b>	2.0	2.0	2.0
<b>Enclosure</b>	IP20		



### 3.3.2. General Specifications

Item		RVLf
<b>Control Mode</b>		V/F Control + Auto-torque compensation function
<b>Frequency</b>	Range	0.01~650.00Hz
	Setting resolution	Digital input: 0.01Hz Analog input: 0.06Hz/60Hz
	Setting	Keypad: set directly with keys or the VR (potentiometer) on the keypad
		External input terminals: AVI (0/2~10V), ACI (0/4~20mA) input Multifunction input up/down function (Group3) Setting frequency by communication method.
Frequency limit	Lower and upper frequency limits 3-skip frequency settings.	
<b>Run</b>	Operation set	Keypad run, stop button
		External terminals: Multi-operation-mode 2/3 wire selection jog operation
		Run signal by communication method.
<b>Main Controls</b>	V/F curve setting	6 fixed curve and one customized curve
	Carrier frequency	1~16KHz (default 5KHz)
	Acceleration and deceleration control	2 off Acc/dec time parameters. 4 off S curve parameters.
	Multifunction input	19 functions (refer to description on group 3)
	Multifunction output	14 functions (refer to description on group 3)
	Multifunction analog output	5 functions (refer to description on group 4)
	Main features	Overload detection, 8 preset speeds, auto-run, acc/dec switch (2 stages), main/alt run command select, main/alt frequency command select, PID control, torque boost, V/F start frequency, fault reset.



<b>Display</b>	LED	Display: parameter/parameter value/frequency/line speed/DC voltage/output voltage/output current/PID feedback/input and output terminal status/heat sink temperature/program version/fault log.
	LED status indicator	For run/stop/forward and reverse.
<b>Protective functions</b>	Overload protection	Integrated motor and inverter overload protection.
	Over voltage	100V/200V: Over 410V, 400V: Over 820V
	Under voltage	100V/200V: Under 190V, 400V: Under 380V
	Momentary power loss restart	Inverter auto-restart after a momentary power loss.
	Stall prevention	Stall prevention for acceleration/deceleration/and continuous run.
	Short-circuit output terminal	Electronic circuit protection
	Grounding fault	Electronic circuit protection
	Additional protective functions	Heak sink over temperature protection, auto carrier frequency reduction with temperature rise, fault output, reverse prohibit, number of auto restart attempts, parameter lock
<b>International certification</b>		CE/UL
<b>Communication</b>		RS485 (Modbus) built in, with one to one or one to many control.
<b>Environment</b>	Operating temperature	-10~+50°C
	Storage temperature	-20~+60°C
	Humidity	Under 95%RH (no condensation)
	Shock	Under 20Hz, 1G (9.8m/s <sup>2</sup> ); 20-50Hz, 0.6G (5.88m/s <sup>2</sup> )
	EMC compliance	EN61800-3, first environment
	LVD compliance	EN50178
	Electrical safety	UL508C
	Protection level	IP20



### 3.4. 200V Single phase (PNP input)

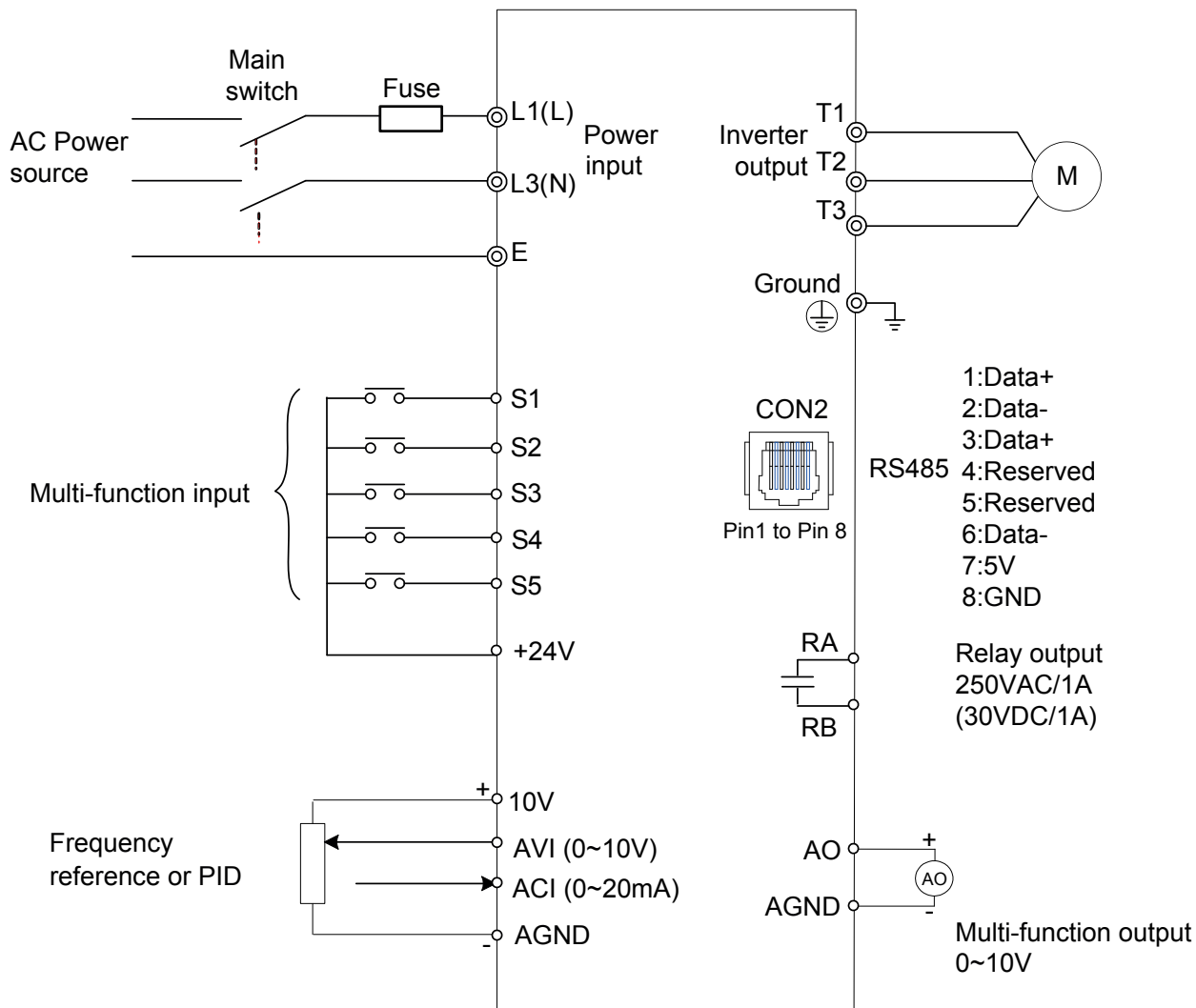

**Model:**

200V: RVLFA120020F / RVLFA120040F / RVLFA120075F,  
 RVLFB120150F / RVLFB120220F



### 3.4.1. 400V Three phase (PNP input)

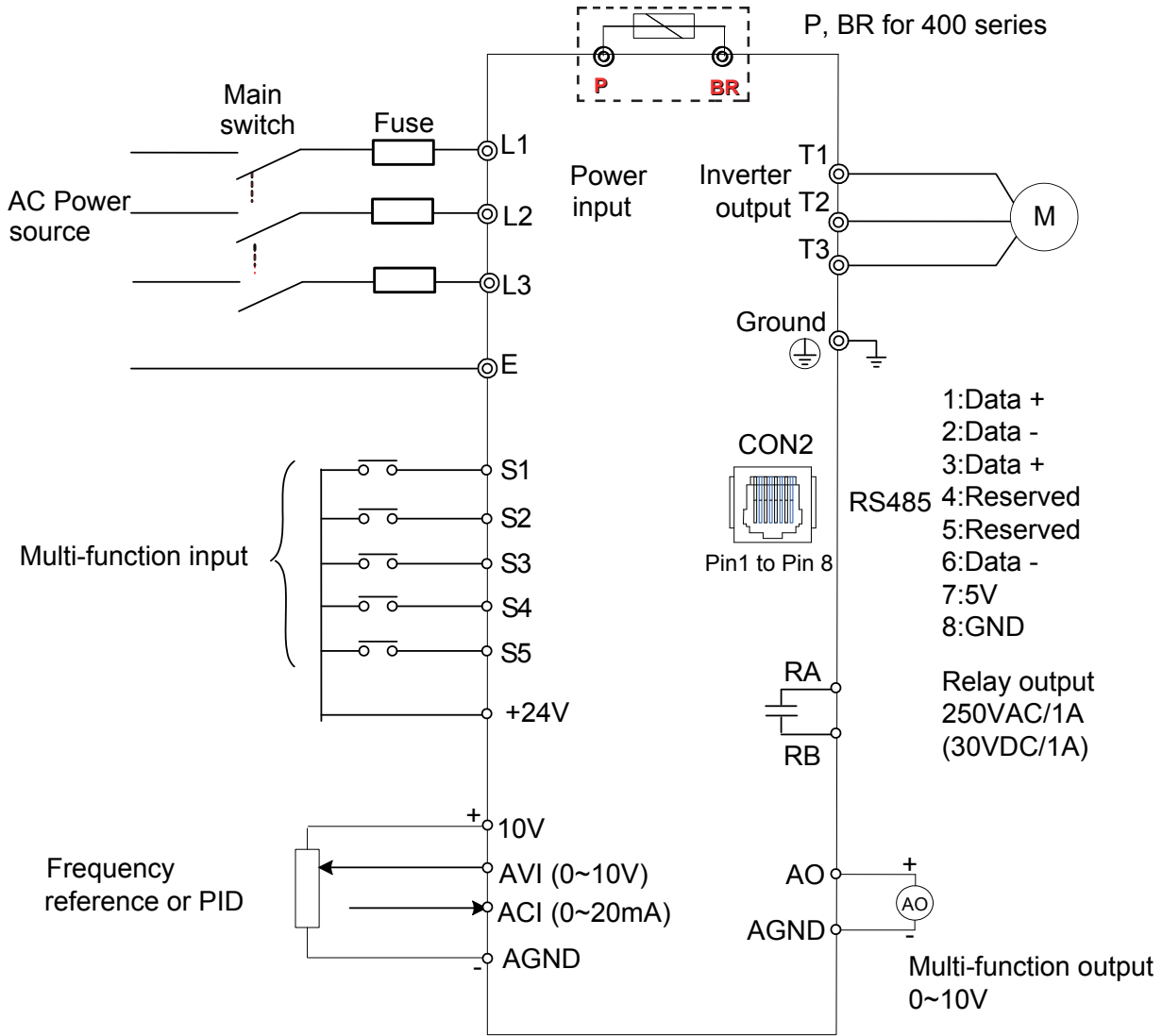

**Model:**

400V: RVLFB340075F / RVLFB340150F / RVLFB340220F



### 3.5. Terminal Description

#### 3.5.1. Description of Main Circuit Terminals

Terminal symbols	TM1 Function description
L1 (L)	Main power input, L1 (L)/L2/L3 (N)
L2	
L3 (N)	
P*	Externally connected braking resistor
BR*	
T1	Inverter output, connect to U, V, W terminals of motor
T2	
T3	
	Ground terminal

\*P, BR for 400V series

#### Single phase

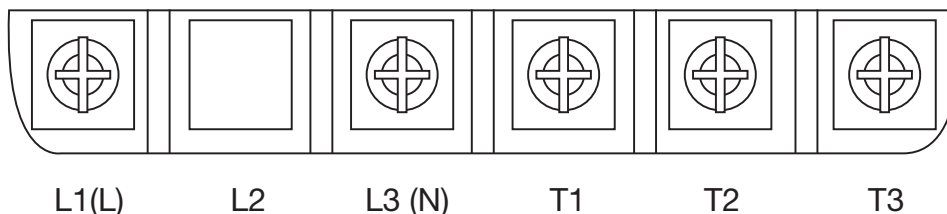

Note: the screw on L2 terminal is removed for the single phase input supply models.

#### Three phase (400V series)

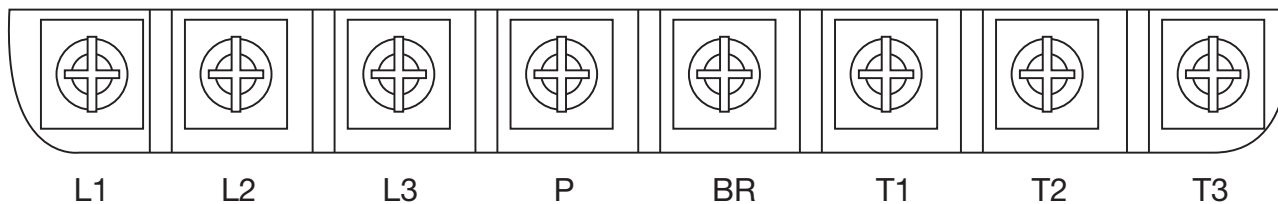



### 3.5.2. Control Circuit Terminal Description

Terminal symbols	TM1 Function Description
RA	Relay output terminal, Specification: 250VAC/1A(30VDC/1A)
RB	
+24V	S1~S5 (COMMON) PNP
S1	Multi-function input terminals (refer to group3)
S2	
S3	
S4	
S5	
10V	Built in power for an external speed potentiometer
AVI	Analog voltage input, specification: 0~10VDC/ 2-10V
ACI	Analog current input, specification: 0/4~20mA
AO	Multi function analog output terminal. Maximum output 10VDC/1mA
AGND	Analog ground terminal

**PNP:**

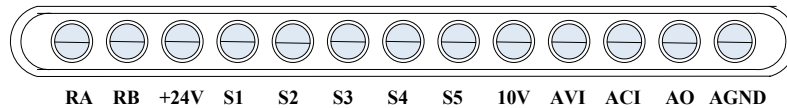





### 3.6. Outline Dimensions

(unit: mm)

Size 1

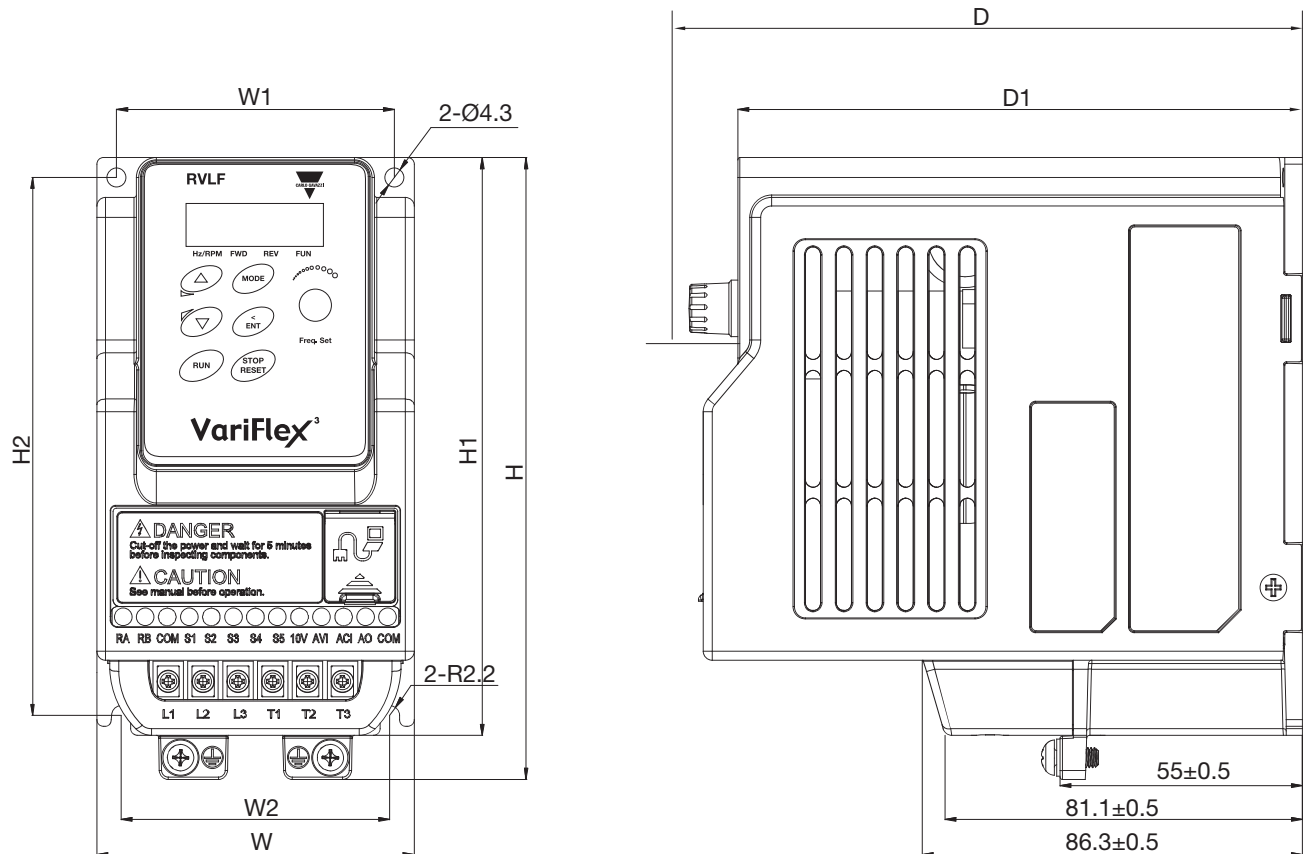

Model	W	W1	W2	H	H1	H2	D	D1	Weight
RVLFA120020F	72 (2.83)	63 (2.48)	61 (2.40)	141 (5.55)	131 (5.16)	122 (4.80)	144.2 (5.69)	136 (5.35)	0.9kg
RVLFA120040F									
RVLFA120075F									

F: Built-in EMC filter



Size 2

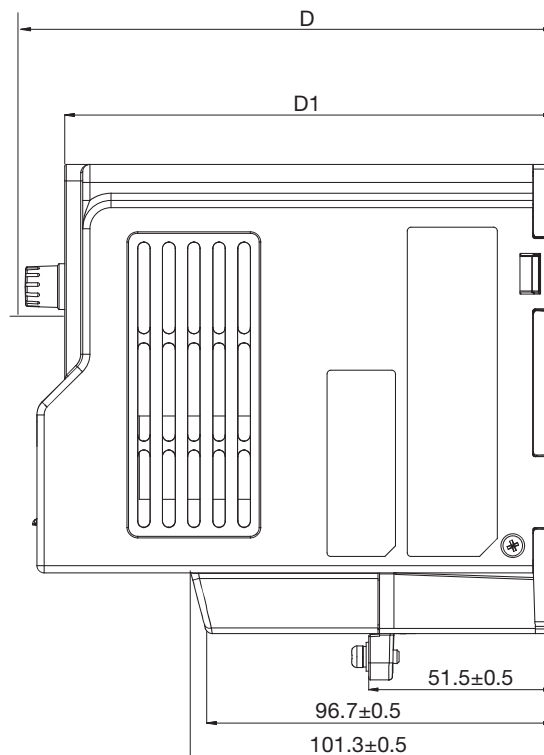
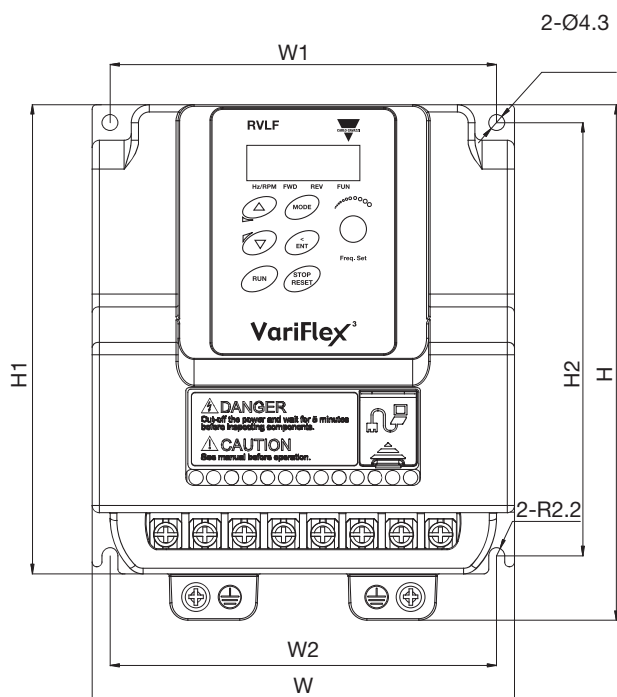

Model	W	W1	W2	H	H1	H2	D	D1	Weight
RVLFB120150F	118 (4.65)	108 (4.25)	108 (4.25)	144 (5.67)	131 (5.16)	121 (4.76)	152.25 (6.01)	144.2 (5.68)	1.6kg
RVLFB120220F									
RVLFB340075F									
RVLFB340150F									
RVLFB340220F									

F: Built-in EMC filter



## 4. Software Index

### 4.1. Keypad Description

#### 4.1.1. Operator Panel Functions

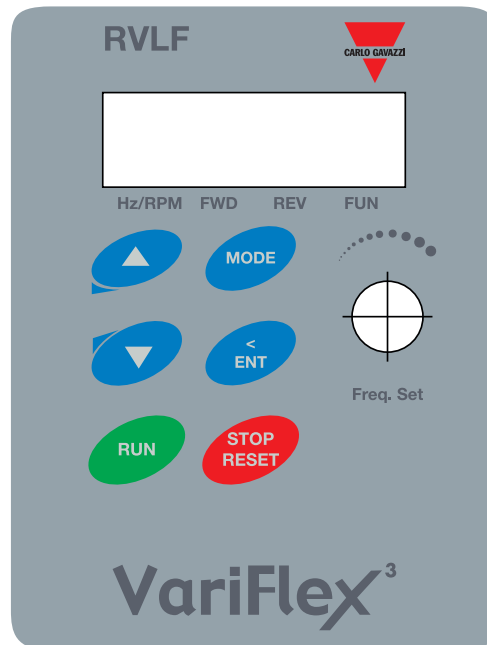

Type	Item	Function
Digital display & LEDs	Main digital displays	Frequency display, parameter, voltage, current, temperature, fault messages.
	LED status	Hz/RPM: ON when the frequency or line speed is displayed. OFF when the parameters are displayed. FWD: ON while the inverter is running forward. Flashes while stopped. REV: ON while the inverter is running reverse. Flashes while stopped. FUN: ON when the parameters are displayed. OFF when the frequency is displayed.
Variable resistor	FREQ SET	Used to set the frequency.
Keys On Keypad	RUN	RUN: Run at the set frequency.
	STOP/RESET (Dual function keys)	STOP: Decelerate or coast to stop. RESET: Use to reset alarms or resettable faults.
	▲	Increment parameter number and preset values.
	▼	Decrement parameter number and preset values.
	MODE	Switch between available displays.
	</ENTER (Dual function keys, a short press for left shift function, a long press for ENTER function)	“<” Left shift: Used while changing the parameters or parameter values ENTER: Used to display the preset value of parameters and for saving the changed parameter values.



## 4.2. Programmable Parameter Groups

---

Parameter group No.	Description
Group 00	Basic parameters
Group 01	V/F Pattern selections & setup
Group 02	Motor parameters
Group 03	Multi function digital inputs/outputs
Group 04	Analog signal inputs/analog output
Group 05	Preset frequency selections.
Group 06	Auto run (auto sequencer) function
Group 07	Start/Stop command setup
Group 08	Drive and motor protection
Group 09	Communication function setup
Group 10	PID function setup
Group 11	Performance control functions
Group 12	Digital display & monitor functions
Group 13	Inspection & maintenance function

Parameter notes for parameter groups	
*1	Parameter can be adjusted during running mode
*2	Cannot be modified in communication mode
*3	Does not change with factory reset
*4	Read only



Group 00 The basic parameters group					
No.	Description	Range	Factory setting	Unit	Note
00-00	Reserved				
00-01	Motor rotation	0: Forward 1: Reverse	0	-	*1
00-02	Main run source selection	0: Keypad	0	-	
		1: External Run/Stop control			
		2: Communication			
00-03	Alternative run source selection	0: Keypad	0	-	
		1: External Run/Stop control			
		2: Communication			
00-04	Operation modes for external terminals	0: Forward/Stop-Reverse/Stop	0	-	
		1: Run/Stop-Reverse/Forward			
		2: 3-Wire control Mode-Run/Stop			
00-05	Main frequency source selection	0: Keypad	0	-	
		1: Potentiometer on keypad			
		2: External AVI analog signal input			
		3: External ACI analog signal input			
		4: External Up/Down frequency control			
		5: Communication setting frequency			
6: PID output frequency					
00-06	Alternative frequency source selection	0: Keypad	4	-	
		1: Potentiometer on keypad			
		2: External AVI analog signal input			
		3: External ACI analog signal input			
		4: External Up/Down frequency control			
		5: Communication setting frequency			
6: PID output frequency.					
00-07	Main and alternative frequency command modes	0: Main or alternative frequency 1: Main frequency + alternative frequency	4	-	
00-08	Communication frequency command	0.00~650.00		Hz	*4
00-09	Frequency command save mode (communication mode)	0: Save the frequency before power down 1: Save the communication frequency	0	-	
00-10	Initial frequency selection (keypad mode)	0: By current frequency command	0	-	
		1: By 0 frequency command			
		2: By 00-11			
00-11	Initial frequency keypad mode	0.00~650.00	50.00/60.00	Hz	
00-12	Frequency upper limit	0.01~650.00	50.00/60.00	Hz	
00-13	Frequency lower limit	0.00~649.99	0.00	Hz	*1
00-14	Acceleration time 1	0.1~3600.0	10.0	sec	*1
00-15	Deceleration time 1	0.1~3600.0	10.0	sec	*1
00-16	Acceleration time 2	0.1~3600.0	10.0	sec	*1
00-17	Deceleration time 2	0.1~3600.0	10.0	sec	*1
00-18	Jog frequency	1.00~25.00	2.00	Hz	*1
00-19	Jog acceleration time	0.1~25.5	0.5	sec	*1
00-20	Jog deceleration time	0.1~25.5	0.5	sec	



Group 01 V/F Pattern selection & setup					
No.	Description	Range	Factory setting	Unit	Note
01-00	Volts/Hz patterns	1~7	1/4	-	
01-01	V/F max voltage	200V: 198.0~256.0 400V: 323.0~528.0	220.0/440.0	Vac	
01-02	Max frequency	0.20~650.00	50.00/60.00	Hz	
01-03	Max frequency voltage ratio	0.0~ 00.0	100.0	%	
01-04	Mid frequency 2	0.00~650.00	25.00/30.00	Hz	
01-05	Mid frequency voltage ratio 2	0.0~100.0	50.0	%	
01-06	Mid frequency 1	0.10~650.00	10.00/12.00	Hz	
01-07	Mid frequency voltage ratio 1	0.0~100.0	20.0	%	
01-08	Min frequency	0.10~650.00	0.50/0.60	Hz	
01-09	Min frequency voltage ratio	0.0~100.0	1.0	%	
01-10	Volts/Hz curve modification (torque boost) V/F start frequency	0~10.0	0.0	%	*1
01-11	V/F start frequency	0.00~10.00	0.0	Hz	

Group 02 Motor parameters					
No.	Description	Range	Factory setting	Unit	Note
02-00	Motor no load current	----		A	*3
02-01	Motor rated current (OL1)	----		A	
02-02	Motor rated slip compensation	0.0~100.0	0.0	%	*1
02-03	Motor rated speed	----		Rpm	
02-04	Motor rated voltage	----		Vac	*4



Group 03 Multi function Digital Inputs/Outputs					
No.	Description	Range	Factory setting	Unit	Note
03-00	Multifunction input term. S1	0: Forward/stop command or run/stop	0	-	
03-01	Multifunction input term. S2	1: Reverse/stop command or REV/WD	1	-	
03-02	Multifunction input term. S3	2: Preset speed 1 (5-02)	2	-	
03-03	Multifunction input term. S4	3: Preset speed 2 (5-03)	3	-	
03-04	Multifunction input term. S5	4: Preset speed 4 (5-05)	17	-	
		6: Jog forward command			
		7: Jog reverse command			
		8: Up command			
		9: Down command			
		10: Acc/dec 2			
		11: Acc/dec disabled			
		12: Main/alternative run command select			
		13: Main/alternative frequency command select			
		14: Rapid stop (decel to stop)			
15: Base block					
16: Disable PID function					
17: Reset					
18: Auto run mode enable					
03-05	Reserved				
03-06	Up/Down frequency band	0.00~5.00	0.00	Hz	
03-07	Up/Down frequency modes	0: When up/down is used, the preset frequency is held as the inverter stops, and the up/down function is disabled.	0	-	
		1: When up/down is used, the preset frequency is reset to 0 Hz as the inverter stops.			
		2: When up/down is used, the preset frequency is held as the inverter stops, and the up/down is available.			
03-08	S1~S5 scan confirmation	1~400. Number of scan cycles	20	1ms	
03-09	S1~S5 switch type select	xxxx0: S1 NO xxx1: S1 NC	00000	-	
		xxx0x: S2 NO xxx1x: S2 NC			
		xx0xx: S3 NO xx1xx: S3 NC			
		x0xxx: S4 NO x1xxx: S4 NC			
		0xxxx: S5 NO 1xxxx: S5 NC			
03-10	Reserved				
03-11	Output relay (RY1)	0: Run	0	-	
		1: Fault			
		2: Setting frequency reached			
		3: Frequency reached (3-13±3-14)			
		4: Output frequency detection 1 (> 3-13)			
		5: Output frequency detection 2 (< 3-13)			
		6: Auto-Restart			
		7: Momentary AC power loss			
		8: Rapid stop			
		9: Base block			
		10: Motor overload protection (OL1)			
		11: Drive overload protection (OL2)			
		12: Reserved			
		13: Output current reached			
14: Brake control					



Group 03 Multi function digital Inputs/Outputs					
No.	Description	Range	Factory setting	Unit	Note
03-12	Reserved				
03-13	Output frequency detection level (Hz)	0.00~650.00	0.00	Hz	*1
03-14	Frequency detection band	0.00~30.00	2.00	Hz	*1
03-15	Output current detection level	0.1~15.0	0.1	A	
03-16	Output current detection period	0.1~10.0	0.1	sec	
03-17	External brake release level	0.00~20.00	0.00	Hz	
03-18	External brake engage level	0.00~20.00	0.00	Hz	
03-19	Relay output function type	0: A (Normally open) 1: B (Normally close)	0	-	

“NO” indicates normally open, “NC” indicates normally closed.

Group 04 Analog signal inputs/Analogue output functions					
No.	Description	Range	Factory setting	Unit	Note
04-00	AVI/ACI analog input signal type select	AVI	ACI	0	-
		0:0~10V	0~20mA		
		1:0~10V	4~20mA		
		2:2~10V	0~20mA		
		3:2~10V	4~20mA		
04-01	AVI Signal verification scan rate	1~400	100	1ms	
04-02	AVI Gain	0~1000	100	%	*1
04-03	AVI Bias	0~100	0	%	*1
04-04	AVI Bias selection	0: Positive 1: Negative	0	-	*1
04-05	AVI Slope	0: Positive 1: Negative	0	-	*1
04-06	ACI Signal verification scan rate	1~400	100	1ms	
04-07	ACI Gain	0~1000	100	%	*1
04-08	ACI Bias	0~100	0	%	*1
04-09	ACI Bias selection	0: Positive 1: Negative	0	-	*1
04-10	ACI Slope	0: Positive 1: Negative	0	-	*1
04-11	Analog output mode (AO)	0: Output frequency 1: Frequency command 2: Output voltage 3: DC Bus voltage 4: Motor current	0	-	*1
04-12	Analog output AO gain (%)	0~1000	100	%	*1
04-13	Analog output AO bias (%)	0~1000	0	%	*1
04-14	AO Bias selection	0: Positive 1: Negative	0	-	*1
04-15	AO Slope	0: Positive 1: Negative	0	-	*1





Group 05 Preset frequency selections					
No.	Description	Range	Factory setting	Unit	Note
05-00	Preset speed control mode selection	0: Common Accel/Decel Accel/Decel 1 or 2 apply to all speeds	0	-	
		1: Individual Accel/Decel Accel/Decel 0-7 apply to the selected preset speeds (Acc0/Dec0~Acc7/Dec7)			
05-01	Preset speed 0 (Keypad Freq)	0.00~650.00	5.00	Hz	
05-02	Preset speed 1 (Hz)		5.00	Hz	*1
05-03	Preset speed 2 (Hz)		10.00	Hz	*1
05-04	Preset speed 3 (Hz)		20.00	Hz	*1
05-05	Preset speed 4 (Hz)		30.00	Hz	*1
05-06	Preset speed 5 (Hz)		40.00	Hz	*1
05-07	Preset speed 6 (Hz)		50.00	Hz	*1
05-08	Preset speed 7 (Hz)		50.00	Hz	*1
05-09 ~ 05-16	Reserved				
05-17	Preset speed 0- Acc time	0.1~3600.0	10.0	sec	*1
05-18	Preset speed 0- Dec time		10.0	sec	*1
05-19	Preset speed 1- Acc time		10.0	sec	*1
05-20	Preset speed 1- Dec time		10.0	sec	*1
05-21	Preset speed 2- Acc time		10.0	sec	*1
05-22	Preset speed 2- Dec time		10.0	sec	*1
05-23	Preset speed 3- Acc time		10.0	sec	*1
05-24	Preset speed 3- Dec time		10.0	sec	*1
05-25	Preset speed 4- Acc time		10.0	sec	*1
05-26	Preset speed 4- Dec time		10.0	sec	*1
05-27	Preset speed 5- Acc time		10.0	sec	*1
05-28	Preset speed 5- Dec time		10.0	sec	*1
05-29	Preset speed 6- Acc time		10.0	sec	*1
05-30	Preset speed 6- Dec time		10.0	sec	*1
05-31	Preset speed 7- Acc time		10.0	sec	*1
05-32	Preset speed 7- Dec time		10.0	sec	*1



Group 06 Auto run (Auto sequencer) function					
No.	Description	Range	Factory setting	Unit	Note
06-00	Auto Run (sequencer) mode selection	0: Disabled. 1: Single cycle. (Continues to run from the unfinished step if restarted). 2: Periodic cycle. (Continues to run from the unfinished step if restarted). 3: Single cycle, then holds the speed of final step to run. (Continues to run from the unfinished step if restarted). 4: Single cycle. (Starts a new cycle if restarted). 5: Periodic cycle. (Starts a new cycle if restarted). 6: Single cycle, then hold the speed of final step to run (Starts a new cycle if restarted).	0	-	
06-01	Auto Run mode frequency command 1	0.00~650.00	0.00	Hz	*1
06-02	Auto Run mode frequency command 2		0.00	Hz	*1
06-03	Auto Run mode frequency command 3		0.00	Hz	*1
06-04	Auto Run mode frequency command 4		0.00	Hz	*1
06-05	Auto Run mode frequency command 5		0.00	Hz	*1
06-06	Auto Run mode frequency command 6		0.00	Hz	*1
06-07	Auto Run mode frequency command 7		0.00	Hz	*1
06-08 ~ 06-15	Reserved				
06-16	Auto Run mode running time setting 0	0.0~3600.0	0.0	sec	
06-17	Auto Run mode running time setting 1		0.0	sec	
06-18	Auto Run mode running time setting 2		0.0	sec	
06-19	Auto Run mode running time setting 3		0.0	sec	
06-20	Auto Run mode running time setting 4		0.0	sec	
06-21	Auto Run Mode running time setting 5		0.0	sec	
06-22	Auto Run mode running time setting 6		0.0	sec	
06-23	Auto Run mode running time setting 7		0.0	sec	
06-24 ~ 06-31	Reserved				
06-32	Auto_ Run mode running direction 0	0: Stop 1: Forward	0	-	
06-33	Auto_ Run mode running direction 1	2: Reverse	0	-	



Group 06 Auto run (Auto sequencer) function					
No.	Description	Range	Factory setting	Unit	Note
06-34	Auto Run mode running direction 2	0: Stop 1: Forward 2: Reverse	0	-	
06-35	Auto Run mode running direction 3		0	-	
06-36	Auto Run mode running direction 4		0	-	
06-37	Auto Run mode running direction 5		0	-	
06-38	Auto Run mode running direction 6		0	-	
06-39	Auto Run mode running direction 7		0	-	

Group 07 Start/Stop command setup					
No.	Description	Range	Factory setting	Unit	Note
07-00	Momentary power loss and restart	0: Momentary power loss and restart disable 1: Momentary power loss and restart enable	0	sec	
07-01	Auto restart delay time	0.0~800.0	0.0	sec	
07-02	Number of auto restart attempts	0~10	0	-	
07-03	Reset mode setting	0: Enable reset only when run command is off 1: Enable reset when run command is on or off	0	-	
07-04	Direct running after power up	0: Enable direct run on power up 1: Disable direct run on power up	1	-	
07-05	Delay-ON timer	1.0~300.0	1.0	sec	
07-06	DC injection brake start frequency (Hz) in stop mode	0.10~10.00	1.5	Hz	
07-07	DC injection brake level (%) in stop mode	0~20	5	%	
07-08	DC injection brake time (seconds) in stop mode	0.0~25.5	0.5	sec	
07-09	Stopping method	0: Deceleration to stop 1: Coast to stop	0		



Group 08 Drive & Motor protection functions					
No.	Description	Range	Factory setting	Unit	Note
08-00	Trip prevention selection	xxxx0: Enable trip prevention during acceleration xxxx1: Disable trip prevention during acceleration xxx0x: Enable trip prevention during deceleration xxx1x: Disable trip prevention during deceleration xx0xx: Enable trip prevention in run mode xx1xx: Disable trip prevention in run mode x0xxx: Enable over voltage prevention in run mode x1xxx: Disable over voltage prevention in run mode	00000	-	
08-01	Trip prevention level during acceleration (%)	50~200	200	Inverter rated current 100%	
08-02	Trip prevention level during deceleration (%)	50~200	200		
08-03	Trip prevention level in run mode (%)	50~200	200		
08-04	Over voltage prevention level in run mode	350~390	380	VDC	
08-05	Electronic motor overload protection operation mode	0: Disable electronic motor overload protection 1: Enable electronic motor overload protection	1	-	
08-06	Operation after overload protection is activated	0: Coast-to-stop after overload protection is activated 1: Drive will not trip when overload protection is activated (OL1)	0	-	
08-07	Over heat protection (cooling fan control)	0: Auto (depends on temp.) 1: Operate while in RUN mode 2: Always run 3: Disabled	1	-	
08-08	AVR function (auto voltage regulation)	0: AVR function enable 1: AVR function disable 2: AVR function disable for stop 3: AVR function disable for deceleration 4: AVR function disable for stop and deceleration. 5: When VDC>(360V/740V), AVR function disable for stop and deceleration.	4	-	
08-09	Input phase lost protection	0: Disabled 1: Enabled	0	-	



Group 09 Communication function setup					
No.	Description	Range	Factory setting	Unit	Note
09-00	Assigned communication station number	1~32	1	-	*2*3
09-01	RTU code/ASCII code select	0: RTU code 1: ASCII code	0	-	*2*3
09-02	Baud rate setting (bps)	0: 4800 1: 9600 2: 19200 3: 38400	2	bps	*2*3
09-03	Stop bit selection	0: 1 Stop bit 1: 2 Stop bits	0	-	*2*3
09-04	Parity selection	0: Without parity 1: With even parity 2: With odd parity	0	-	*2*3
09-05	Data format selection	0: 8-bits data 1: 7-bits data	0	-	*2*3
09-06	Communication time-out detection time	0.0~25.5	0.0	sec	
09-07	Communication time-out operation selection	0: Deceleration to stop (00-15: deceleration time 1) 1: Coast to stop 2: Deceleration to stop (00-17: deceleration time 2) 3: Continue operating	0	-	
09-08	Error 6 verification time	1~20	3		
09-09	Drive transmit delay time (ms)	5~65	5	ms	



Group 10 PID function Setup					
No.	Description	Range	Factory setting	Unit	Note
10-00	PID target value selection (when 00-05\00-06=6 ,this function is enabled)	0: Potentiometer on keypad 1: Analog signal input. (AVI) 2: Analog signal input. (ACI) 3: Frequency set by communication 4: KeyPad frequency parameter -02	1	-	*1
10-01	PID feedback value selection	0: Potentiometer on keypad 1: Analog signal input. (AVI) 2: Analog signal input. (ACI) 3: Frequency set by communication	2	-	*1
10-02	PID target (keypad input)	0.0~100.0	50.0	%	*1
10-03	PID mode selection	0: Disabled 1: Deviation D control. FWD characteristic. 2: Feedback D control FWD characteristic. 3: Deviation D control reverse characteristic. 4: Feedback D control reverse characteristic.	0	-	
10-04	Feedback gain coefficient	0.00~10.00	1.00	%	*1
10-05	Proportional gain	0.0~10.0	1.0	%	*1
10-06	Integral time	0.0~100.0	10.0	sec	*1
10-07	Derivative time	0.00~10.00	0.00	sec	*1
10-08	PID offset	0: Positive 1: Negative	0	-	*1
10-09	PID offset adjust	0~109	0	%	*1
10-10	PID output lag filter time	0.0~2.5	0.0	sec	*1
10-11	Feedback loss detection mode	0: Disabled 1: Enabled - drive continues to operate after feedback loss 2: Enabled - drive "STOPS" after feedback loss			
10-12	Feedback loss detection leve	0~100	0	%	
10-13	Feedback loss detection delay time	0.0~25.5	1.0	sec	
10-14	Integration limit value	0~109	100	%	*1
10-15	Integral value resets to zero when feedback signal equals the target value	0: Disabled 1: 1 Second 30: 30 Seconds (0 ~ 30)	0	-	
10-16	Allowable integration error margin (units) (1unit = 1/8192)	0~100	0	-	
10-17	PID sleep frequency level	0.00~650.00	0.00	Hz	
10-18	PID sleep function delay time	0.0~25.5	0.0	sec	
10-19	PID wake up frequency level	0.00~650.00	0.00	Hz	
10-20	PID wake up function delay time	0.0~25.5	0.0	sec	
10-21	Max PID feedback setting	0~999	100	-	*1
10-22	Min PID feedback setting	0~999	0	-	*1



Group 11 Performance control functions					
No.	Description	Range	Factory setting	Unit	Note
11-00	Reverse operation control	0: Reverse command is enabled 1: Reverse command is disabled	0	-	
11-01	Carrier frequency (kHz)	1~16	5	KHz	
11-02	Carrier mode selection	0: Mode 0, 3 phase PWM modulation 1: Mode 1, 2 phase PWM modulation 2: Mode 2, 2 phase random PWM modulation	0	-	
11-03	Carrier frequency reduction by temperature rise	0: Disabled 1: Enabled	0	-	
11-04	S-Curve acc 1	0.0~4.0	0.00	sec	
11-05	S-Curve acc 2	0.0~4.0	0.00	sec	
11-06	S-Curve dec 3	0.0~4.0	0.00	sec	
11-07	S-Curve dec 4	0.0~4.0	0.00	sec	
11-08	Skip frequency 1	0.00~650.00	0.00	Hz	*1
11-09	Skip frequency 2	0.00~650.00	0.00	Hz	*1
11-10	Skip frequency 3	0.00~650.00	0.00	Hz	*1
11-11	Skip frequency bandwidth (±)	0.00~30.00	0.00	Hz	*1

Group 12 Digital Display & Monitor functions					
No.	Description	Range	Factory setting	Unit	Note
12-00	Extended display mode	00000~77777. Each digit can be set to 0 to 7 0: Default display (frequency&parameters) 1: Output current 2: Output voltage 3: DC voltage 4: Temperature 5: PID feedback 6: Analog signal input. (AVI) 7: Analog signal input. (ACI)	00000	-	*1
12-01	PID feedback display format	0: Integer (xxx) 1: One decimal place (xx.x) 2: Two decimal places (x.xx)	0	-	*1
12-02	PID feedback display unit setting	0: xxx-- 1: xxxpb (pressure) 2: xxxfl (flow)	0	-	*1
12-03	Custom units (line speed) value	0~65535	1500/1800	RPM	*1
12-04	Custom units (line speed) display mode	0: Drive output frequency is displayed 1: Line speed. Integer. (xxxxx) 2: Line Speed. One Decimal place (xxxx.x) 3: Line speed. Two decimal places (xxx.xx) 4: Line speed. Three decimal places (xx.xxx)	0	-	*1



Group 12 Digital display & monitor functions					
No.	Description	Range	Factory setting	Unit	Note
12-05	Inputs and output logic status display (S1 to S5) & RY1		-----	-	*4

Group 13 Inspection & maintenance functions					
No.	Description	Range	Factory setting	Unit	Note
13-00	Drive horsepower code	----	-	-	*3
13-01	Software version	----	-	-	*3*4
13-02	Fault log (last 3 faults)	----	-	-	*3*4
13-03	Accumulated operation time1 1	0~23	-	Hour	*3
13-04	Accumulated operation time1 2	0~65535	----	Day	*3
13-05	Accumulated operation time mode	0: Time under power 1: Run mode time only	0	-	*3
13-06	Parameter lock	0: Enable all functions 1: Preset speeds 05-01~05-08 cannot be changed 2: All functions cannot be changed except for preset speeds 05-01~05-08 3: Disable all function	0	-	
13-07	Parameter lock code	00000~65535	00000	-	
13-08	Reset drive to factory settings	1150: Reset to factory setting. 50Hz system. 1160: Reset to factory setting. 60Hz system.	00000	-	





## 5. Troubleshooting and Maintenance

### 5.1. Error Display and Corrective Action

#### 5.1.1. Manual Reset and Auto-Reset

Faults which can not be recovered manually			
Display	Content	Cause	Corrective action
-oV-	Voltage too high when stopped	Detection circuit malfunction	Consult with the supplier
-LV-	Voltage too low when stopped	1. Power voltage too low 2. Pre-charge resistor or fuse burnt out. 3. Detection circuit malfunction	1. Check if the power voltage is correct 2. Failed resistor or fuse 3. Consult with the supplier
-oH-	The inverter is overheated when stopped	1. Detection circuit malfunction 2. Ambient temperature too high or bad ventilation	Improve the ventilation conditions, if no result then replace the inverter
OH-C	The inverter is overheated during running	1. IGBT temperature is too high or bad ventilation 2. Temperature sensor error or circuit malfunctions	1. Reduce carrier frequency 2. Improve the ventilation conditions, if no result then replace the inverter
CtEr	Current s.ensor detection error	Current sensor error or circuit malfunction	Consult with the supplier
EPr	EEPROM problem	Faulty EEPROM	Consult with the supplier
Cot	Communication error	Communications disruption	Check the wiring



Faults which can not be recovered manually			
Display	Content	Cause	Corrective action
oC-A	Over current at acceleration	1. Acceleration time too short 2. The capacity of the motor exceeds the capacity of the inverter 3. Short circuit between the motor coil and the case 4. Short circuit between motor wiring and ground 5. IGBT module damaged	1. Set a longer acceleration time 2. Replace inverter with one that has the same rating as that of the motor 3. Check the motor 4. Check the wiring 5. Consult with the supplier
oC-C	Over current at fixed speed	1. Transient load change 2. Transient power change	1. Increase the capacity of the inverter 2. Install inductor on the power supply input side
oC-d	Over current at deceleration	The preset deceleration time is too short.	Set a longer deceleration time
oC-S	Over current at start	1. Short circuit between the motor coil and the case 2. Short circuit between motor coil and ground 3. IGBT module damaged	1. Inspect the motor 2. Inspect the wiring 3. Consult with the supplier
oV-C	Excessive voltage during operation/deceleration	1. Deceleration time setting too short or excessive load inertia 2. Power voltage varies widely (fluctuates)	1. Set a longer deceleration time 2. Consider use of a brake resistor and/or brake module (in case of 400V models) 3. Consider use of a reactor at the power input side
PF	Input phase loss	Abnormal fluctuations in the main circuit voltage	1. Check the main circuit power supply wiring. 2. Check the power supply voltage



Faults which can not be recovered manually			
Display	Content	Cause	Corrective action
oC	Over-current during stop	Detection circuit malfunction	Consult with the supplier
oL1	Motor overload	Loading too large	Consider increasing the motor capacity
oL2	Inverter overload	Excessive load	Consider increasing the inverter capacity
LV-C	Voltage too low during operation	1. Power voltage too low 2. Power voltage varies widely (fluctuates)	1. Improve power quality 2. Consider adding a reactor at the power input side



### 5.1.2. Keypad Operation Error Instruction

Faults which can not be recovered manually			
Display	Content	Cause	Corrective action
LoC	1. Parameter already locked 2. Motor direction locked 3. Parameter password (13-07) enabled	1. Attempt to modify frequency parameter while 13-06>0. 2. Attempt to reverse direction when 11- 00=1. 3. Parameter (13 - 07) enabled, set the correct password will show LOC.	1. Adjust 13-06 2. Adjust 11-00
LoC			
Err1	Keypad operation error	1. Press Δ or ∇ while 00 - 05 / 00-06 > 0 or running at preset speed. 2. Attempt to modify the parameter. Can not be modified during operation (refer to the parameter list)	1. The Δ or ∇ is available for modifying the parameter only when 00-05/00-06=0 2. Modify the parameter in STOP mode.
Err1			
Err2	Parameter setting error	1. 00-13 is within the range of (11-08 ±11-11) or (11-09 ±11-11) or (11-10±11-11) 2. 00- 12≤00-13 3. Set 00-05 and 00-06 to be same value 4. When 01-00 7, modify parameter 01-01~01-09	1. Modify 11-08~11-10 or 11-11 Set 00-12>00-13
Err2			
Err5	Modification of parameter is not available in communication	1. Control command sent during communication. 2. Attempt to modify the function 09-02~09-05 during communication	1. Issue enable command before communication 2. Set parameters 09-02~09-05 function before communication
Err5			
Err6	Communication failed	1. Wiring error 2. Communication parameter setting error. 3. Incorrect communication protocol	1. Check hardware and wiring 2. Check functions (09-00~09- 05).
Err6			
Err7	Parameter conflict	1. Attempt to modify the function 13-00/13-08. 2. Voltage and current detection circuit is abnormal.	If reset is not possible, please consult with the supplier.
Err7			



### 5.1.3. Special Conditions

Faults which can not be recovered manually		
Display	Fault	Description
StP0	Zero speed at stop	Occurs when preset frequency <0.1Hz
STP0		
StP1	Fail to start directly on power up.	1. If the inverter is set for external terminal control mode (00-02/00-03=1) and direct start is disabled (07-04=1) 2. The inverter cannot be started and will flash STP1. 3. The run input is active at power-up, refer to descriptions of (07-04).
STP1		
StP2	Keypad stop operated when inverter in external control mode.	1. If the Stop key is pressed while the inverter is set to external control mode (00-02/00-03=1) then 'STP2' flashes after stop. 2. Release and re-activate the run contact to restart the inverter.
STP2		
E.S.	External rapid stop	When external rapid stop input is activated the inverter will decelerate to stop and the display will flash with E.S. message.
ES.		
b.b.	External base block	When external base block input is activated the inverter stops immediately and then the display will flash with b.b. message.
bb.		
PdEr	PID feedback loss	PID feedback loss is detected.
PdEr		



## 5.2. General Troubleshooting

Status	Checking point	Remedy
<b>Motor runs in wrong direction</b>	Is the wiring for the output terminals correct?	Wiring must match U, V, and W terminals of the motor.
	Is the wiring for forward and reverse signals correct?	Check for correct wiring.
<b>The motor speed can not be regulated</b>	Is the wiring for the analog frequency inputs correct?	Check for correct wiring.
	Is the setting of operation mode correct?	Check the frequency source set in parameters 00-05/00-06.
	Is the load too excessive?	Reduce the load.
<b>Motor running speed too high or too low</b>	Check the motor specifications (poles, voltage...) correct?	Confirm the motor specifications.
	Is the gear ratio correct?	Confirm the gear ratio.
	Is the setting of the highest output frequency correct?	Confirm the highest output frequency
<b>Motor speed varies unusually</b>	Is the load too excessive?	1. Minimize the variation of the load. 2. Consider increasing the capacities of the inverter and the motor.
	Does the load vary excessively?	Consider adding an AC reactor at the power input side if using single-phase power.
	Is the input power unstable or is there a phase loss?	2. Check wiring if using three-phase power
<b>Motor can not run</b>	Is the power connected to the correct L1, L2, and L3 terminals? is the charging indicator lit ?	1. Is the power applied? 2. Turn the power OFF and then ON again. 3. Make sure the power voltage is correct. 4. Make sure screws are secured firmly.
	Is there voltage across the output terminals T1, T2, and T3?	Turn the power OFF and then ON again.
	Is overload causing the motor to stall?	Reduce the load so the motor will run.
	Are there any abnormalities in the inverter?	See error descriptions to check wiring and correct if necessary.
	Is there a forward or reverse run command?	
	Has the analog frequency signal been input?	1. Is analog frequency input signal wiring correct? 2. Is voltage of frequency input correct?
	Is the operation mode setting correct?	Operate through the digital keypad



## OUR SALES NETWORK IN EUROPE

**AUSTRIA** - Carlo Gavazzi GmbH  
Ketzergasse 374, A-1230 Wien  
Tel: +43 1 888 4112  
Fax: +43 1 889 10 53  
office@carlogavazzi.at

**BELGIUM** - Carlo Gavazzi NV/SA  
Mechelsesteenweg 311, B-1800 Vilvoorde  
Tel: +32 2 257 4120  
Fax: +32 2 257 41 25  
sales@carlogavazzi.be

**DENMARK** - Carlo Gavazzi Handel A/S  
Over Hadstenvej 40, DK-8370 Hadsten  
Tel: +45 89 60 6100  
Fax: +45 86 98 15 30  
handel@gavazzi.dk

**FINLAND** - Carlo Gavazzi OY AB  
Petaksentie 2-4, FI-00630 Helsinki  
Tel: +358 9 756 2000  
Fax: +358 9 756 20010  
myynti@gavazzi.fi

**FRANCE** - Carlo Gavazzi Sarl  
Zac de Paris Nord II, 69, rue de la Belle  
Etoile, F-95956 Roissy CDG Cedex  
Tel: +33 1 49 38 98 60  
Fax: +33 1 48 63 27 43  
french.team@carlogavazzi.fr

**GERMANY** - Carlo Gavazzi GmbH  
Pfnorstr. 10-14  
D-64293 Darmstadt  
Tel: +49 6151 81000  
Fax: +49 6151 81 00 40  
info@gavazzi.de

**GREAT BRITAIN** - Carlo Gavazzi UK Ltd  
4.4 Frimley Business Park,  
Frimley, Camberley, Surrey GU16 7SG  
Tel: +44 1 276 854 110  
Fax: +44 1 276 682 140  
sales@carlogavazzi.co.uk

**ITALY** - Carlo Gavazzi SpA  
Via Milano 13, I-20020 Lainate  
Tel: +39 02 931 761  
Fax: +39 02 931 763 01  
info@gavazziacbu.it

**NETHERLANDS** - Carlo Gavazzi BV  
Wijkermeerweg 23,  
NL-1948 NT Beverwijk  
Tel: +31 251 22 9345  
Fax: +31 251 22 60 55  
info@carlogavazzi.nl

**NORWAY** - Carlo Gavazzi AS  
Melkeveien 13, N-3919 Porsgrunn  
Tel: +47 35 93 0800  
Fax: +47 35 93 08 01  
post@gavazzi.no

**PORTUGAL** - Carlo Gavazzi Lda  
Rua dos Jerónimos 38-B,  
P-1400-212 Lisboa  
Tel: +351 21 361 7060  
Fax: +351 21 362 13 73  
carlogavazzi@carlogavazzi.pt

**SPAIN** - Carlo Gavazzi SA  
Avda. Iparraguirre, 80-82,  
E-48940 Leioa (Bizkaia)  
Tel: +34 94 480 4037  
Fax: +34 94 431 6081  
gavazzi@gavazzi.es

**SWEDEN** - Carlo Gavazzi AB  
V:a Kyrkogatan 1,  
S-652 24 Karlstad  
Tel: +46 54 85 1125  
Fax: +46 54 85 11 77  
info@carlogavazzi.se

**SWITZERLAND** - Carlo Gavazzi AG  
Verkauf Schweiz/Vente Suisse  
Sumpfstrasse 3,  
CH-6312 Steinhausen  
Tel: +41 41 747 4535  
Fax: +41 41 740 45 40  
info@carlogavazzi.ch

## OUR SALES NETWORK IN THE AMERICAS

**USA** - Carlo Gavazzi Inc.  
750 Hastings Lane,  
Buffalo Grove, IL 60089, USA  
Tel: +1 847 465 6100  
Fax: +1 847 465 7373  
sales@carlogavazzi.com

**CANADA** - Carlo Gavazzi Inc.  
2660 Meadowvale Boulevard,  
Mississauga, ON L5N 6M6, Canada  
Tel: +1 905 542 0979  
Fax: +1 905 542 22 48  
gavazzi@carlogavazzi.com

**MEXICO** - Carlo Gavazzi Mexico S.A. de C.V.  
Calle La Montaña no. 28, Fracc. Los Pastores  
Naucalpan de Juárez, EDOMEX CP 53340  
Tel & Fax: +52.55.5373.7042  
mexicosales@carlogavazzi.com

**BRAZIL** - Carlo Gavazzi Automação Ltda.  
Av. Francisco Matarazzo, 1752  
Conj 2108 - Barra Funda - São Paulo /SP  
CEP 01401-000  
Tel: +55 11 3052 0832  
Fax: +55 11 3057 1753  
info@carlogavazzi.com.br

## OUR SALES NETWORK IN ASIA AND PACIFIC

**SINGAPORE** - Carlo Gavazzi Automation  
Singapore Pte. Ltd.  
61 Tai Seng Avenue  
#05-06 UE Print Media Hub  
Singapore 534167  
Tel: +65 67 466 990  
Fax: +65 67 461 980  
info@carlogavazzi.com.sg

**MALAYSIA** - Carlo Gavazzi Automation  
(M) SDN. BHD.  
D12-06-G, Block D12,  
Pusat Perdagangan Dana 1,  
Jalan PJU 1A/46, 47301 Petaling Jaya,  
Selangor, Malaysia.  
Tel: +60 3 7842 7299  
Fax: +60 3 7842 7399  
sales@gavazzi-asia.com

**CHINA** - Carlo Gavazzi Automation  
(China) Co. Ltd.  
Unit 2308, 23/F.,  
News Building, Block 1, 1002  
Middle Shennan Zhong Road,  
Shenzhen, China  
Tel: +86 755 83699500  
Fax: +86 755 83699300  
sales@carlogavazzi.cn

**HONG KONG** - Carlo Gavazzi  
Automation Hong Kong Ltd.  
Unit 3 12/F Crown Industrial Bldg.,  
106 How Ming St., Kwun Tong,  
Kowloon, Hong Kong  
Tel: +852 23041228  
Fax: +852 23443689

## OUR COMPETENCE CENTRES AND PRODUCTION SITES

**DENMARK** - Carlo Gavazzi Industri A/S  
Hadsten

**MALTA** - Carlo Gavazzi Ltd  
Zejtun

**ITALY** - Carlo Gavazzi Controls SpA  
Belluno

**LITHUANIA** - Uab Carlo Gavazzi  
Industri Kaunas

**CHINA** - Carlo Gavazzi Automation  
(Kunshan) Co., Ltd.  
Kunshan

## HEADQUARTERS

Carlo Gavazzi Automation SpA  
Via Milano, 13 - I-20020  
Lainate (MI) - **ITALY**  
Tel: +39 02 931 761  
info@gavazziautomation.com



**CARLO GAVAZZI**  
Automation Components

*Energy to Components!*

www.gavazziautomation.com

