

Safety Light Curtain with infrared beams SC2 type
Instruction manual

Sense



ORIGINAL INSTRUCTIONS (ref. 2006/42/EC)

CARLO GAVAZZI LOGISTICS S.p.A.
Headquarter: Via Milano 13, I-20020 Lainate (MI)
Tel.: +39 02 93176.1, Fax +39 02 9176.403
Internet: <http://www.gavazziautomation.com>

SC2 Instruction Manual
Ed. 03/2013

All brand and product names mentioned herein are for identification purposes only and may be trademarks or registered trademarks of their respective owners.

Carlo Gavazzi shall not be liable for technical or editorial errors or omissions contained herein, not for incidental or consequential damages resulting from the use of this material.



CARLO GAVAZZI
Automation Components

DECLARATION OF CONFORMITY

CARLO GAVAZZI

CARLO GAVAZZI LOGISTICS S.p.A.
Headquarter: Via Milano 13, I-20020 Lainate (MI)
Tel.: +39 02 93176.1, Fax +39 02 9176.403
Internet: <http://www.gavazziautomation.com>

declars that the

SC2
SAFETY LIGHT CURTAINS - ELECTRO-SENSITIVE PROTECTIVE EQUIPMENT
(Type 2 ESPE)

and all its models are in conformity with the requirements of the European Council Directives listed below:

2006 / 42 / EC Machinery Directive
2004 / 108 / EC EMC Directive
2006 / 95 / EC Low Voltage Directive

This Declaration is based upon compliance of the products to the following standards:





EN 61496-1: 2004	Safety of machinery - Electro-Sensitive protective equipment. Part 1: General requirements and tests.
IEC 61496-2: 2006	Safety of machinery - Electro-Sensitive protective equipment. Part 2: Particular requirements for equipment using active opto-electronic protective devices (AOPDs).
IEC 61508-1/3/4: 1998	Functional safety of electrical/electronic/programmable electronic.
IEC 61508-2: 2000	Safety-related systems.
EN 954-1: 1996	Safety of machinery - Safety related parts of control system.
EN ISO 13849-1: 2008	Safety of machinery - Safety related parts of control system. Part 1: General principles for design.
EN 62061: 2005	Safety of machinery - Functional safety of safety-related electrical, electronic and programmable electronic control system.
EN 50178: 1997	Electronic equipment for use in power installations.
EN 61000-6-2: 2005	Electromagnetic standards - Immunity for industrial environments.
EN 55022 (Class A ITE): 2010	Limits and methods of measurements of radio disturbance of information technology equipment.

Conformity as been certified by the following Notified/Competent body (identification N° 0123): TÜV SÜD Rail GmbH, Ridlerstrasse, 57 - D80339 München.

Carlo Gavazzi Logistics have a quality system certified by the EQA, Nr. QA130463, as per ISO 9001 and have therefore observed the regulations foreseen during development and manufacturing.

Lainate / September 30th 2013

Vittorio Rossi
Carlo Gavazzi Logistics S.p.A.
Managing director



Index

1. GENERAL INFORMATION	1
1.1. General description of the safety light curtains	4
1.1.1. Package contents	5
1.2. New features compared to the SB2 Series	6
1.3. How to choose the device	7
1.3.1. Resolution	7
1.3.2. Controlled height	8
1.3.3. Minimum installation distance	9
1.4. Typical applications	12
1.5. Safety information	14
2. INSTALLATION MODE	15
2.1. Precautions to be observed for the choice and installation of the device	15
2.2. General information on device positioning	16
2.2.1. Minimum installation distance	17
2.2.2. Minimum distance from reflecting surfaces	18
2.2.3. Emitter and receiver orientation	20
2.2.4. Installation of several adjacent safety light curtains	21
2.2.5. Use of deviating mirrors	22
2.2.6. Controls after first installation	23
3. MECHANICAL MOUNTING	24
4. ELECTRICAL CONNECTIONS	27
4.1. Notes on connections	28
4.2. Earth connection	30
5. ALIGNMENT PROCEDURE	31
5.1. Correct alignment procedure	33
6. FUNCTIONING MODE	34
6.1. Reset mode	34
6.2. Test function	34
6.3. Reset function	34
7. DIAGNOSTIC FUNCTIONS	35
7.1. User interface	35
7.2. Diagnostic messages	36
8. PERIODICAL CHECKS	37
8.1. General information and useful data	38
8.2. Warranty	38
9. DEVICE MAINTENANCE	39
9.1. Product disposal	39



10. TECHNICAL DATA	40
11. LIST OF AVAILABLE MODELS	41
12. OVERALL DIMENSIONS	43
13. ACCESSORIES	44
13.1. Angled fixing bracket	44
13.2. Test pieces	46
13.3. Connection cables	46
14. GLOSSARY	47



1. General Information

1.1. General Description of the Safety Light Curtains

The safety light curtains of the SC2 series are optoelectronic multibeam devices that are used to protect working areas that, in presence of machines, robots, and automatic systems in general, can become dangerous for operators that can get in touch, even accidentally, with moving parts. The light curtains of the SC2 series are Type 2 intrinsic safety systems used as accident-prevention protection devices and are manufactured in accordance with the international Standards in force for safety, in particular:

- | | |
|------------------------------|--|
| CEI IEC 61496-1: 2004 | Safety of machinery: electro-sensitive protective equipment. Part 1: General prescriptions and tests. |
| CEI IEC 61496-2: 2006 | Safety of machinery: electro-sensitive protective equipment. Particular requirements for equipment using active optoelectronic protective devices. |

The device, consisting of one emitter and one receiver housed inside strong aluminium profiles, generates infrared beams that detect any opaque object positioned within the light curtain detection field. The emitter and the receiver are equipped with the command and control functions. The connections are made through a M12 connector located in the lower side of the profile. The synchronisation between the emitter and the receiver takes place optically, i.e. no electrical connection between the two units is required. The microprocessor guarantees the check and the management of the beams that are sent and received through the units. The microprocessor – through some LEDs – informs the operator about the general conditions of the safety light curtain (see section 7 “Diagnostic functions”). The device consists in 2 units that, according to the model, are composed by one or several emitting and receiving modules. The receiver checks the control operations and safety actions.

During installation, two yellow LEDs facilitate the alignment of both units (see section 5 “Alignment procedure”). As soon as an object, a limb or the operator’s body accidentally interrupts one or some of the infrared beams sent by the emitter, the receiver immediately opens the OSSD outputs and blocks the MPCE machine (if correctly connected to the OSSD).

Some parts or sections of this manual containing important information for the operator are preceded by a note.

Notes and detailed descriptions about particular characteristics of the safety devices in order to better explain their functioning. Special instructions regarding the installation process.



⚠ The information provided in the paragraphs following this symbol is very important for safety and may prevent accidents. Always read this information accurately and carefully follow the advice to the letter.

This manual contains all the information necessary for the selection and operation of the safety devices. However, specialised knowledge not included in this technical description is required for the planning and implementation of a safety light curtain on a power-driven machine. As the required knowledge may not be completely included in this manual, we suggest the customer to contact Carlo Gavazzi Technical Service for any necessary information relative to the functioning of the SC2 light curtains and the safety rules that regulate the correct installation (see section 8 "Periodical checks").



1.1.1. Package Contents

Package contains the following objects:

- Receiver (RX)
- Emitter (TX)
- Quick Guide for first installation
- CD with user manual and other documents
- Checklist and periodical maintenance schedule
- 4 angled fixing brackets and specific fasteners
- 2 angled fixing brackets for models with heights included between 1200 and 1500 mm

1.2. New Features Compared to the Former SB2 Series

The SC2 safety light curtains, compared to the SB2 series, present the following new features:

- Increased operating distance
- Range enlargement with 300 to 1500 mm controlled heights
- Reduced response times
- New fastening system with rotating brackets
- New mechanical profile compatible with SB accessories
- Different positioning of synchronisation optics (the first one from the reference line)
- Different mechanical mounting

1.3. How to Choose the Device

1.3. How to choose the device

There are at least three different main characteristics that should be considered when choosing a safety light curtain, after having evaluated the risk assessment:

1.3.1. Resolution

The resolution of the device is the minimum dimension that an opaque object must have in order to obscure at least one of the beams that constitute the sensitive area.

The resolution strictly depends on the part of the body to be protected

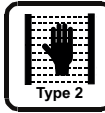
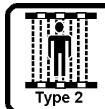
R = 30 mm	Hand protection	
R = 90mm	Presence control	

As shown in Fig.1, the resolution only depends on the geometrical characteristics of the lenses, diameter and distance between centres, and is independent from any environmental and operating conditions of the safety light curtain.

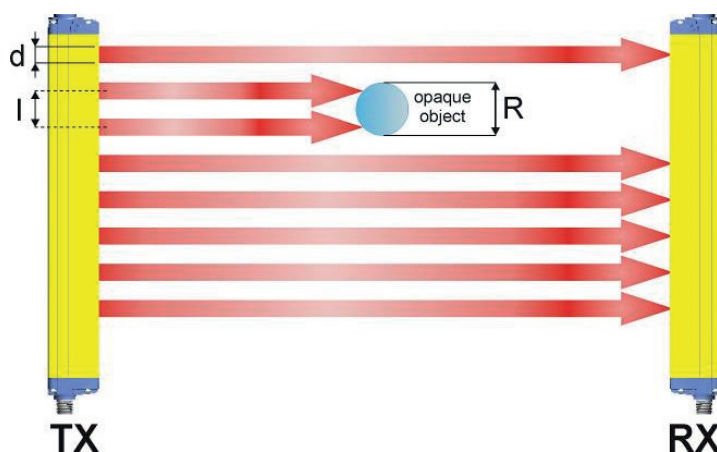

Fig.1

The resolution value is obtained applying the following formula:

$$R = l + d$$

where:

l = Distance between two adjacent optics

d = Lens diameter

1.3.2. Controlled Height

The controlled height is the height protected by the safety light curtain (H_p)

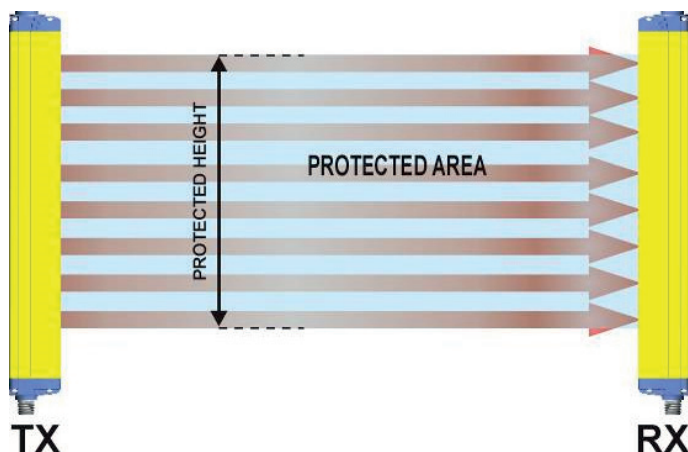
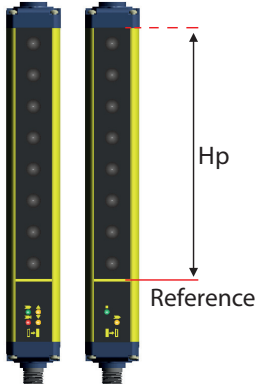
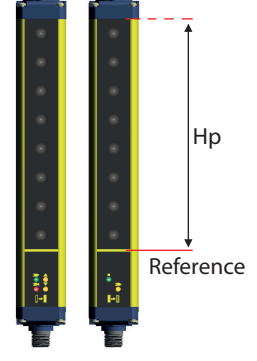

Fig.2

The SC2 controlled height is delimited by the yellow line pad-printed on the front glass and by the dimensions listed in the table:

	Model	Controlled height H_p (mm)
	SC2-AR-30-150-D19	150
	SC2-AR-30-300-D19	300
	SC2-AR-30-450-D19	450
	SC2-AR-30-600-D19	600
	SC2-AR-30-750-D19	750
	SC2-AR-30-900-D19	900
	SC2-AR-30-1050-D19	1050
	SC2-AR-30-1200-D19	1200
	SC2-AR-30-1350-D19	1350
SC2-AR-30-1500-D19	1500	

	Model	Controlled height H_p (mm)
	SC2-AR-90-300-D19	300
	SC2-AR-90-450-D19	450
	SC2-AR-90-600-D19	600
	SC2-AR-90-750-D19	750
	SC2-AR-90-900-D19	900
	SC2-AR-90-1050-D19	1050
	SC2-AR-90-1200-D19	1200
	SC2-AR-90-1350-D19	1350
SC2-AR-90-1500-D19	1500	

1.3.3. Minimum Installation Distance

The safety device must be positioned at a specific safety distance (Fig. 3). This distance must ensure that the dangerous area cannot be reached before the dangerous motion of the machine has been stopped by the ESPE (Electro Sensitive Protective Equipment).

The safety distance depends on 4 factors, according to the EN-999 Standard:

- Response time of the ESPE (the time between the effective beam interruption and the opening of the OSSD contacts).
- Machine stopping time (the time between the effective opening of the contacts of the ESPE and the real stop of the dangerous motion of the machine).
- ESPE resolution.
- Approaching speed of the object to be detected.

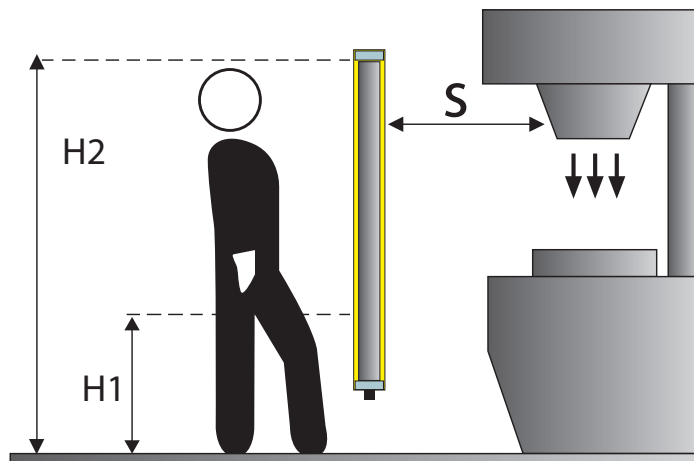

Fig.3

The following formula is used for the calculation of the safety distance:

$$S = K (t_1 + t_2) + C$$

where:

S = Minimum safety distance in mm.

K = Speed of the object, limb or body approaching the dangerous area in mm/sec.

t_1 = Response time of the ESPE in seconds (see section 9 "Technical data")

t_2 = Machine stopping time in seconds.

d = Resolution of the system.

C = Additional distance based on the possibility to insert the body or one of body parts inside the dangerous area before the protective device trips.

C = 8 (d - 14) for devices with resolution ≤ 40 mm

C = 850 mm for devices with resolution ≥ 40 mm.

NOTE: K value is:

2000 mm/s if the calculated value of S is ≤ 500 mm

1600 mm/s if the calculated value of S is > 500 mm



When devices with >40 mm resolution are used, the height of the top beam has to be ≥ 900 mm (H2) from machine supporting base while the height of the bottom beam has to be ≤ 300 mm (H1). If the safety light curtain must be mounted in a horizontal position (Fig.4), the distance between the dangerous area and the most distant optical beam must be equal to the value calculated using the following formula:

$$S = 1600 \text{ mm/s } (t_1 + t_2) + 1200 - 0.4 H$$

where:

S = Minimum safety distance in mm.

t_1 = Response time of the ESPE in seconds (see section 9 "Technical data")

t_2 = Machine stopping time in seconds.

H = Beam height from ground; this height must always be less than 1,000 mm.

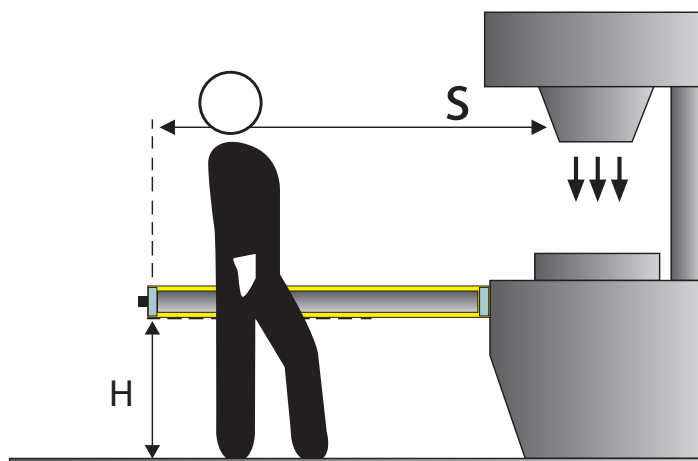

Fig.4



Practical examples:

Let's suppose we have a light curtain with height = 600 mm

1) To calculate the distance of the device from the ESPE, in a vertical position, the following formula is used:

$$S = K * T + C$$

where:

$$T = t_1 + t_2$$

t_1 = ESPE response time relay release time (max 80 ms)

t_2 = Machine total stopping time.

$C = 8 * (d - 14)$ for devices with resolution ≤ 40 mm

$C = 850$ for devices with resolution > 40 mm

d = Resolution of the system.

In all cases, if $K = 2000$ mm/sec then S will be > 500 mm.

Distance will have then to be recalculated using $K = 1600$ mm/sec.

	SC2-AR-30-600-D19	SC2-AR-90-600-D19
T	0.398 sec	0.391 sec
C	128 mm	850 mm
S	764.8 mm	1475.6 mm

2) To calculate the distance of the device from the ESPE, in a horizontal position, the following formula is used:

$$S = 1600 * T + 1200 - 0.4 * H$$

where:

H = Beam min. height from ground $15 * (d - 50)$

D = Resolution

		SC2-AR-90-600-D19
T	-	0.391 sec
H	-	600 mm
S	-	1585.6 mm

⚠WARNING: the reference standard is EN-999 “Machine safety - the positioning of the protective device based on the approaching speed of the human body”. This information is just an indication and a kind of summary. For safety distance correct calculation, it is compulsory to refer to the whole EN999 standard.



1.4. Typical Application

The safety light curtains of the SC2 series are used in all automation fields where the control and protection of the access to dangerous areas are necessary.

In particular, they are used to stop the moving of mechanical parts in:

- Automatic machines;
- Machines for packaging, material handling, storing;
- Weaving machines, wood working machines, ceramic working machines;
- Automatic and semiautomatic assembly lines;
- Automatic warehouses.

△ **In food industry applications, Carlo Gavazzi Technical Service has to verify the compatibility of the material of the safety light curtain housing with any chemical agents used in the production process.**

Example 1: Hand protection on moulding machines

In order to protect the light curtain against dust and humidity, a IP69K protective enclosure can be used.

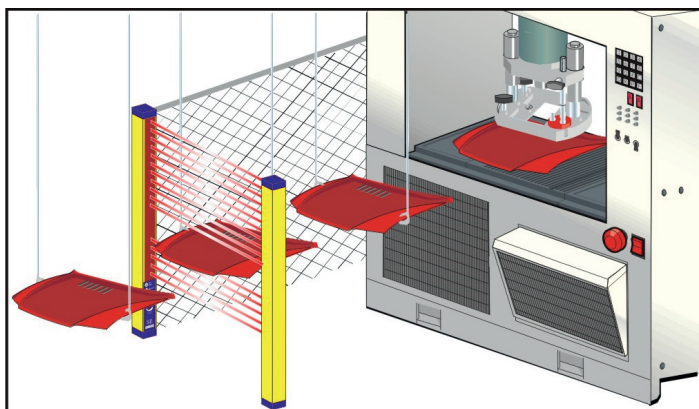

The aim is to prevent operator's hands from being squashed during the final product stacking process. In addition, the solution must not interfere with the manufacturing process.

Solution:

The new SC2 safety light curtains present an ideal solution to safely monitor a moulding application, whilst optimising the manufacturing process.

Advantages:

The use of the new SC2 range ensures the safety of the operator thanks to its enhanced response time, meeting ergonomic and productivity requirements, as the protected area always remains accesible when the machine stops.

Example 2: Cooling and conditioning systems

Cooling and conditioning systems, as well as automotive equipment and components are checked inside a machine, to detect possible leaks by a helium mass spectrometer. The point where these parts are positioned inside the measuring chamber requires a Type 2 protection ensuring a certain space saving and an easy access to the protected area.

Solution:

The SC2 safety light curtain series represents the ideal solution when the safety requirements and the application are considered. Even when just one of the light curtain beams is interrupted, the test machine is immediately stopped.

Advantages:

The SC2 light curtain meets the customer's needs when easy access is necessary in presence of machine stops. Easy installation, configuration and use are other advantages.

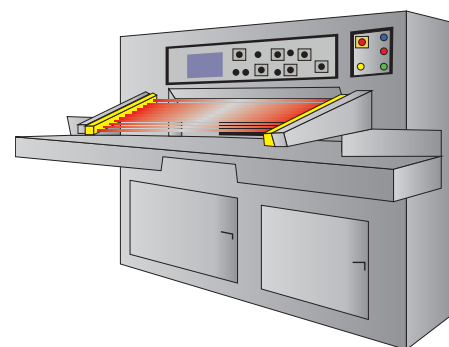

Example 3: Automatic warehouses

Operator protection in automatic warehouses.

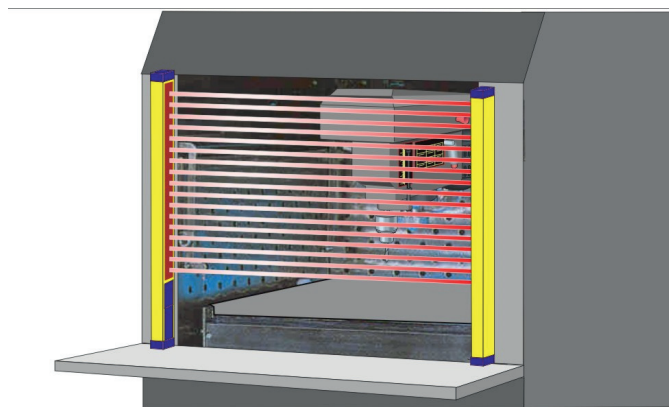

Solution:

The SC2 safety light curtain series represents the ideal solution if the safety requirements and the application are considered. When even just one of the light curtain beams is interrupted, the carousel is immediately stopped.

Advantages:

The SC2 light curtain meets the customer's needs when easy access is necessary in presence of machine stops. Easy installation, configuration and use are other advantages.



1.5. Safety Information

⚠ For a correct and safe use of the safety light curtains of the SC2 series, the following points must be observed:

- The stopping system of the machine must be electrically controlled.
- This control system must be able to stop the dangerous movement of the machine within the total machine stopping time T as per section 1.3.3, and during all working cycle phases.
- Mounting and connection of the safety light curtain must be carried out only by qualified personnel, according to the indications included in the special sections (refer to sections 2; 3; 4; 5) and in the applicable Standards.
- The safety light curtain must be securely installed in a particular position so that access to the dangerous zone is not possible without the interruption of the beams (see section 2 “Installation mode”).
- The personnel operating in the dangerous area must be well trained and must have adequate knowledge of all the operating procedures of the safety light curtain.
- The TEST button must be located outside the protected area because the operator must check the protected area during all Test and Reset operations.

Please carefully read the instructions for the correct functioning before powering the light curtain.



2. Installation Mode

2.1. Precautions to be Observed for the Choice and Installation of the Device

⚠ Make sure that the protection level assured by the SC2 device (Type 2) is compatible with the real danger level of the machine to be controlled, according to EN 954-1 and EN ISO 13849-1:2008.

- The outputs (OSSD) of the ESPE must be used as machine stopping devices and not as command devices. The machine must have its own START command.
- The dimension of the smallest object to be detected must be larger than the resolution level of the device.
- The ESPE must be installed in a room complying with the technical characteristics indicated in section 10 “Technical data”.
- Do not place the device near intense and/or flashing light sources and, in particular, close to receiving unit front surface.
- The presence of intense electromagnetic disturbances could affect device correct operation. This condition shall be carefully assessed by seeking the advice of Carlo Gavazzi Technical service.
- The operating distance of the device can be reduced in presence of smog, fog or airborne dust.
- A sudden change in environment temperature, with very low minimum peaks, can generate a small condensation layer on the lenses and so jeopardise functioning.

2.2. General Information on Device Positioning

The safety light curtain should be carefully positioned, in order to reach a very high protection standard. Access to the dangerous area must only be possible by passing through the protecting safety light beams.

⚠ Fig. 5a shows some examples of possible access to the machine from the top and the bottom sides. These situations may be very dangerous and so the installation of the safety light curtain at sufficient height in order to completely cover the access to the dangerous area (Fig.5b) becomes necessary.

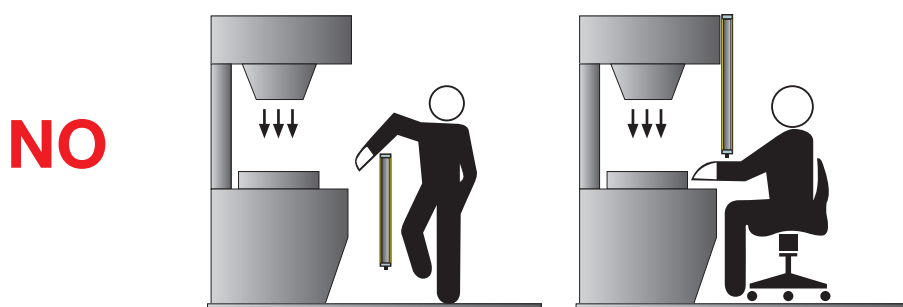

Fig.5a

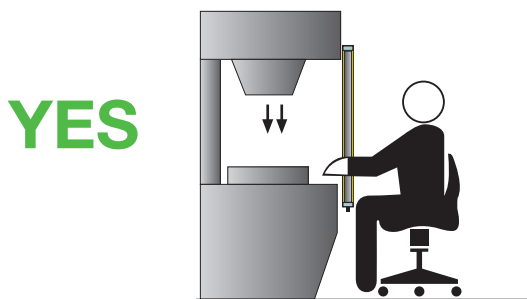

Fig.5b

Under standard operating conditions, machine starting must not be possible while operators are inside the dangerous area.

When the installation of the safety light curtain very near to the dangerous area is not possible, a second light curtain must be mounted in a horizontal position in order to prevent any lateral access (as shown in Fig.6b).

⚠ If the operator is able to enter the dangerous area, an additional mechanical protection must be mounted to prevent the access.

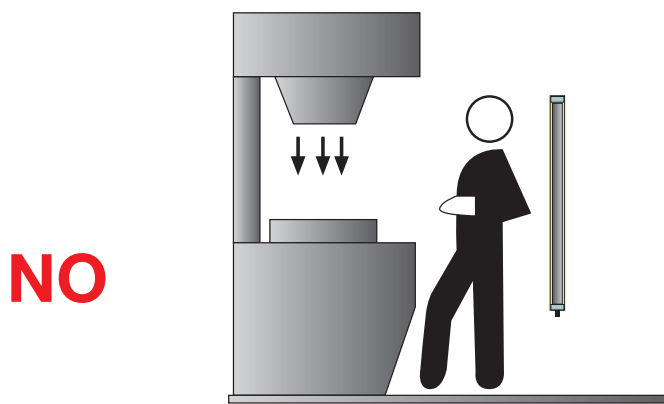

Fig.6a

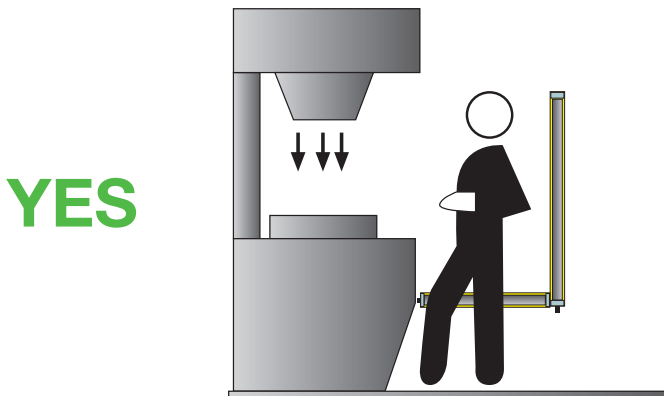

Fig.6b

2.2.1. Minimum Installation Distance

Refer to section 1.3.3. “Minimum installation distance”



2.2.2. Minimum Distance From Reflecting Surface

Reflecting surfaces placed near the light beams of the safety device (over, under or laterally) can cause passive reflections. These reflections can compromise the recognition of an object inside the controlled area.

However, if the **RX** receiver detects a secondary beam (reflected by the side-reflecting surface) the object might not be detected, even if the object interrupts the main beam.

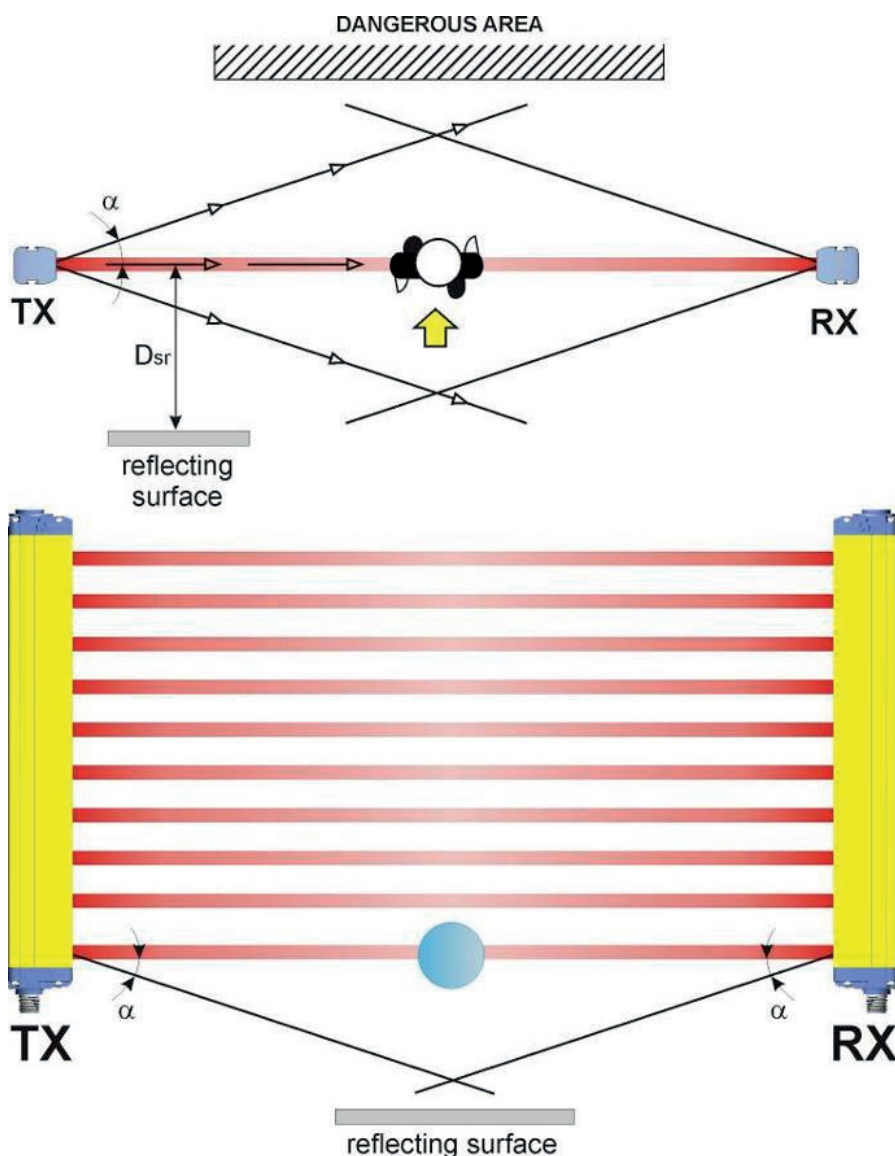

Fig.7



It is thus important to position the safety light curtain according to the minimum distance from reflecting surfaces.

The minimum distance depends on:

- Operating distance between emitter (TX) and receiver (RX);
- Real opening angle of ESPE (EAA); in particular:

for ESPE type 2 EAA = 10° ($\alpha = 5^\circ$)

Diagram of Fig. 8 shows the min. distance from the reflecting surface (Dsr), based on the operating distance:

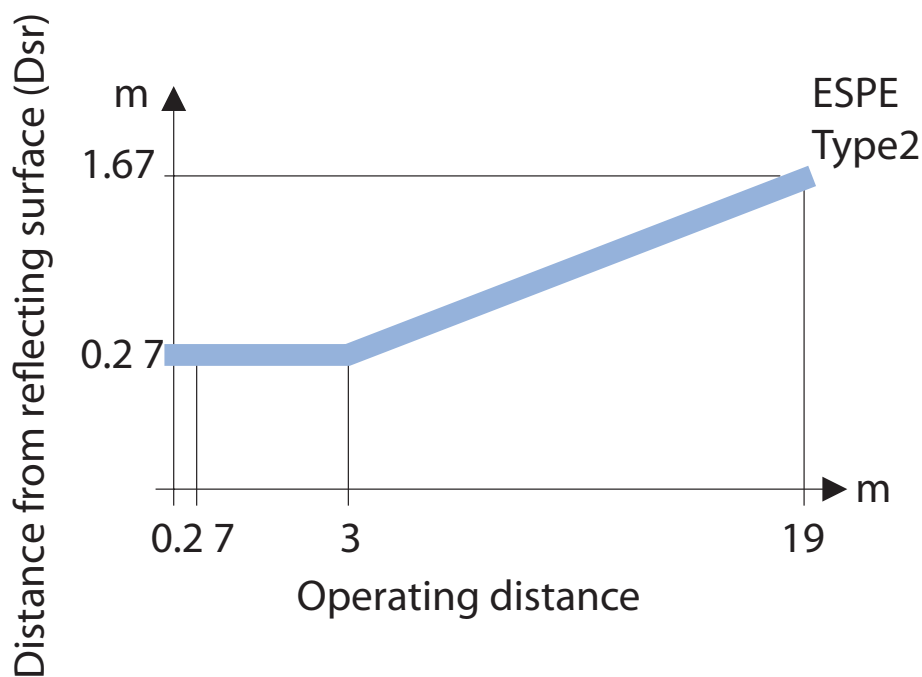

Fig.8

The formula to get Dsr is the following:

$$Dsr (m) = 0.27 \quad \text{for oper. distances} < 3 \text{ m}$$

$$Dsr (m) = 0,5 \text{ operating distance (m)} \times \text{tg } 2\alpha \quad \text{for oper. distances} \geq 3 \text{ m}$$



2.2.3. Emitter and Receiver Orientation

The two units shall be installed parallel to each other, with the beams orthogonal respect to the emitting and receiving directions, with the connectors positioned in the same manner.

The configurations shown in Fig. 9 must be avoided:

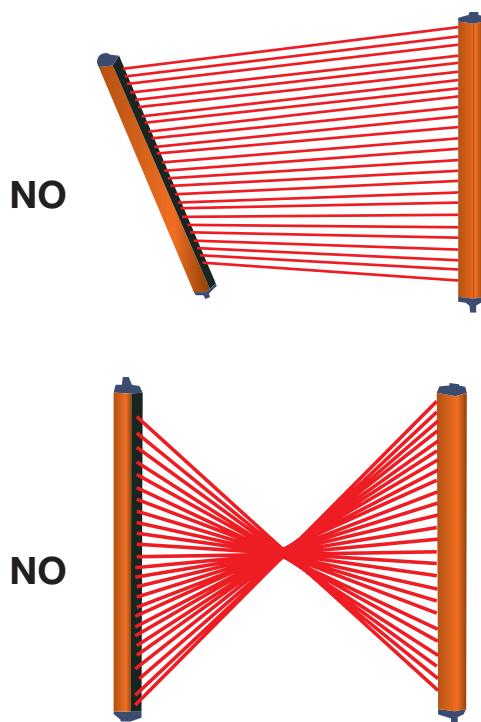

Fig.9

2.2.4. Emitter and Receiver Orientation

When several safety devices must be installed in adjacent areas, interferences between the emitter of one device and the receiver of the other must be avoided.

Fig.10 provides an example of possible interferences between different devices and two pertinent solutions.

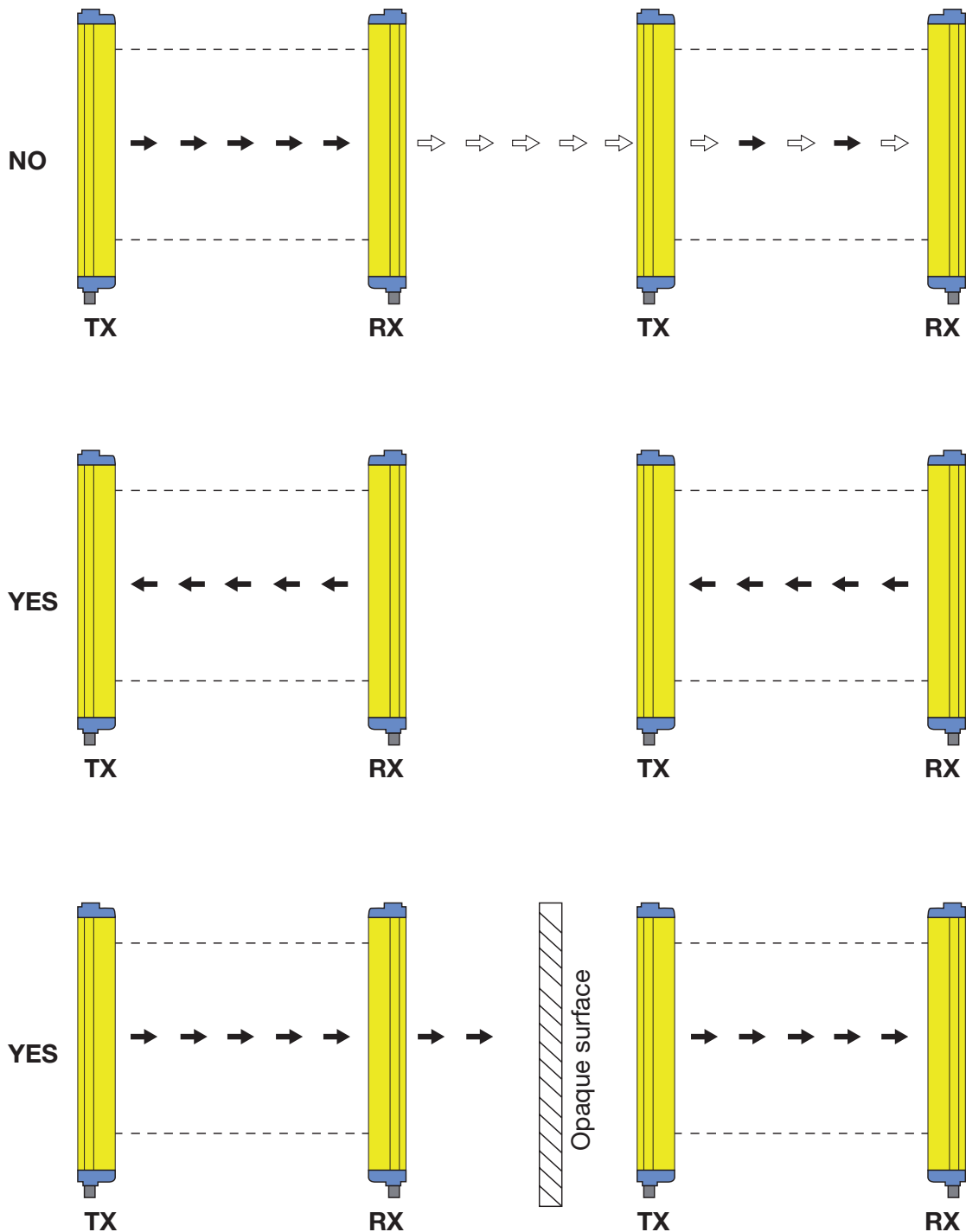

Fig.10

2.2.5. Use of Deviating Mirrors

The control of any dangerous area, with several but adjacent access sides, is possible using only one safety device and well-positioned deviating mirrors.

Fig.11 shows a possible solution to control three different access sides, using two mirrors placed at 45° with respect to the beams.

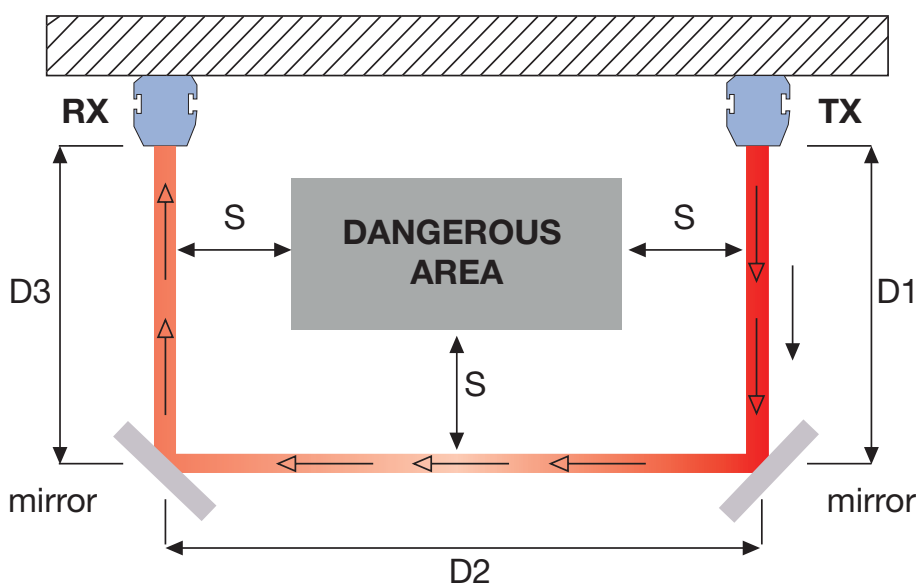

Fig.11

The operator must respect the following precautions when using the deviating mirrors:

- The alignment of the emitter and the receiver can be a very critical operation when deviating mirrors are used. Even a very small mirror displacement is enough to lose alignment.
- The minimum safety distance (S) must be respected for each single section of the beams.
- The effective operating range decreases by about 15% by using only one deviating mirror, the percentage further decreases by using 2 or more mirrors (for more details refer to the technical specifications of the mirrors used).

The following table shows the operating distances relating to the number of mirrors used.

Number of mirrors	Operating distance
1	16.5 m
2	13.7 m
3	11.6 m

- Do not use more than three mirrors for each device.
- The presence of dust or dirt on the reflecting surface of the mirror causes a drastic reduction in the range.

2.2.6. Controls After Installation

- The control operations to carry-out after the first installation and before machine start-up are listed hereinafter. The controls must be carried-out by qualified personnel, either directly or under the strict supervision of the person in charge of machinery Safety.

Verify that:

- ESPE remains blocked () intercepting the beams along the protected area using the specific test piece, following the Fig.12 scheme.

TP30 for light curtains with 30 mm resolution for example:

SC2-AR-30-150-D19

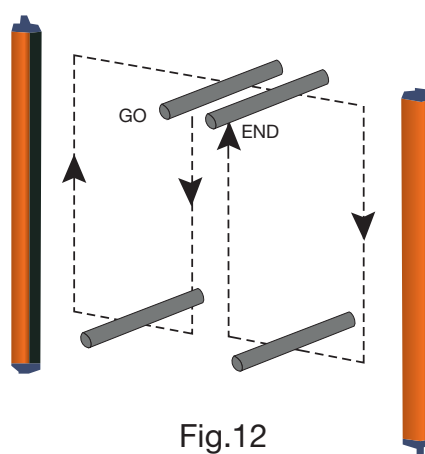



Fig.12

- ESPE has to be correctly aligned, press slightly on the product side in both directions the red LED must not turn on  .
- The activation of the TEST function causes the opening of the OSSD outputs (red LED  on and controlled machine stop).
- The response time at machine STOP, including the ESPE and machine response times, must be included in the limits defined in the calculation of the safety distance (refer to section 2 “Installation modes”).
- The safety distance between the dangerous parts and ESPE must comply with the requirements indicated in section 2 “Installation modes”.
- A person must not access or remain between ESPE and the dangerous parts of the machine.
- Access to the dangerous areas of the machine must not be possible from any unprotected area.
- ESPE must not be disturbed by external light sources, ensuring that it remains in Normal operating function for at least 10-15 minutes and placing the specific test piece in the protected area in the SAFE condition for the same period.
- Verify the correspondence of all the accessory functions, activating them in the different operating conditions.



3. Mechanical Mounting

The emitting (TX) and receiving (RX) units must be installed with the relevant sensitive surfaces facing each other. The connectors must be positioned on the same side and the distance must be included within the operating range of the model used (see section 10 “Technical data”).

The two units must be positioned the most aligned and parallel possible. The next step is the fine alignment, as shown in section 5 “Alignment Procedure”.

Two types of brackets can be used to fix the two units:

Angled fixing brackets

Angled fixing brackets are supplied with all SC2 models (Fig.13). Adjustable supports for correcting unit inclination on the axes are available on request (see section.14 “Accessories”).

For fixing with angled brackets, refer to Fig.13.

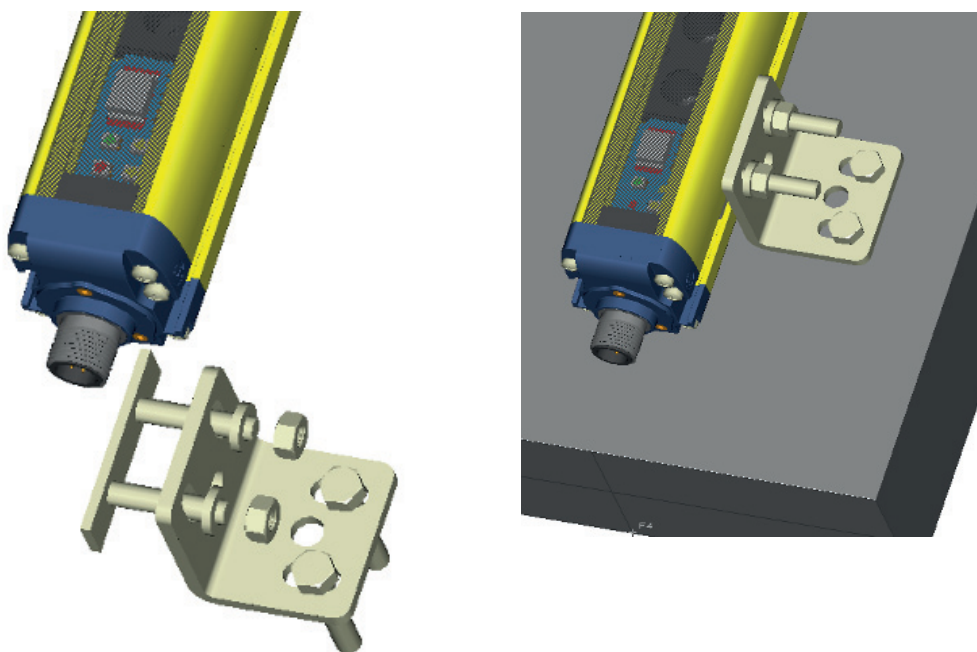

Fig.13

Rotating brackets

Rotating brackets (Fig.14), available upon request, can be used as an alternative or together with angled brackets.

For fixing with rotating bracket, refer to Fig.14.

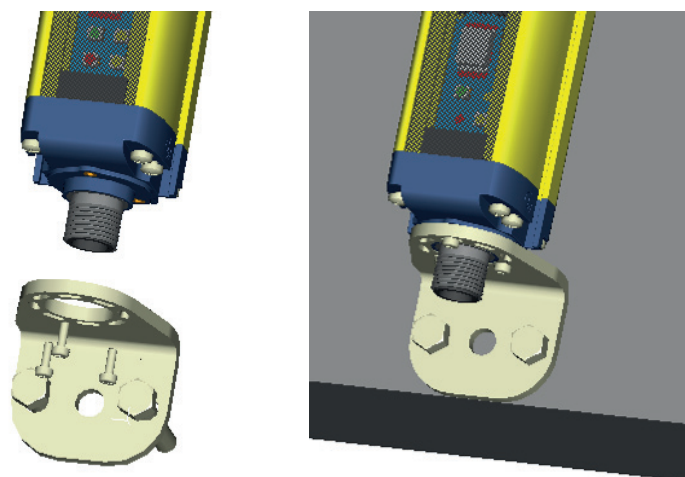

Fig.14

In case of applications with particularly strong vibrations, vibration dampers, together with mounting brackets, are recommended to reduce the impact of the vibrations.

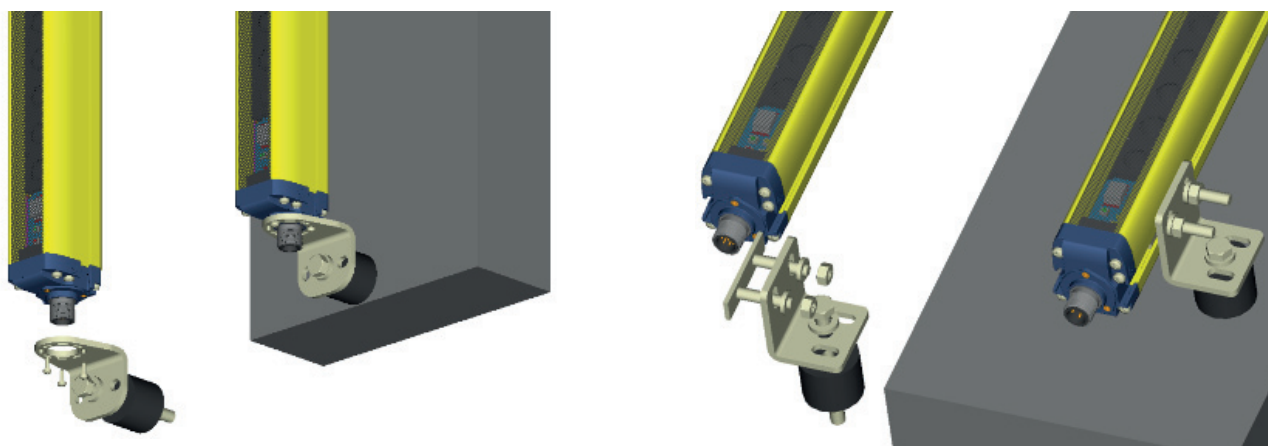
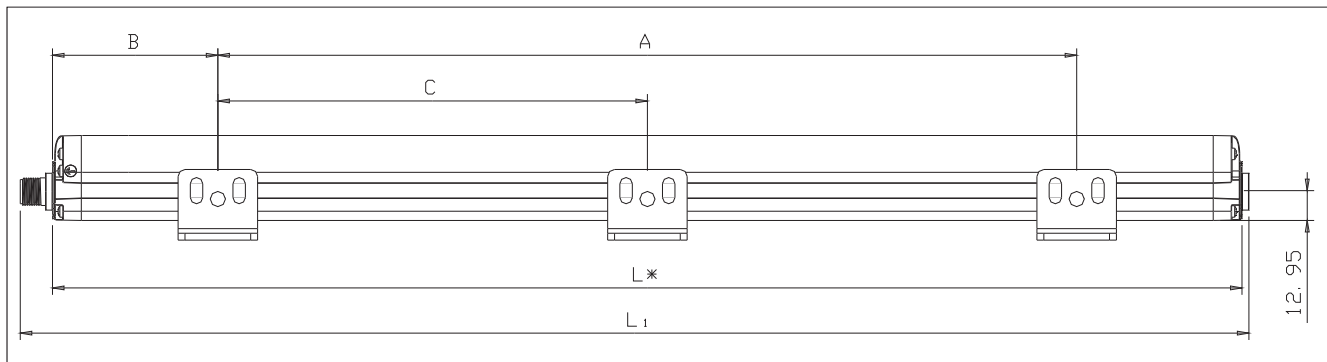

Fig.15

The recommended mounting positions according to the light curtain length are shown in Fig.15 and in the following table.



Models	L (mm)	A (mm)	B (mm)	683C (mm)
SC2-AR-30-150-D19	216.3	108	54	-
SC2-AR-30-300-D19	366.2	216	75	-
SC2-AR-30-450-D19	516.3	316	100	-
SC2-AR-30-600-D19	666.2	366	150	-
SC2-AR-30-750-D19	816.3	466	175	-
SC2-AR-30-900-D19	966.2	566	200	-
SC2-AR-30-1050-D19	1116.2	666	225	-
SC2-AR-30-1200-D19	1266.3	966	150	483
SC2-AR-30-1350-D19	1416.2	1066	175	533
SC2-AR-30-1500-D19	1566.3	1166	200	533

Models	L (mm)	A (mm)	B (mm)	683C (mm)
SC2-AR-90-300-D19	366.2	216	75	-
SC2-AR-90-450-D19	516.3	316	100	-
SC2-AR-90-600-D19	666.2	366	150	-
SC2-AR-90-750-D19	816.3	466	175	-
SC2-AR-90-900-D19	966.2	566	200	-
SC2-AR-90-1050-D19	1116.2	666	225	-
SC2-AR-90-1200-D19	1266.3	966	150	483
SC2-AR-90-1350-D19	1416.2	1066	175	533
SC2-AR-90-1500-D19	1566.3	1166	200	533



4. Electrical Connection

All electrical connections to the emitting and receiving units are made through a male M12 connector, located on the lower part of the two units. For receiver a M12 5-pole connector is used, while for emitter a M12 4-pole connector is used.

RECEIVER (RX):

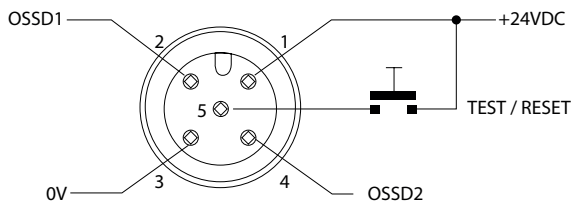

- 1 = Brown = +24VDC
- 2 = White = OSSD 1
- 3 = Blue = 0V
- 4 = Black = OSSD 2
- 5 = Grey = TEST/RESET

EMITTER (TX):

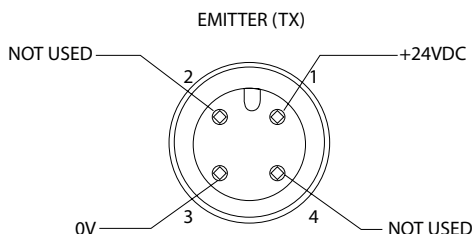

- 1 = Brown = +24VDC
- 2 = White = NOT USED
- 3 = Blue = 0V
- 4 = Black = NOT USED



4.1. Notes of Connections

For the correct functioning of the SC2 safety light curtains, the following precautions regarding the electrical connections have to be respected:

- Do not place connection cables in contact with or near high-voltage cables and/or cable undergoing high current variations (e.g. motor power supplies, inverters, etc.);

⚠ Do not connect in the same multi-pole cable the OSSD wires of different light curtains;

- The TEST/RESET wire must be connected through a N.O. button to the supply voltage of the ESPE.

⚠ **The TEST/RESET button must be located in such a way that the operator can check the protected area during any Test and Reset operation. (see section 6 “Functioning mode”).**

- The device is protected internally against overvoltage and overcurrent. The use of other external components is not recommended.

Example: connection with safety relay

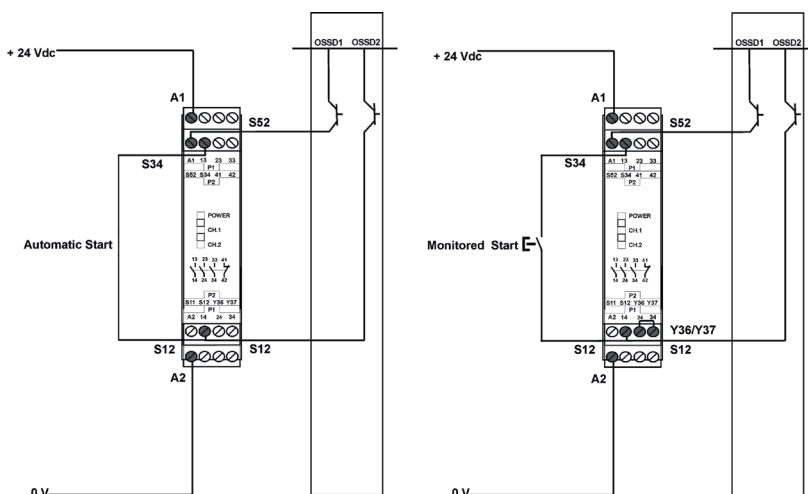

The figures show the connection between the safety light curtains and a safety relay functioning in the Automatic Start mode (left side) and Manual Start with monitoring (right side).

⚠ Do not use varistors, RC circuits or LEDs in parallel at relay inputs or in series at OSSD outputs.

- The OSSD1 and OSSD2 safety contacts cannot be connected in series or in parallel, but can be used separately (Fig.16).

If one of these configurations is erroneously used, the device enters into the output failure condition (see section 7 “Diagnostic functions”).



- Connect both OSSDs to the activating device. Failure to connect an OSSD to the activating device jeopardises the system safety degree that the light curtain has to control

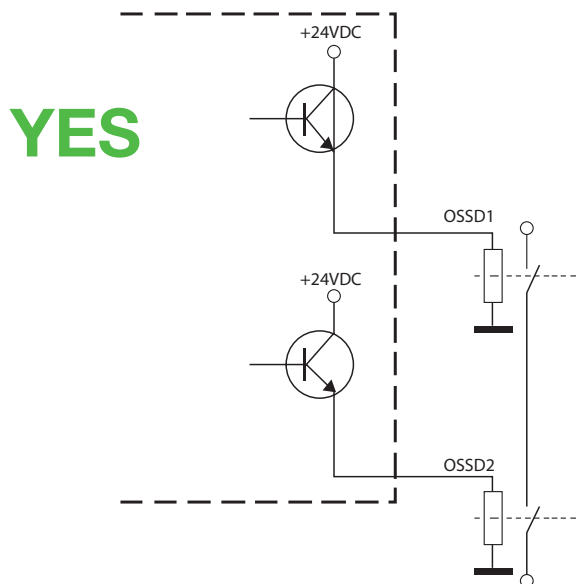

Fig.16

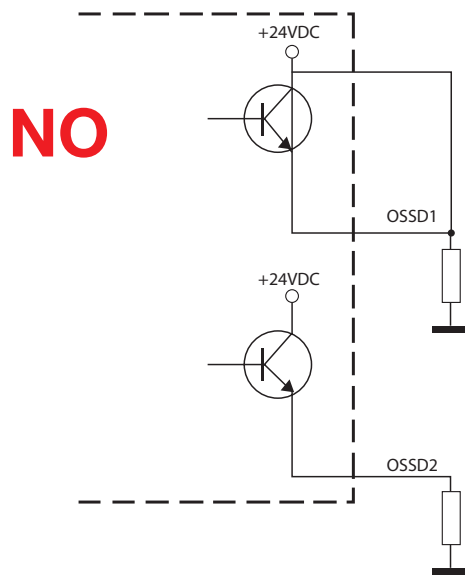

Fig.17

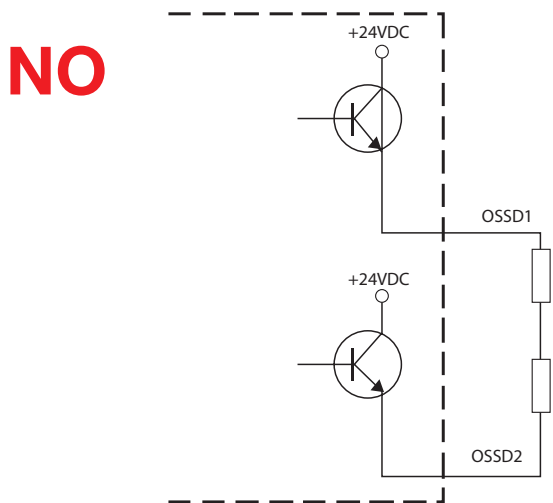

Fig.18

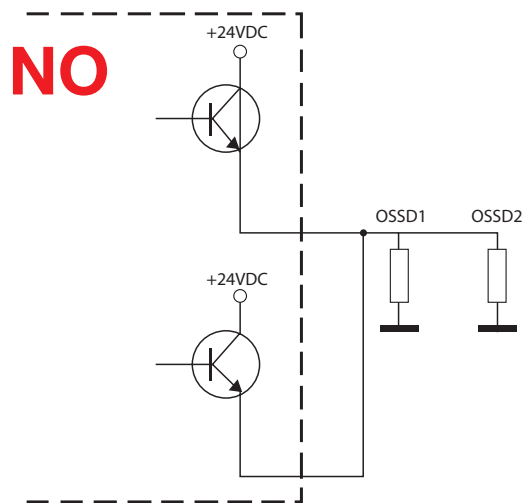

Fig.19

4.2. Earth Connection

SC2 safety light curtain units are preset for easy ground connection. A special compartment, positioned onto caps and marked with the special symbol shown in Figure 20, allows connection with ground cable by means of an additional screw coming with the equipment.

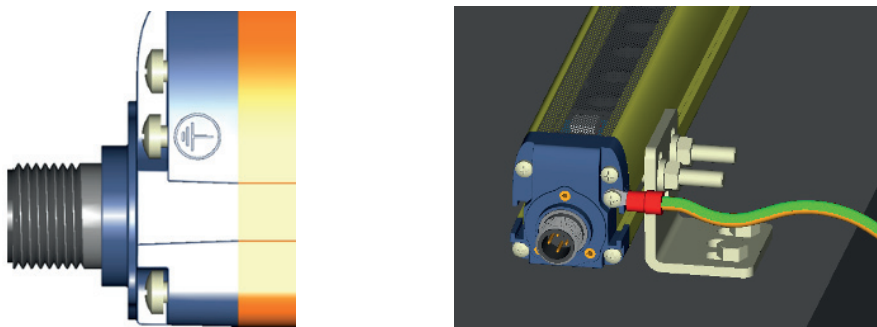

Fig.20

Ground connection configuration is the most common and guarantees the best immunity against electromagnetic disturbances. SC2 can function even without ground connection. This condition has to be carefully evaluated according to the EMC disturbance immunity and necessary insulation class considering the plant or entire system where the light curtain is installed.

- The ground connection of the two units is not necessary for Class III, while the use of a duly insulated low-voltage feeder type SELV or PELV is compulsory. In this case, we recommend covering the earth symbol present on the caps of the two units with a blank sticker.
- The ground connection of the two units is compulsory for Class I, while the use of a duly insulated feeder type SELV or PELV is not compulsory but anyway recommended.

The following table is a summary of SC2 electrical protections.

Electrical protection	Class I	Class III
Ground connection	Compulsory	Not necessary
Ground connection symbol	Compulsory	Not necessary
Power supply by generators SELV / PELV	Recommended	Compulsory



5. Alignment Procedure

The alignment between the emitting and the receiving units is necessary to obtain the correct functioning of the light curtain.

A good alignment prevents outputs instability caused by dust or vibrations.

The alignment is perfect if the optical axes of the first and the last emitting unit's beams coincide with the optical axes of the corresponding elements of the receiving unit.

The beam used to synchronise the two units is the first after the connector. SYNC is the optics connected with this beam and LAST is the optics connected to the last beam after the SYNC unit.

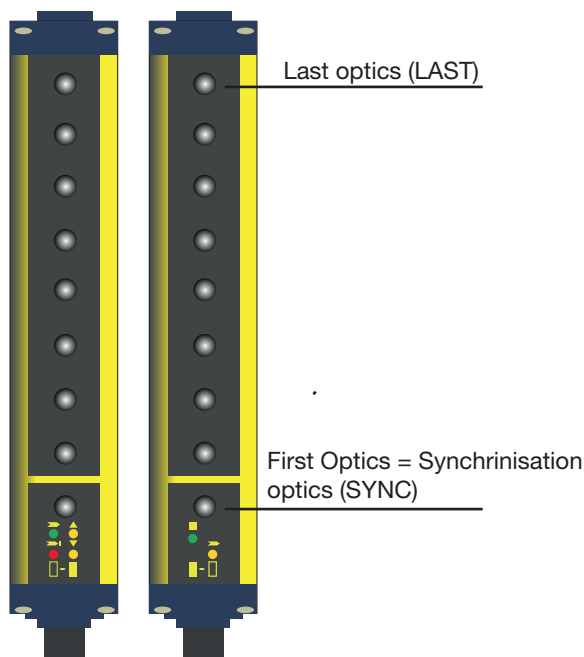

Fig.21

Signals are clearly identified through symbols allowing immediate reading, independent of bars directions. A short description of the signalling LEDs is necessary to avoid misunderstandings.

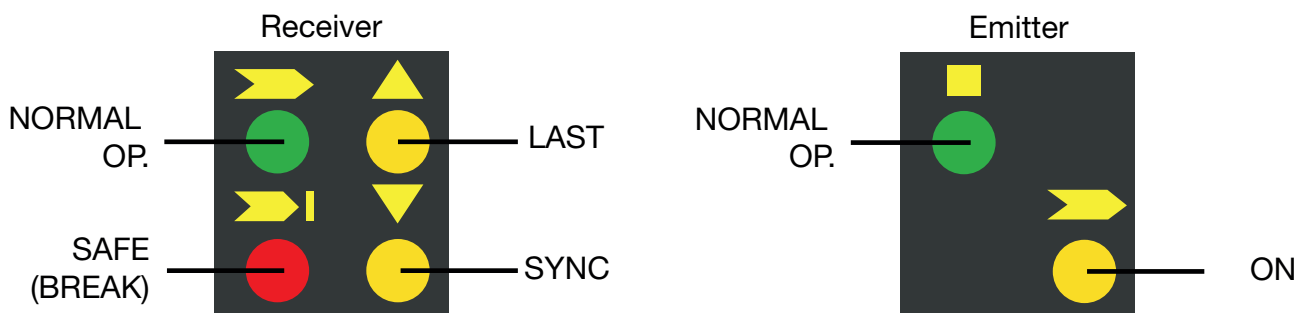

Fig.22



The standard installation described hereinafter is the one shown in Fig. 22, i.e. with the bar assembled with the connectors pointing down.

Two yellow LEDs (▲ LAST, ▼ SYNC) on SC2 receiver, facilitates the alignment procedure. During standard operation, the LEDs indicate the safety light curtain status, as shown in the table.

FUNCTIONING STATUS

LED colour	Symbol	Stop Status	Stop Status		
		NORMAL OP.	SAFE (BREAK)		
Yellow	▲	OFF	ON	OFF	OFF
Yellow	▼	OFF	ON	ON	OFF
Red	▶	OFF	ON	ON	ON
Green	▶	ON	OFF	OFF	OFF
		- Standard condition: - Not interrupted beams	- Units not aligned - Top side not aligned - Highest beam interrupted	- Bottom side not aligned - Lowest beam interrupted	Units aligned, but at least one of beams (the highest and lowest excluded) is interrupted



5.1. Correct Alignment Procedure

The light curtain alignment can be effected only after having completed the mechanical installation and the electrical connections. The following procedure has to be followed:

- Check the green LED (■) and the yellow LED (►) on the TX unit. If ON, the emitter is running correctly;
- Verify that the sensitive area from the safety light curtain is free;
- Verify that one of the following conditions is present on the RX unit:

1. STANDARD CONDITION - NORMAL OP.

Green LED (►) ON and red LED (► |) OFF.

Both yellow LEDs (▲, ▼) are OFF.

Units are aligned.

2. STOP CONDITION - SAFE (BREAK)

Green LED (►) OFF and red LED (► |) ON.

The status of both yellow LEDs (▲, ▼) does not matter.

Units are not aligned.

Continue with the following steps to pass from condition 2 to condition 1:

- Keep the receiver in a steady position and set the emitter until the yellow LED (▼SYNC) is OFF. This condition shows the effective alignment of the first synchronisation beam.
- Rotate the emitter, pivoting on the lower optics axis, until the yellow LED (▲LAST) is OFF. Under these conditions, the SAFE LED shall turn ON.

NOTE: Ensure that the green LED ► is steady ON.

- Delimit the area in which the LED ► is steady through some micro adjustments - for the first and then for the second unit - then place both units in the centre of this area.
- Fix the two units firmly using brackets.
- Verify that the green LED on the RX unit is ON (► |) and beams are not interrupted, then verify that the red LED turns ON if even one single beam is interrupted (condition where an object has been detected).
- This verification shall be made with the special cylindrical “Test Piece” having a size suitable to the resolution of the device used.

NOTE: Passing the Test Piece along the whole sensitive area and at any distance from the two units, the red LED (► |) shall be always ON and never change status.

A daily test is recommended.



6. Function Mode

6.1. Reset Mode

The interruption of a beam due to an opaque object causes the opening of OSSD outputs and the stop of the safety light curtain SAFE (BREAK) condition ➡ I. The ESPE will automatically restart its standard operation (NORMAL OP. condition ➡) as soon as the object is removed.

⚠WARNING: Carefully assess risk conditions and reset modes. In applications protecting access to dangerous areas, the automatic reset mode is potentially unsafe if it allows the operator to pass completely beyond the sensitive area (see Fig. 6b). In this case, the reset, using for example the manual reset of the relay, (page 26) might be necessary.

6.2. Test Function

The TEST function can be activated by keeping a normally open external contact (TEST push-button), closed for at least 0.5 seconds.

The TEST signal is active high.

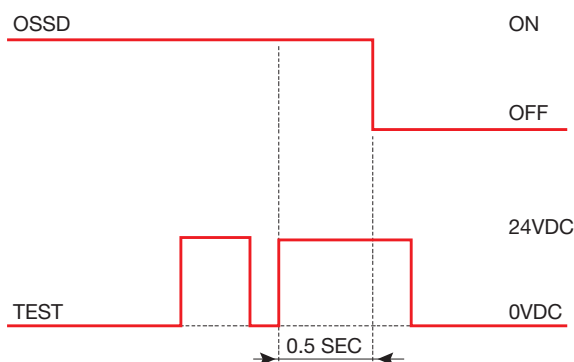

6.3. Reset Function

The RX light curtain has a RESET function which is activated after an internal error. The reset can be made only in case of optical error or OSSD error (See sect. 7 “Diagnostic Functions”) The RESET function can be activated by keeping a normally open external contact (RESET/RESTART push-button), closed for at least 5 seconds.

The RESET signal is active high.

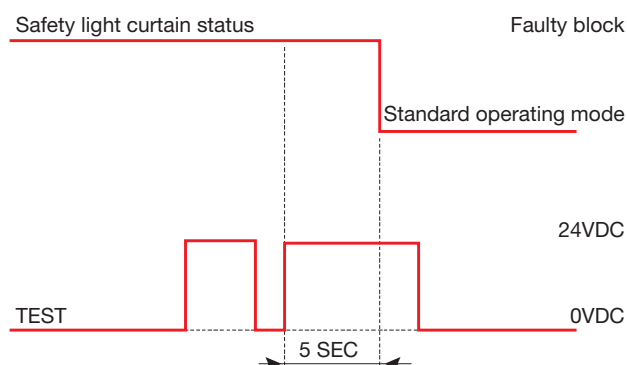

7. Diagnostic Function

7.1. User Interface

The operator can visualise the operating condition of the light curtains through the four LEDs positioned on the receiver unit and two LEDs on the emitter unit. Fig.23 shows all signalling LEDs modes: OFF, ON and BLINKING.

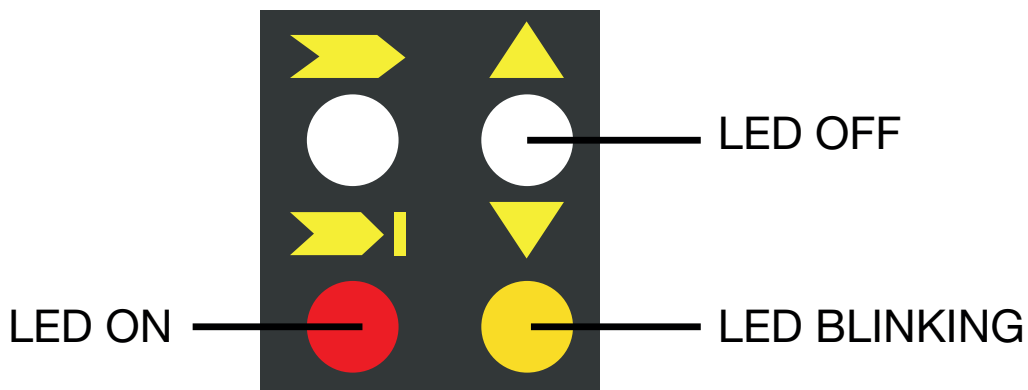

Fig.23



7.2. Diagnostic Messages

The operator is able to check the main causes of the system stop and failure, using the same LEDs used for visualising the functions.

For receiver:

Function	Status	Meaning	LED
Nomal operation	TEST (red ON)	Light curtain being tested, the OSSD status shall be OFF	
	Emission (OSSD ON) (green ON)	Light curtain working and in normal operating conditions	
	Interruption (OSSD OFF) (red ON)	Light curtain working and in safety block conditions.	
Function	Type	Check and repair	LED
Error Status	OSSD error (yellow and red BLINKING)	Check OSSD connections; make sure that they are not in contact with one another or with the supply cables, then Reset. If the failure continues contact Carlo Gavazzi	
	Internal error (red ON yellow BLINKING)	Switch OFF and switch ON the supply circuit; if the failure continues contact Carlo Gavazzi	
	Optical error (red ON yellow BLINKING)	Reset. If the failure continues contact Carlo Gavazzi	
	No power supply (LEDs OFF)	Check connections and input voltage correct value. If the failure continues contact Carlo Gavazzi	

For emitter:



Function	Status	Meaning	LED
Nomal operation	Test (green ON)	Light curtain being tested, the OSSD status shall be OFF	
	Emission (green ON yellow ON)	Light curtain working and in normal operating conditions	
Function	Type	Check and repair	LED
Error Status	Internal error (green ON yellow BLINKING)	Switch OFF and switch ON the supply circuit; if the failure continues contact Carlo Gavazzi	
	Optical error (green ON yellow blinking)	Switch OFF and switch ON the power supply circuit. If the failure continues contact Carlo Gavazzi	
	No power supply (LEDs OFF)	Check connections and input voltage correct value. If the failure continues contact Carlo Gavazzi	



8. Periodical Checks

The following is a list of recommended check and maintenance operations that should be periodically carried out by qualified personnel.

Check that:

- The ESPE stays locked ( I) during beam interruption along the entire protected area, using the suitable "Test Piece". (*)
- The ESPE is correctly aligned: by slightly pressing product side, in both directions, the red LED shall not come ON  I.
- Enabling the TEST function, the OSSD outputs should open (the red LED  I is ON and the controlled machine stops).
- The response time upon machine STOP (including response time of the ESPE and of the machine) is within the limits defined for the calculation of the safety distance (see section 2 "Installation mode").
- The safety distance between the dangerous areas and the ESPE are in accordance with the instructions included in section 2 "Installation mode".
- Access of a person between ESPE and machine dangerous parts is not possible nor is it possible for him/her to stay there.
- Access to the dangerous area of the machine from any unprotected area is not possible.
- The ESPE and the external electrical connections are not damaged.

The frequency of checks depends on the particular application and on the operating conditions of the safety light curtain.

(*) according to the Fig.12 scheme

Verify that:

- ESPE remains blocked ( I) intercepting the beams along the protected area using the specific test piece, following the Fig.12 scheme.

TP30 for light curtains with 30 mm resolution for example: SC2-AR-30-150-D19



8.1. General Information and Useful Data

Safety **MUST** be a part of our conscience.

The safety devices fulfil their safety function only if they are correctly installed, in accordance with the Standards in force.

If you are not certain to have the expertise necessary to install the device in the correct way, Carlo Gavazzi Customer Service is at your disposal to carry out the installation.

The device uses fuses that are not self-resetting. Consequently, in presence of short-circuits causing the cut-off of these fuses, both units shall be sent to Carlo Gavazzi service department.

A power failure caused by interferences may cause the temporary opening of the outputs, but the safe functioning of the light curtain will not be compromised.

8.2. Warranty

Carlo Gavazzi guarantees each brand new SC2 system, under standard use conditions, against manufacturing defects in material and workmanship for a period of 36 (thirty-six) months from the date of manufacturing.

Carlo Gavazzi will not be liable for any damages to persons and things caused by failure to stick to the correct installation modes and device use.

Warranty validity is subject to the following conditions:

- User shall notify Carlo Gavazzi the failure within thirty-six months from product manufacturing date.
- Failure or malfunction shall not have been originated directly or indirectly by:
 - use for unsuitable purposes;
 - failure to comply with the intended use prescriptions;
 - negligence, unskillfulness, wrong maintenance;
 - repairing, changes, adaptations not made by Carlo Gavazzi personnel, tampering with the device, etc.;
- accidents or crashes (even due to transportation or by force majeure causes);
- other causes not depending from Carlo Gavazzi

If the device does not work, send both units (receiver and emitter) to Carlo Gavazzi. The Customer is responsible for all transport charges and damage risks or material loss during transport, unless otherwise agreed.

All replaced products and parts become a property of Carlo Gavazzi.

Carlo Gavazzi does not accept any warranty or right other than the above-described ones. No requests for compensation for expenses, activities stop or other factors or circumstances somehow connected to the failure of the product or one of its parts to operate cannot be put forward for any reason.

In case of problems, please contact Carlo Gavazzi Service Department:

Tel: +39 02 931 761

Fax: +39 02 931 763 01



9. Device Maintenance

SC2 safety light curtains do not require special maintenance operations.

To avoid the reduction of the operative distance, optics protective front surfaces shall be cleaned at regular intervals.

To this end, use soft cotton cloths damped in water; do not apply too much pressure onto the surface so as not to make it dull.

Please do not use on plastic surfaces or light curtain painted surfaces:

- Alcohol or solvents
- Wool or synthetic cloths
- Paper or other abrasive materials

9.1. Product Disposal

Under current Italian and European laws, Carlo Gavazzi is not obliged to take care of product disposal at the end of its life.

Carlo Gavazzi recommends to dispose of the product in compliance with local laws or contact authorised waste collection centres.



10. Technical Data

The product technical specifications are given below.

ELECTRICAL DATA	
Power supply (Vdd):	24 Vdc \pm 20%
Unit current draw (TX):	2 W max
Unit current draw (RX):	3.5 W max (without load)
Outputs:	2 PNP
Short-circuit protection:	1.4 A max
Output current:	0.5 A max / each output
Output voltage - status ON:	Vdd - 1 V min
Output voltage - status OFF:	0.2 V max
Capacitive load:	2.2 μ F @ 24VDC max
Response times:	See table below
Protected height:	150... 1500mm
Safety category:	Type 2
Auxiliary functions:	Reset / Test
Electrical protection:	Class I / Class III
Connections:	M12-4 poles for emitter M12-5poles for receiver
Cables length (for power supply):	50 m. max
OPTICAL DATA	
Emitting light :	Infrared, LED (950 nm)
Resolution:	30 - 50 - 90
Operating distance:	0.2...19m
Ambient light rejection:	IEC-61496-2
MECHANICAL AND ENVIRONMENTAL DATA	
Operating temperature:	-10... + 55°C
Storage temperature:	-25... + 70°C
Humidity:	15... 95% (no condensation)
Mechanical protection:	IP 65 (EN 60529)
Vibrations:	Width 0.35 mm, Frequency 10 ... 55 Hz 20 sweep per axis, 1octave/min (EN 60068-2-6)
Shock resistance:	16 ms (10 G) 1,000 shocks per axis (EN 60068-2-29)
Housing material:	Painted aluminium (yellow RAL 1003)
Front side material:	PMMA
Caps material:	PC MAKROLON
Weight (single unit):	1.3 kg / linear metre



11. List of Available Models

Model	Protected height (mm)	Number of beams	Response time (msec)	Resolution (mm)
SC2-AR-30-150-D19	150	8	8	30
SC2-AR-30-300-D19	300	16	9	30
SC2-AR-30-450-D19	450	24	11	30
SC2-AR-30-600-D19	600	32	12	30
SC2-AR-30-750-D19	750	40	14	30
SC2-AR-30-900-D19	900	48	15	30
SC2-AR-30-1050-D19	1050	56	17	30
SC2-AR-30-1200-D19	1200	64	18	30
SC2-AR-30-1350-D19	1350	72	20	30
SC2-AR-30-1500-D19	1500	80	21	30
SC2-AR-90-300-D19	300	5	9	90
SC2-AR-90-450-D19	450	7	10	90
SC2-AR-90-600-D19	600	9	11	90
SC2-AR-90-750-D19	750	11	12	90
SC2-AR-90-900-D19	900	13	13	90
SC2-AR-90-1050-D19	1050	15	14	90
SC2-AR-90-1200-D19	1200	17	15	90
SC2-AR-90-1350-D19	1350	19	16	90
SC2-AR-90-1500-D19	1500	21	17	90



	EN ISO 13849-1:2008	EN 954-1	EN IEC 61508	EN IEC 62061	Prob. of danger failure/hour	Life span	Mean time to dangerous failure	Average diagnostic coverage	Safe failure fraction	Hardware fault tolerance
Product	PL	CAT	SIL	SIL CL	PFHd (1/h)	T1 (years)	MTTFd (years)	DC	SFF	HFT
SC2-AR-30-150-D19	d	2	2	2	1,04E-08	20	273	97,50%	98,40%	0
SC2-AR-30-300-D19	d	2	2	2	1,04E-08	20	273	97,50%	98,40%	0
SC2-AR-30-450-D19	d	2	2	2	1,04E-08	20	273	97,50%	98,40%	0
SC2-AR-30-600-D19	d	2	2	2	1,04E-08	20	273	97,50%	98,40%	0
SC2-AR-30-750-D19	d	2	2	2	1,04E-08	20	273	97,50%	98,40%	0
SC2-AR-30-900-D19	d	2	2	2	1,04E-08	20	273	97,50%	98,40%	0
SC2-AR-30-1050-D19	d	2	2	2	1,04E-08	20	273	97,50%	98,40%	0
SC2-AR-30-1200-D19	d	2	2	2	1,04E-08	20	273	97,50%	98,40%	0
SC2-AR-30-1350-D19	d	2	2	2	1,04E-08	20	273	97,50%	98,40%	0
SC2-AR-30-1500-D19	d	2	2	2	1,04E-08	20	273	97,50%	98,40%	0
SC2-AR-90-300-D19	d	2	2	2	1,04E-08	20	273	97,50%	98,40%	0
SC2-AR-90-450-D19	d	2	2	2	1,04E-08	20	273	97,50%	98,40%	0
SC2-AR-90-600-D19	d	2	2	2	1,04E-08	20	273	97,50%	98,40%	0
SC2-AR-90-750-D19	d	2	2	2	1,04E-08	20	273	97,50%	98,40%	0
SC2-AR-90-900-D19	d	2	2	2	1,04E-08	20	273	97,50%	98,40%	0
SC2-AR-90-1050-D19	d	2	2	2	1,04E-08	20	273	97,50%	98,40%	0
SC2-AR-90-1200-D19	d	2	2	2	1,04E-08	20	273	97,50%	98,40%	0
SC2-AR-90-1350-D19	d	2	2	2	1,04E-08	20	273	97,50%	98,40%	0
SC2-AR-90-1500-D19	d	2	2	2	1,04E-08	20	273	97,50%	98,40%	0



12. Overall Dimensions

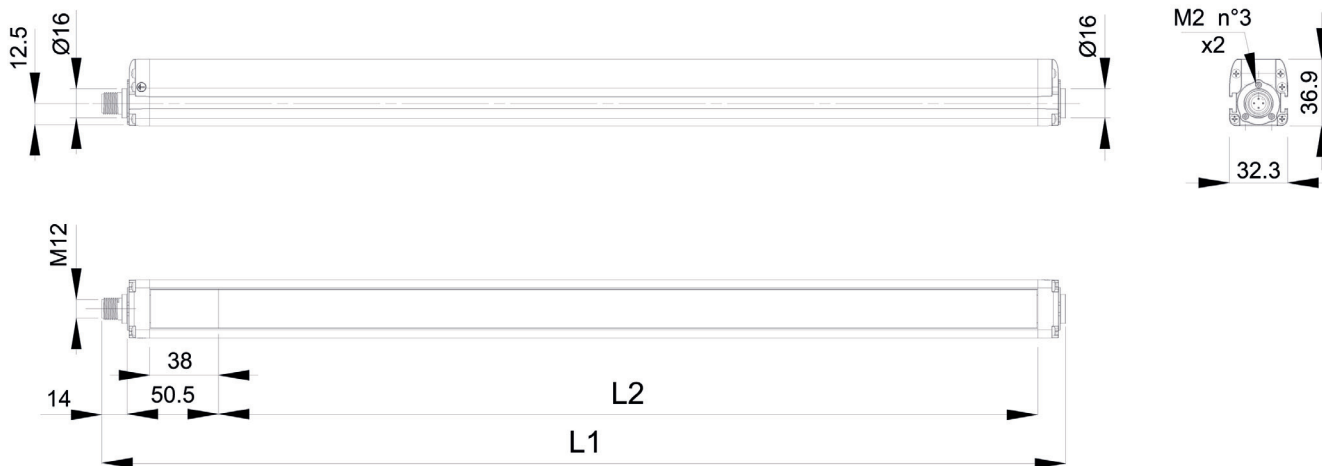

Model	L ₁	L ₂
SC2-AR-30-150-D19	233.3	153.3
SC2-AR-30-300-D19	383.2	303.2
SC2-AR-30-450-D19	533.2	453.3
SC2-AR-30-600-D19	683.2	603.2
SC2-AR-30-750-D19	833.2	753.3
SC2-AR-30-900-D19	983.2	903.2
SC2-AR-30-1050-D19	1133.2	1053.2
SC2-AR-30-1200-D19	1283.3	1203.3
SC2-AR-30-1350-D19	1433.2	1353.2
SC2-AR-30-1500-D19	1583.3	1503.3

Model	L ₁	L ₂
SC2-AR-90-300-D19	383.2	303.2
SC2-AR-90-450-D19	533.2	453.3
SC2-AR-90-600-D19	683.2	603.2
SC2-AR-90-750-D19	833.2	753.3
SC2-AR-90-900-D19	983.2	903.2
SC2-AR-90-1050-D19	1133.2	1053.2
SC2-AR-90-1200-D19	1283.3	1203.3
SC2-AR-90-1350-D19	1433.2	1353.2
SC2-AR-90-1500-D19	1583.3	1503.3



13 Accessories

Model	Description
SC FB4P	Std mounting brackets 4 pcs kit
SC AV4P	Anti Vibration supports 4 pcs kit
SC AV6P	Anti Vibration supports 6 pcs kit
SC OS4P	Orientable Supports 4 pcs kit
SC OS6P	Orientable Supports 6 pcs kit

13.1. Angled Fixing Bracket

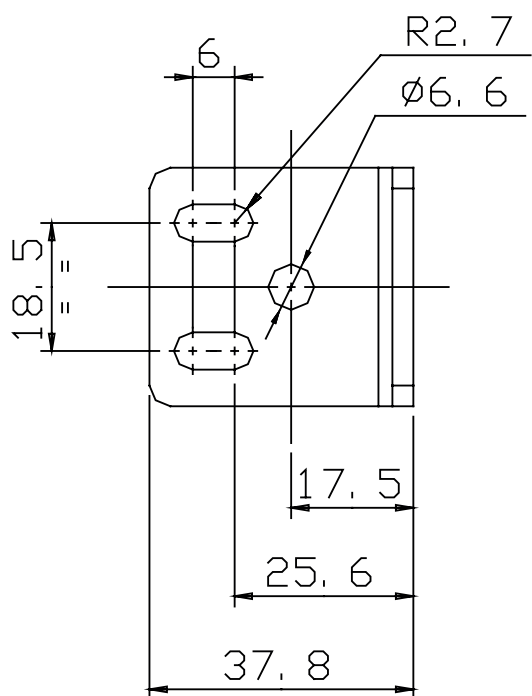
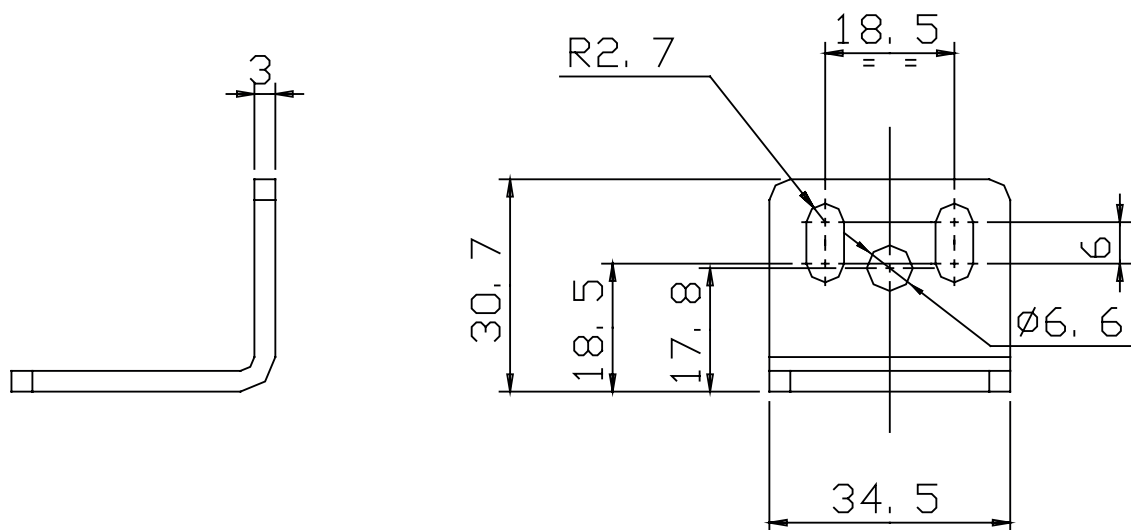

Angled Fixing Bracket Mounting



Angled fixing bracket

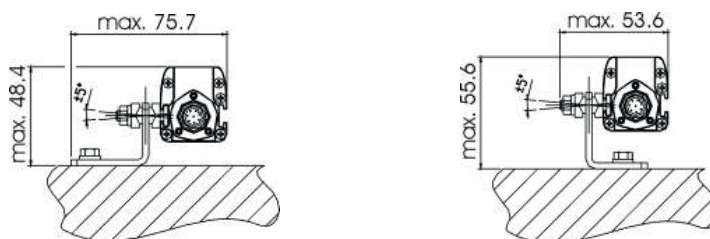

Angled fixing bracket + Adjustable support

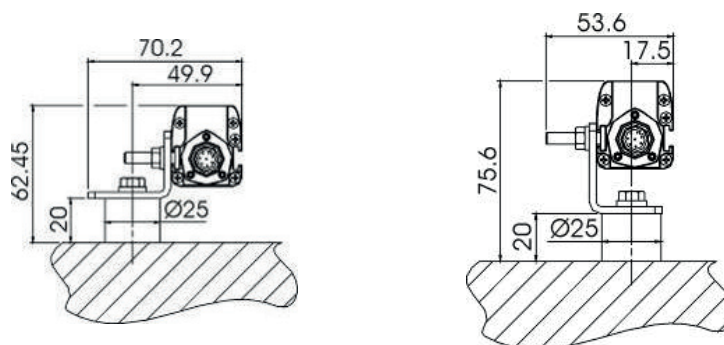

Angled fixing bracket + Adjustable support

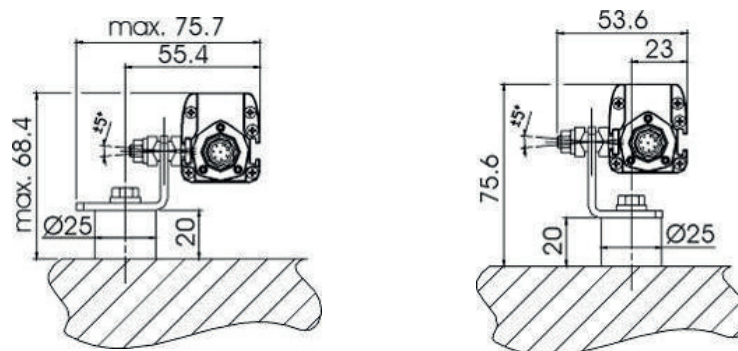

Angled fixing bracket + Adjustable support + Antivibration support



13.2. Test Pieces

Model	Description
SC TP14	Test Piece Ø 14mm L = 300mm
SC TP30	Test Piece Ø 30mm L = 300mm

13.3. Connection Cables



14. Glossary

ACTIVE OPTOELECTRONIC PROTECTIVE DEVICE (AOPD): its detection function is achieved thanks to the use of optoelectronic receivers and emitters detecting the optical beams interruptions inside the device caused by an opaque object present inside the specified detecting area.

An active optoelectronic protective device (AOPD) can operate both in emitter-receiver mode and in retro-reflective light curtains.

BLOCK CONDITION (=BREAK): status of the light curtain taking place when a suitably-sized opaque object (see DETECTING CAPACITY) interrupts one or several light curtain beams.

Under these conditions, OSSD1 and OSS2 light curtain outputs are simultaneously switched OFF within the device response time.

CONTROLLED MACHINE: machine having the potentially-dangerous points protected by the light curtain or by another safety system.

CROSSING HAZARD: situation under which an operator crossing the area controlled by the safety device and this latter stops and keeps the machine stopped until the hazard is eliminated, and then enters the dangerous area. Now the safety device could not be able to prevent or avoid an unexpected restart of the machine with the operator still present inside the dangerous area.

DANGEROUS AREA: area representing an immediate or imminent physical hazard for the operator working inside it or who could get in contact with it.

DETECTING CAPACITY (= RESOLUTION): limit of the parameter of the sensor function specified by the supplier, that will enable the electrosensitive protective equipment (ESPE). In case of an active optoelectronic protective device (AOPD), with resolution we mean the minimum dimension, which an opaque object must have in order to interrupt at least one of the beams that constitute the sensitive area.

ELECTROSENSITIVE PROTECTIVE EQUIPMENT (ESPE): assembly of devices and/or components working together to activate the protective disabling function or to detect the presence of something and including at least: a sensor, command/control devices and output signal switching devices.

EMITTER: unit emitting infrared beams, consisting of a set of optically-synchronised LEDs. The emitting unit, combined with the receiving unit (installed in the opposite position), generates an optical "curtain", i.e. the detecting area.

FINAL SWITCHING DEVICE (FSD): part of the control system connected to machine safety and breaking the circuit towards machine primary command element (MPCE) when the output signal switching device (OSSD) reaches the inactive condition.

MACHINE OPERATOR: qualified person authorised for machine use.

MACHINE PRIMARY COMMAND ELEMENT (MPCE): electrically-powered element having the direct control of machine regular operation so as to be the last element, in order of time, to operate when the machine has to be enabled or blocked.

MIN. INSTALLATION DISTANCE: min. distance necessary to allow machine dangerous moving parts to completely stop before the operator can reach the nearest dangerous point. This distance shall be measured from the middle point of the detecting area to the nearest dangerous point. The factors affecting min. installation distance value are: machine stop time, safety system overall response time, barrier resolution.

N.O.: normally opened

N.C.: normally closed

OFF STATUS: status when the output circuit is interrupted and does not allow current stream.

ON STATUS: status when the output circuit is operational and allows current stream.



OUTPUT SIGNAL SWITCHING DEVICE (OSSD): part of the electrosensitive protective equipment (ESPE) connected to machine control system that, when the sensor is triggered during standard operating mode, is switched to the inactive status.

PROTECTED AREA: area where a specified test object is detected by the ESPE.

PROTECTIVE DEVICE: device having the function to protect the operator against possible risks of injury due to the contact with machine potentially-dangerous parts.

QUALIFIED OPERATOR: a person who holds a professional training certificate or having a wide knowledge and experience and who is acknowledged as qualified to install and/or use of the product and to carry out periodical test procedures.

RECEIVER: unit receiving infrared beams, consisting of a set of optically-synchronised phototransistors. The receiving unit, combined with the emitting unit (installed in the opposite position), generates an optical "curtain", i.e. the detecting area.

RESPONSE TIME: max. time elapsing between the occurrence of the event leading to sensor activation and the reaching of the inactive state by the output signal switching device (OSSD).

RESTART INTERLOCK (= RESTART): device preventing machine automatic restart after sensor activation during a dangerous phase of machine operating cycle, after a change of machine operating mode, and after a variation in machine start control devices.

RISK: probability of occurrence of an injury and severity of the injury itself.

SAFETY LIGHT CURTAIN: it is an active optoelectronic protective device (AOPD) including an integrated system consisting of one or several emitting elements and one or several receiving elements forming a detection area with a detecting capacity specified by the supplier.

START INTERLOCK (= START): device preventing machine automatic start when the ESPE is powered, or when the power supply is cut and then restored.

TEST PIECE: opaque object having a suitable size and used to test safety light curtain correct operation.

TYPE (OF ESPE): the Electrosensitive Protective Equipment (ESPE) have different reactions in case of faults or under different environmental conditions. The classification and definition of the "type" (ex. type 2, type 4, according to IEC 61496-1) defines the minimum requirements needed for ESPE design, manufacturing and testing.

WORKING POINT: machine position where the material or semifinished product is worked.

OUR SALES NETWORK IN EUROPE

AUSTRIA - Carlo Gavazzi GmbH
Ketzergergasse 374, A-1230 Wien
Tel: +43 1 888 4112
Fax: +43 1 889 10 53
office@carlogavazzi.at

BELGIUM - Carlo Gavazzi NV/SA
Mechelsesteenweg 311, B-1800 Vilvoorde
Tel: +32 2 257 4120
Fax: +32 2 257 41 25
sales@carlogavazzi.be

DENMARK - Carlo Gavazzi Handel A/S
Over Hadstenvej 40, DK-8370 Hadsten
Tel: +45 89 60 6100
Fax: +45 86 98 15 30
handel@gavazzi.dk

FINLAND - Carlo Gavazzi OY AB
Petaksentie 2-4, FI-00661 Helsinki
Tel: +358 9 756 2000
Fax: +358 9 756 20010
myynti@gavazzi.fi

FRANCE - Carlo Gavazzi Sarl
Zac de Paris Nord II, 69, rue de la Belle
Etoile, F-95956 Roissy CDG Cedex
Tel: +33 1 49 38 98 60
Fax: +33 1 48 63 27 43
french.team@carlogavazzi.fr

GERMANY - Carlo Gavazzi GmbH
Pfnorstr. 10-14
D-64293 Darmstadt
Tel: +49 6151 81000
Fax: +49 6151 81 00 40
info@gavazzi.de

GREAT BRITAIN - Carlo Gavazzi UK Ltd
7 Springlakes Industrial Estate,
Deadbrook Lane, Hants GU12 4UH,
GB-Aldershot
Tel: +44 1 252 339600
Fax: +44 1 252 326 799
sales@carlogavazzi.co.uk

ITALY - Carlo Gavazzi SpA
Via Milano 13, I-20020 Lainate
Tel: +39 02 931 761
Fax: +39 02 931 763 01
info@gavazziacbu.it

NETHERLANDS - Carlo Gavazzi BV
Wijkmeerweg 23,
NL-1948 NT Beverwijk
Tel: +31 251 22 9345
Fax: +31 251 22 60 55
info@carlogavazzi.nl

NORWAY - Carlo Gavazzi AS
Melkeveien 13, N-3919 Porsgrunn
Tel: +47 35 93 0800
Fax: +47 35 93 08 01
post@gavazzi.no

PORTUGAL - Carlo Gavazzi Lda
Rua dos Jerónimos 38-B,
P-1400-212 Lisboa
Tel: +351 21 361 7060
Fax: +351 21 362 13 73
carlogavazzi@carlogavazzi.pt

SPAIN - Carlo Gavazzi SA
Avda. Iparraguirre, 80-82,
E-48940 Leioa (Bizkaia)
Tel: +34 94 480 4037
Fax: +34 94 480 10 61
gavazzi@gavazzi.es

SWEDEN - Carlo Gavazzi AB
V:a Kyrkogatan 1,
S-652 24 Karlstad
Tel: +46 54 85 1125
Fax: +46 54 85 11 77
info@carlogavazzi.se

SWITZERLAND - Carlo Gavazzi AG
Verkauf Schweiz/Vente Suisse
Sumpfstrasse 32,
CH-6312 Steinhausen
Tel: +41 41 747 4535
Fax: +41 41 740 45 40
info@carlogavazzi.ch

OUR SALES NETWORK IN AMERICA

USA - Carlo Gavazzi Inc.
750 Hastings Lane,
Buffalo Grove, IL 60089, USA
Tel: +1 847 465 6100
Fax: +1 847 465 7373
sales@carlogavazzi.com

CANADA - Carlo Gavazzi Inc.
2660 Meadowvale Boulevard,
Mississauga, ON L5N 6M6, Canada
Tel: +1 905 542 0979
Fax: +1 905 542 22 48
gavazzi@carlogavazzi.com

MEXICO - Carlo Gavazzi Mexico S.A. de C.V.
Calle La Montaña no. 28, Fracc. Los Pastores
Naucalpan de Juárez, EDOMEX CP 53340
Tel & Fax: +52.55.5373.7042
mexicosales@carlogavazzi.com

BRAZIL - Carlo Gavazzi Automação Ltda.
Avenida Brig. Luís Antônio, 3067
B. J. Paulista CEP 01401-000 São Paulo
Tel: +55 11 3052 0832
Fax: +55 11 3057 1753
info@carlogavazzi.com.br

OUR SALES NETWORK IN ASIA AND PACIFIC

SINGAPORE - Carlo Gavazzi Automation
Singapore Pte. Ltd.
61 Tai Seng Avenue
#05-06 UE Print Media Hub
Singapore 534167
Tel: +65 67 466 990
Fax: +65 67 461 980
info@carlogavazzi.com.sg

MALAYSIA - Carlo Gavazzi Automation
(M) SDN. BHD.
D12-06-G, Block D12,
Pusat Perdagangan Dana 1,
Jalan PJU 1A/46, 47301 Petaling Jaya,
Selangor, Malaysia.
Tel: +60 3 7842 7299
Fax: +60 3 7842 7399
sales@gavazzi-asia.com

CHINA - Carlo Gavazzi Automation
(China) Co. Ltd.
Unit 2308, 23/F.,
News Building, Block 1, 1002
Middle Shennan Zhong Road,
Shenzhen, China
Tel: +86 755 83699500
Fax: +86 755 83699300
sales@carlogavazzi.cn

HONG KONG - Carlo Gavazzi
Automation Hong Kong Ltd.
Unit 3 12/F Crown Industrial Bldg.,
106 How Ming St., Kwun Tong,
Kowloon, Hong Kong
Tel: +852 23041228
Fax: +852 23443689

OUR COMPETENCE CENTRES AND PRODUCTION SITES

Carlo Gavazzi Industri A/S
Hadsten - **DENMARK**

Carlo Gavazzi Ltd
Zejtun - **MALTA**

Carlo Gavazzi Controls SpA
Belluno - **ITALY**

Uab Carlo Gavazzi Industri Kaunas
Kaunas - **LITHUANIA**

Carlo Gavazzi Automation
(Kunshan) Co., Ltd.
Kunshan - **CHINA**

HEADQUARTERS

Carlo Gavazzi Automation SpA
Via Milano, 13 - I-20020
Lainate (MI) - **ITALY**
Tel: +39 02 931 761
info@gavazziautomation.com



CARLO GAVAZZI
Automation Components
Energy to Components!

www.gavazziautomation.com

