

VariFlex²

RVEF series

Quick Start Guide

110V Class 1ph	0,20~0,75kW 0,2~1HP
220V Class 1ph or 3ph	0,2~2.2kW 0,2~3HP
440V Class 3ph	0,75~2,2kW 1~3HP





General Information

The manufacturer accepts no liability for any consequences resulting from inappropriate, negligent or incorrect installation or adjustment of the optional parameters of the equipment or from mismatching the variable speed drive with the motor.

The contents of this guide are believed to be correct at the time of printing. In the interests of commitment to a policy of continuous development and improvement, the manufacturer reserves the right to change the specification of the product or its performance, or the content of the guide without notice.

All rights reserved. No parts of this guide may be reproduced or transmitted in any form or by any means, electrical or mechanical including, photocopying, recording or by an information storage or retrieval system, without permission in writing from the publisher.

Drive Software Version

This product is supplied with the latest version of user-interface and machine control software.

This product is to be used in a new or existing system with other drives, there may be differences between their software and the software in this product. These differences may the product to function differently. This may also apply to drives returned from the Carlo Gavazzi Service Centre.

If there is any doubt, please contact your local Carlo Gavazzi representative or Distributor.

Environmental Statement

The electronic variable speed drives have the potential to save energy and (through increased machine/process efficiency) reduce raw material consumption and scrap throughout their long working lifetime. In typical applications, these positive environmental effects far outweigh the negative impacts of product manufacture and end-of-life disposal.

Nevertheless, when the products eventually reach the end of their useful life, they can very easily be dismantled into their major component parts for efficient recycling. Many parts snap together and can be separated without the use of tools, while other parts are secured with conventional screws.

Virtually all parts of the product are suitable for recycling.

Product packaging is of good quality and can be re-used. All the products come in strong cardboard cartons which themselves have a high recycled fibre content. If not re-used, these containers can be recycled. Polythene, used on the protective film and bags from wrapping product, can be recycled in the same way. Carlo Gavazzi packaging strategy favours easily recyclable materials of low environmental impact, and regular reviews identify opportunities for improvement.

When preparing to recycle or dispose of any product or packaging, please observe local legislation and best practice.



Quick Start guide

This guide is to assist in installing and running the inverter to verify that the drive and motor are working properly. Starting, stopping and speed control will be from the keypad. If your application requires external control or special system programming, consult the RVEF instruction manual supplied with your inverter.

Step 0 Products inspection

Carlo Gavazzi's inverters are all passed the function test before delivery. Please check the followings when you received and unpacked the inverter:

- The model and capacity of the inverter are the same as those specified in your purchase order.
- Check where there are any damages caused by transportation. Please do not apply the power, and do contact Carlo Gavazzi's sales representatives if any of the above problems happened.

Step 1 Before starting the inverter

Please review Introduction and Safety Precautions of the RVEF Instruction Manual. Verify drive was installed in accordance with the procedures as described in this manual. If you feel this was abnormal, do not start the drive until qualified personnel have corrected the situation. (Failure to do so could result in serious injury.)

- **Check inverter and motor nameplates to determine that they have the same HP and voltage ratings. (Ensure that full load motor amps do not exceed that of the inverter.)**
- **Remove the terminal cover to expose the motor and power terminals.**
 - a. **Verify that AC power is wired to L1, L2, and L3.**
 - b. **Verify that Motor leads are connected to T1, T2, and T3. (The two leads may need to be reversed if motor rotation is not correct).**
 - c. **If brake module is necessary, please connect terminal voltage of the braking unit to + and - of the inverter.**

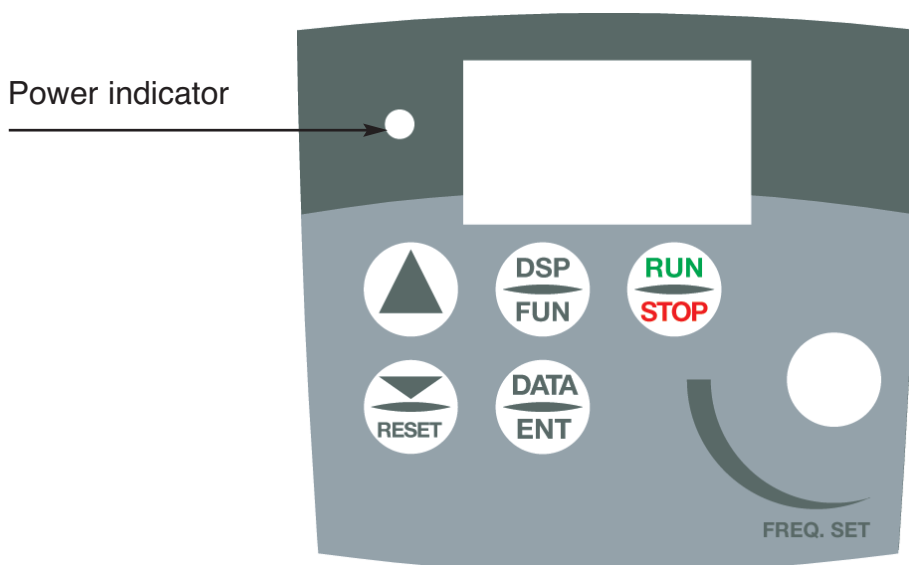

Step 2 Apply power to the drive.

- Apply AC power to the drive and observe operator. Three 7-segment display should show power voltage for 3~5 seconds and then show Frequency Command, factory sets 5.00. Frequency Command of 7-segment display should be flashed all the time.



Step 3 Check motor rotation without load.

- Press RUN Key. 7-segment Display will indicate 00.0 to 05.0. Such value is the frequency output value.
- Check motor rotation. If the direction of the motor is incorrect:
Press STOP Key, turn off the AC power supply. After Power indicator LED is off, change over the T1 and T2. Supply the power again, then check the motor direction.
- Press STOP key to stop the drive.

Step 4 Check full speed at 50Hz/60Hz

- Change the frequency with ▲ ▼ arrow mark, please press DATA/ENTER after setting frequency.
- Set frequency to 50Hz/60Hz according to the above regulations.
- Press RUN Key, check drive acceleration to full speed.
- Press STOP Key, to stop drive and check deceleration.

Step 5 Other settings

Please refer to the following page:

Set acceleration time	pag. 38
Set deceleration time	pag. 38
Set upper frequency limit	pag. 40
Set lower frequency limit	pag. 40
Set motor rated current	pag. 50
Set control mode (Sensorless, V/F)	pag. 54

Step 6 Sensorless mode setting

When the RVEF inverter is set to run in Sensorless Mode (C14=000), the motor parameters need to be set. The required information should be readily available on the nameplate of the motor (0.75 kW=1HP).

The parameters to set for sensorless operation are:

Motor Rated Current (Amps) (F43)	pag. 50
Motor Rated Voltage (Volts) (F44)	pag. 50
Motor Rated Frequency (Hz) (F45)	pag. 50
Motor Rated Power (kW) (F46)	pag. 50
Motor Rated Speed (RPM) (F47)	pag. 50

Additional Sensorless Mode Settings to adjust for optimum operations are:

Torque boost gain (F48)	pag. 50
Slip compensation gain (F49)	pag. 51
Low Frequency Voltage Compensation (F50)	pag. 52



CONTENTS

Quick Start Guide	2
Contents	4
Introduction	5
i.1 Model Description	5
i.2 Type Selection	6
i.3 Electrical Safety - general warning	6
i.4 System design and safety of personnel	6
i.5 Environmental Limits	7
i.6 Access	7
i.7 Compliance and regulations	7
i.8 Motor	7
i.9 Adjusting parameters	8
i.10 Electrical installation	8
i.10.1 Electric shock risk	8
i.10.2 Isolation device	8
i.10.3 STOP function	8
i.10.4 Stored charge	8
i.10.5 Equipment supplied by plug and socket	8
i.10.6 Ground leakage current	9
Chapter 1 Notice for wiring	10
1.1 Fuse types	10
1.2 Precautions for peripheral applications	12
1.3 RVCF Wiring diagram	13
1.4 Descriptions of Inverter terminal	15
1.5 Dimensions	17
Chapter 2 Software index	19
2.1 Operation Instruction of the keypad	19
2.2 Control Mode Selection	20
2.3 Programmable function list	21
Chapter 3 Troubleshooting and maintenance	36
3.1 Error display and remedy	36
3.1.1 Error which can not be recovered manually	36
3.1.2 Error which can be recovered manually and automatically	37
3.1.3 Error which can be recovered manually but not automatically	38
3.1.4 Special conditions	39
3.1.5 Operation errors	40
3.2 General functional troubleshooting	41
Appendix 1 : RVEF parameter setting list	42
Appendix 2 : CE Certificate	43
Appendix 3 : APPROVALS Table UL listing and CE Certification	44

Chapter 2

Model description



2.1 Label description

⚠ CAUTION

Do not inspect components unless the lamp is off.
See manual for proper installation and operation.

Model : RVEFB340220
Motor Rating : 3HP/2.2kW

INPUT : AC 3 phases 50/60Hz
VOLTAGE : 380~480V (+10%, -15%)
Amps : 6.6A

OUTPUT : AC 3 phases 0~650Hz
VOLTAGE : 0~480V
Amps : 5.2A

IP20 / UL Open-Type with shielding cover removed
(rated - 10°C to 50°C Ambient).
NEMA 1/ UL Type 1 with shielding cover and optional
conduit box kit installed (rated -10°C to 40°C Ambient).



LISTED xxxx
POWER CONV. EQ.
E319186





Carlo Gavazzi
Via Milano 13, IT-20020 Lainate (MI)

Made in: CHINA

← Inverter model

← Input power

← Output power

2.2 Ordering Key

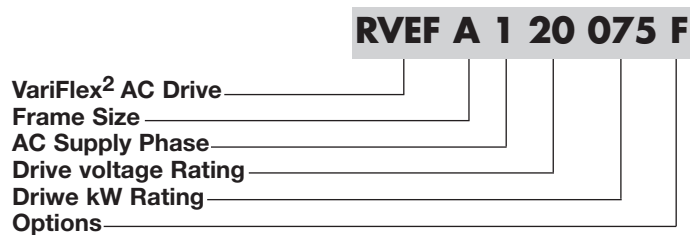



i.2 Type Selection

Voltage rating	Output voltage	Motor size		Model	Dimension
		kW	HP		
100-120VAC (+10% -15%) 1-Phase	0÷240V 3-Phase 0.1÷200Hz	0.20	0.25	RVEFA110020	A
		0.40	0.50	RVEFA110040	A
		0.75	1.0	RVEFA110075	A
200-240VAC (+10% -15%) 1-Phase		0.20	0.25	RVEFA120020(F)	A
		0.40	0.50	RVEFA120040(F)	A
		0.75	1.0	RVEFA120075(F)	A
200-240VAC (+10% -15%) 3-Phase		1.5	2.0	RVEFB120150(F)	B
		2.2	3.0	RVEFB120220(F)	B
		0.20	0.25	RVEFA320020	A
		0.40	0.50	RVEFA320040	A
		0.75	1.0	RVEFA320075	A
380-480VAC (+10% -15%) 3-Phase		1.5	2.0	RVEFB320150	B
	2.2	3.0	RVEFB320220	B	
	0.75	1.0	RVEFB340075	B	
	0÷480V 3-Phase 0.1÷200Hz	1.5	2.0	RVEFB340150	B
		2.2	3.0	RVEFB340220	B

i.3 Electrical Safety - general warning

The voltages used in the drive can cause severe electrical shock and/or burns, and could be lethal. Extreme care is necessary at all times when working with or adjacent to the drive. Specific warnings are given at the relevant places in this guide.

i.4 System design and safety of personnel

The drive is intended as a component for professional incorporation into complete equipment or system. If installed incorrectly, the drive may present a safety hazard.

The drive uses high voltages and currents, carries a high level of stored electrical energy, and is used to control equipment which can cause injury. System design, installation, commissioning and maintenance must be carried out by personnel who have the necessary training and experience. They must read this safety information and this guide carefully.

The STOP and START controls or electrical inputs of the drive must not be relied upon to ensure safety of personnel. They do not isolate dangerous voltages from the output of the drive or from any external option unit. The supply must be disconnected by an approved electrical isolation device before gaining access to the electrical connections.

The drive is not intended to be used for safety-related functions.

Careful consideration must be given to the function of the drive which might result in a hazard, either through its intended behaviour or through incorrect operation due to a fault. In any application where a malfunction of the drive or its control system could lead to or allow damage, loss or injury, a risk analysis must be carried out, and where necessary, further measures taken to reduce the risk - for example, an over-speed protection device in case of failure of the speed control, or a fail-safe mechanical brake in case of loss of motor braking.



i.5 Environmental Limits

Instructions within the supplied data and information within the *VariFlex² Advanced User Manual* regarding transport, storage, installation and the use of the drive must be complied with, including the specified environmental limits. Drives must not be subjected to excessive physical force.

i.6 Access

Access must be restricted to authorised personnel only. Safety regulations which apply at the place of use must be complied with.

The IP (Ingress Protection) rating of the drive is installation dependant. For further information, refer to the *VariFlex² Advanced User Manual*.

i.7 Compliance and regulations

The installer is responsible for complying with all relevant regulations, such as national wiring regulations, accident prevention regulations and electromagnetic compatibility (EMC) regulations. Particular attention must be given to the cross-sectional areas of conductors, the selection of fuses and other protection, and protective earth (ground) connections.

The *VariFlex² Advanced User Manual* contains instructions for achieving compliance with specific EMC standards.

Within the European Union, all machinery in which this product is used must comply with the following directives:

98/37/EC: Safety of machinery

89/336/EEC: Electromagnetic compatibility

i.8 Motor

Ensure the motor is installed in accordance with the manufacturer's recommendations.

Ensure the motor shaft is not exposed. Standard squirrel cage induction motors are designed for single speed operation. If it is intended to use the capability of a drive to run a motor at speeds above its designed maximum, it is strongly recommended that the manufacturer is consulted first.

Low speeds may cause the motor to overheat because the cooling fan becomes less effective. The motor should be fitted with a protection thermistor. If necessary, an electric force vent fan should be used. The values of the motor parameters set in the drive affect the protection of the motor. The default values in the drive should not be relied upon. It is essential that the correct value is entered into parameter concerning the motor rated current. This affects the thermal protection of the motor.

i.9 Adjusting parameters

Some parameters have a profound effect on the operation of the drive. They must not be altered without careful consideration of the impact on the controlled system.

Measures must be taken to prevent unwanted changes due to error or tampering.



i.10 Electrical installation

i.10.1 Electric shock risk

The voltages present in the following locations can cause severe electric shock and may be lethal:

- AC supply cables and connections
- DC bus, dynamic brake cables and connections
- Output cables and connections
- Many internal parts of the drive, and external option units

Unless otherwise indicated, control terminals are single insulated and must not be touched.

i.10.2 Isolation device

The AC supply must be disconnected from the drive using an approved isolation device before any cover is removed from the drive or before any servicing work is performed.

i.10.3 STOP function

The STOP function does not remove dangerous voltages from the drive, the motor or any external option units.

i.10.4 Stored charge

The drive contains capacitors that remain charged to a potentially lethal voltage after the AC supply has been disconnected. If the drive has been energised, the AC supply must be isolated at least ten minutes before work may continue.

Normally, the capacitors are discharged by an internal resistor. Under certain, unusual fault conditions, it is possible that the capacitors may fail to discharge, or be prevented from being discharged by a voltage applied to the output terminals. If the drive has failed in a manner that causes the display to go blank immediately, it is possible the capacitors will not be discharged. In this case, consult Carlo Gavazzi or their authorised distributor.

i.10.5 Equipment supplied by plug and socket

Special attention must be given if the drive is installed in equipment which is connected to the AC supply by a plug and socket. The AC supply terminals of the drive are connected to the internal capacitors through rectifier diodes which are not intended to give safety isolation. If the plug terminals can be touched when the plug is disconnected from the socket, a means of automatically isolating the plug from the drive must be used (e.g. a latching relay).

i.10.6 Ground leakage current

The drive is supplied without or with an internal EMC filter capacitor fitted. If the input voltage to the drive is supplied through an ELCB or RCD, these may trip due to the ground leakage current. Please refer to *VariFlex² Advanced User Manual* for further information and how to connect correctly the EMC capacitor.

Chapter 1:

Notice for Wiring

1.1 Fuse types

Drive input fuses are provided to disconnect the drive from power in the event that a component fails in the drive's power circuitry. The drive's electronic protection circuitry is designed to clear drive output short circuits and ground faults without blowing the drive input fuses. Below table shows the RVEF input fuse ratings. To protect the inverter most effectively, use fuses with current-limit function (RK5, CC/T type fuse for RVEF).

Model	Motor Rating		Max Fuse Rating (A)	
	kW	HP	RK5 fuse	CC or T fuse
RVEFA110020	0.20	0.25	10	20
RVEFA110040	0.40	0.50	15	30
RVEFA110075	0.75	1.0	20	40
RVEFA120020	0.20	0.25	8	15
RVEFA120040	0.40	0.50	10	20
RVEFA120075	0.75	1.0	15	30
RVEFB120150	1.5	2.0	20	40
RVEFB120220	2.2	3.0	25	50
RVEFA320020	0.20	0.25	5	8
RVEFA320040	0.40	0.50	8	10
RVEFA320075	0.75	1.0	12	15
RVEFB320150	1.5	2.0	15	20
RVEFB320220	2.2	3.0	20	30
RVEFB340075	0.75	1.0	6	10
RVEFB340150	1.5	2.0	10	15
RVEFB340220	2.2	3.0	10	20

Notice

- To avoid shock hazards, do not touch any electrical component when the power is applied or just after five minutes the power plug is unplugged. The other action should be performed after the charge indicator went off.
- Do not perform wiring on the inverter while it is still electrified. Disregard of this notice could cause serious injury or death to persons.

This product is designed to use in Pollution Degree 2 environment or equivalent environments.

* Fuse ratings are based upon 300V fuses for 230V inverter, and 500V for 480V inverters.

1.2 Precautions for Peripheral Applications:

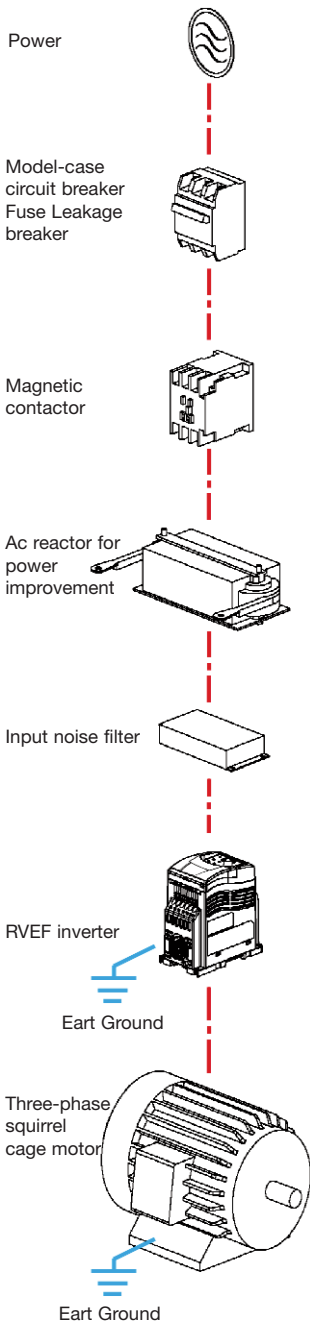

Power supply:

- Make sure the voltage applied is correct to avoid damaging the inverter.
- A molded-case circuit breaker must be installed between the AC source and the inverter.

Molded-case circuit breaker:

- Use a molded-case circuit breaker that conforms to the rated voltage and current of the inverter to control the power ON/OFF and protect the inverter.
- Do not use the inverter as the switch for run/stop switch.

Leakage breaker:

- Install a leakage breaker to prevent error operation caused by electric leakage and to protect operators.
- Setting current should be 200mA or above and the operating time at 0.1 second or longer to prevent malfunction.

Magnetic contactor:

- Normal operations do not need a magnetic contactor. But a contactor has to be installed in primary side when performing functions such as external control and auto restart after power failure, or when using brake controller.
- Do not use the magnetic contactor as the run/stop switch of the inverter.

AC reactor for power improvement:

- When inverters are supplied with high capacity (above 600kVA) power source, an AC reactor can be connected to improve the power performance.

Install fast action fuse:

- To ensure the safety of peripheral devices, please install the fast action fuse. Regarding the specification, please refer to pag 17.

Input noise filter:

- A filter must be installed when there are inductive load around the inverter.

Inverter:

- Input power terminals L1, L2, and L3 can be used in any sequence regardless of phases.
- Output terminals T1, T2, and T3 are connected to U, V, and W terminals of the motor. If the motor is reversed while the inverter is forward, just swap any two terminals of T1, T2, and T3.
- To avoid damaging the inverter, do not connect the input terminals T1, T2, and T3 to AC power.
- Connect the ground terminal properly. Class 240V: $R_g < 100\Omega$; Class 480V: $R_g < 10\Omega$.

1.3 RVEF Wiring Diagram

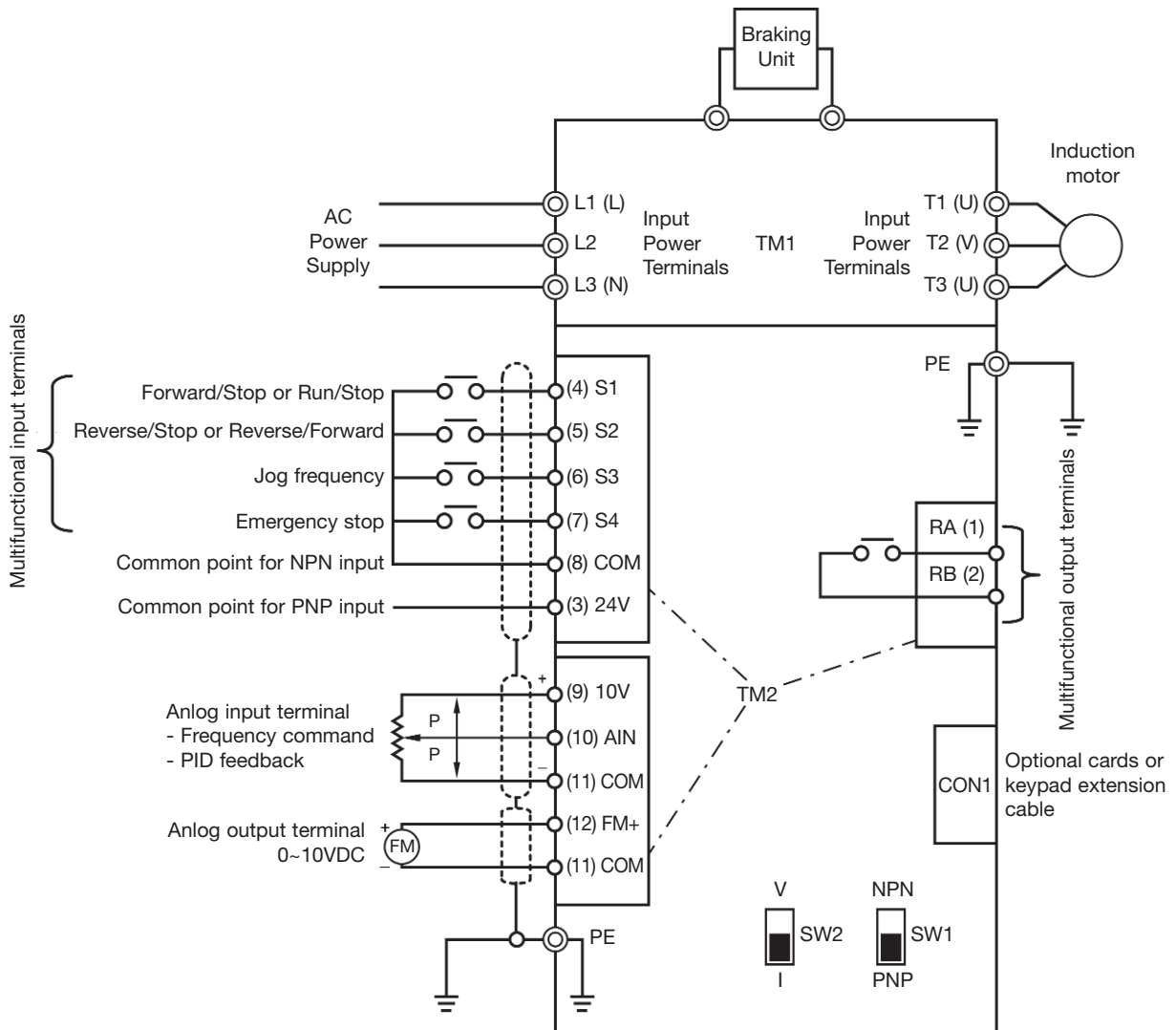

- Note 1: connect inputs to terminal 3 (internal 24VDC) for PNP mode (positive switching) or to terminal 8 (common) for NPN mode (negative switching).
- Note 2: external 24 VDC may be used to supply the external contacts at each input; connect the 0V of the external supply to common (terminal 8).

Example: Main circuit wiring diagram

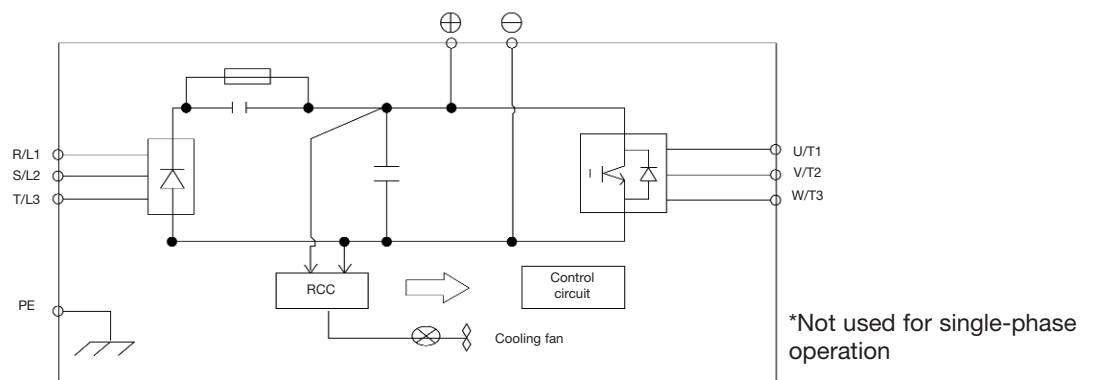



1.4 Description of Inverter Terminal

Description of power terminals

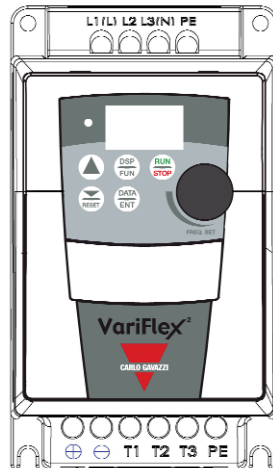
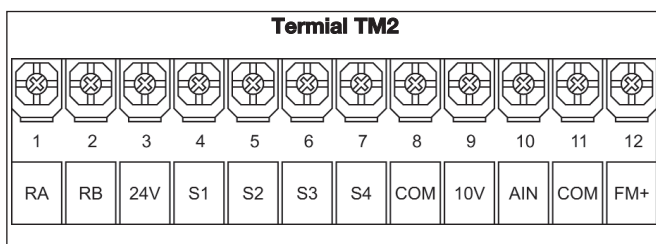
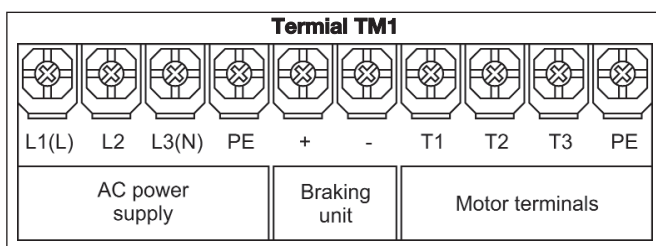

Figure 3-15 Power terminals locations

Supply terminal	
1-phase	L1, L3(N)
3-phase	L1, L2, L3
Motor terminal	T1, T2, T3
Multifunctional input terminal	
Input terminal	S1~S4 (and AIN: high level >8V, low level <2V).
Common terminal	
24V	PNP input.
COM	NPN input.
External terminal	Supply the input terminal with external 24VDC and connect the 0V of the external supply to COM terminal.

Multifunctional output terminal	
RA, RB	NO relay contact.
Analog input terminal	
Input terminal	AIN
Common terminal	COM
Analog output terminal	
Output terminal	FM+
Common terminal	COM
Additional terminals	T+, T- with an optional card.
Braking unit	
Terminals	+, -



	SW1	SW2
	NPN input	0~10VDC analog signal
	PNP input	4~20mA analog signal

* Braking units are required for applications where a load with high inertia needs to be stopped rapidly.

Use a power-matched braking unit and resistor to dissipate the energy generated by the load while stopping. Otherwise inverter will trip on over voltage.

* Terminal at L2 will be non-functional for single-phase units.

1.5 Dimension

- (1) Size A:** Single phase: RVEFA110020, RVEFA110040, RVEFA110075,
RVEFA120020(F), RVEFA120040(F), RVEFA120075(F)
Three phase: RVEFA320020, RVEFA320040, RVEFA320075

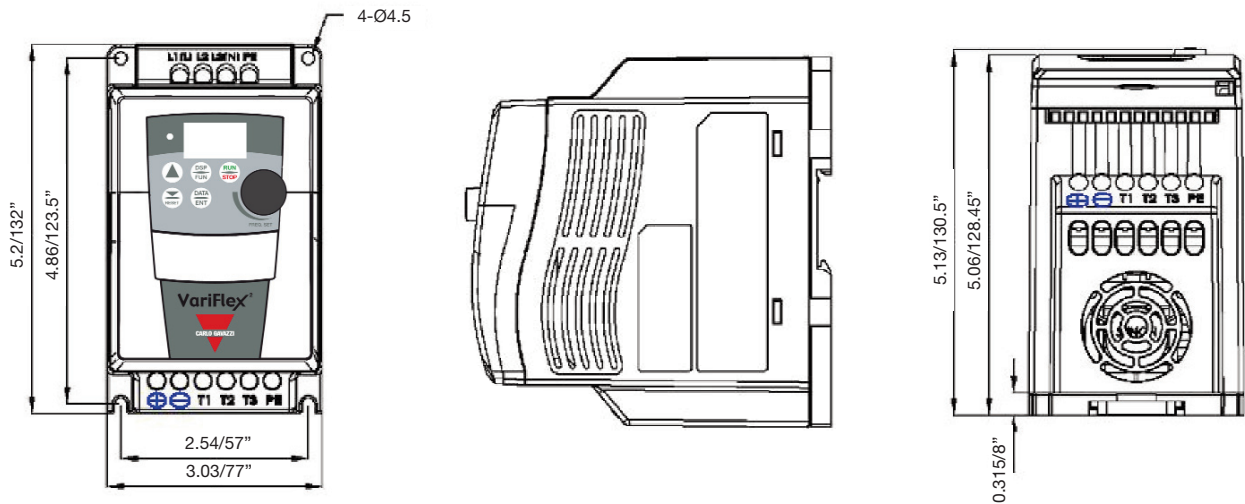

Figure 3-17 RVEF drive size A

- (2) Size B:** Single phase: RVEFB120150(F), RVEFB120220(F)
Three phase: RVFEB320150, RVFEB320220
Three phase: RVFEB340075(F), RVFEB340150(F), RVEFB120220(F)

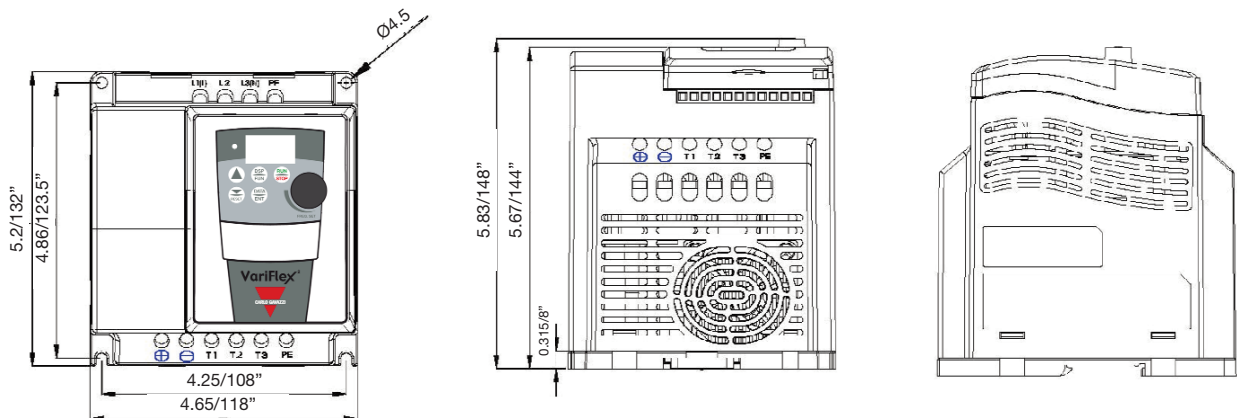

Figure 3-18 RVEF drive size B

Net Weight kg	RVEFA110020	RVEFA110040	RVEFA110075	RVEFA120020(F)	RVEFA120040(F)	RVEFA120075(F)
	0.62	0.68	0.72	0.65(0.71)	0.67(0.73)	0.67(0.73)
	RVEFB120150(F)	RVEFB120220(F)	RVEFA320020	RVEFA320040	RVEFA320075	RVEFB320150
	1.00(1.25)	1.05(1.3)	0.61	0.61	0.66	0.95
	RVEFB320220	RVEFB340075(F)	RVEFB340150(F)	RVEFB340220(F)	-	-
	1.00	1.5(1.68)	1.52(1.7)	1.55(1.74)	-	-

1.6 Installation and Design Consideration

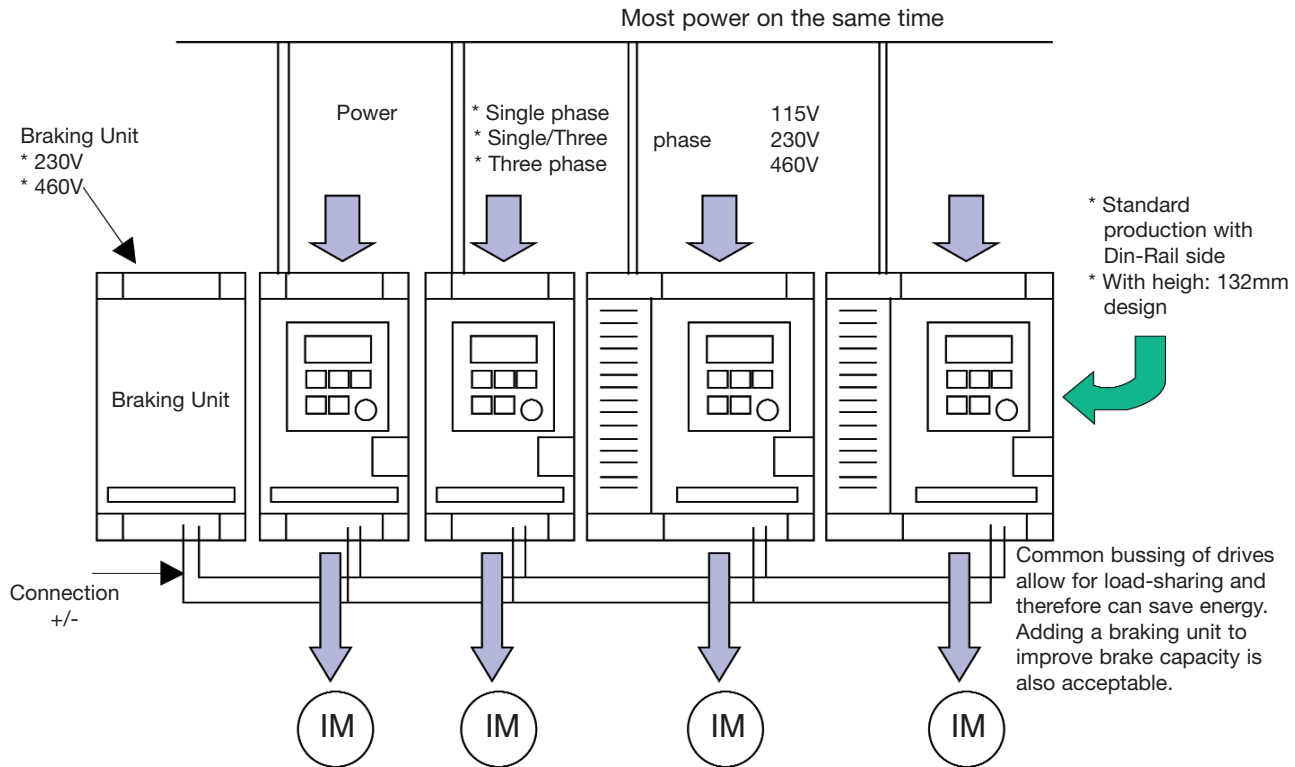
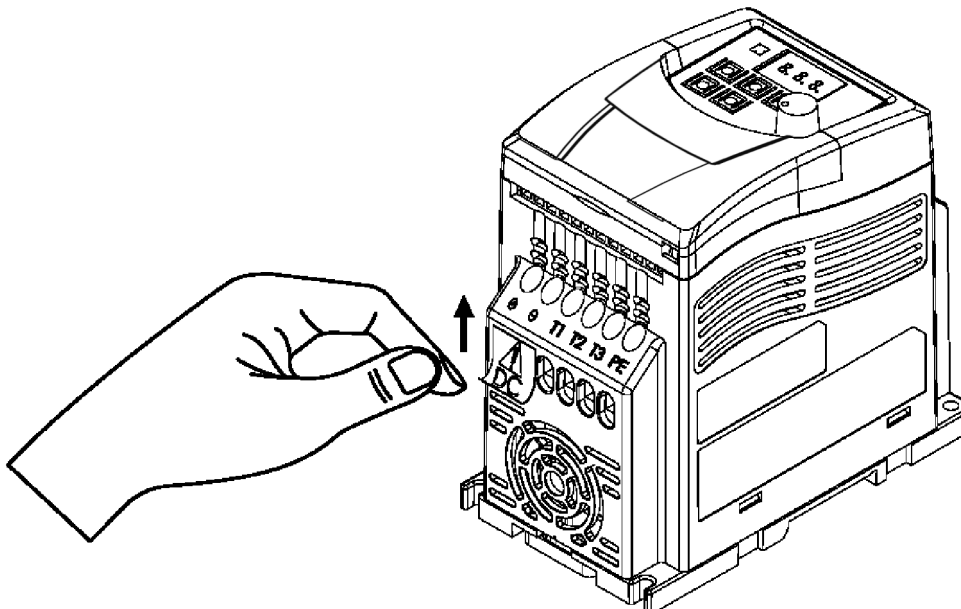

Figure 3-21 Common bus configurations

- Note 1. Common bus connections from a common input power supply as shown above.
- Note 2. When connecting a drive or drives' DC bus connections in parallel with larger. Hp rated drives, use a magnetic contactor with the "+" & "-" terminals, otherwise, inverter damage can result.

Note: if terminal block be used, please take off the TB label as shown below.



- **Connection & EMC Mounting (for drivers with built-in filter):**

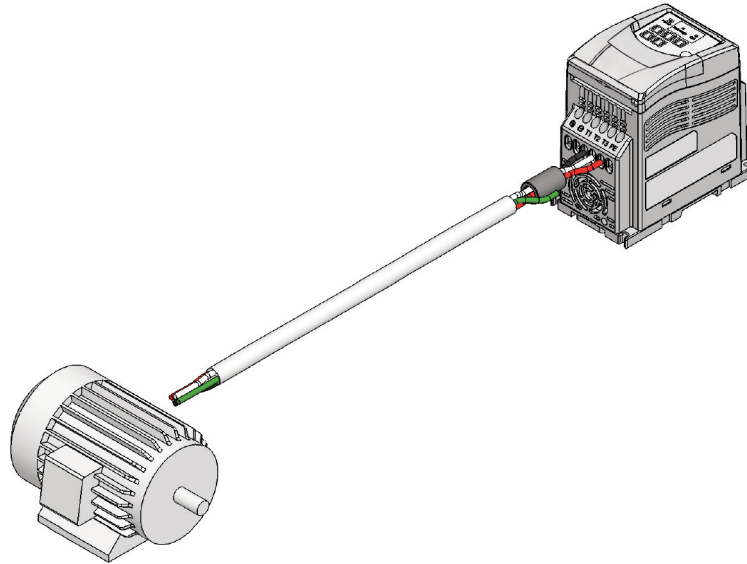

NOTE:

For 0.20~0.75 kW filter models, additional items will be found inside the box including: [1] pc of EMC conformed waterproof (IP65) ferrite core.



Caution

If application requires to meet EMC regulation, you **MUST** first let the ferrite core through the motor cables, then constrain the motor cable on the inverter as stated in the above diagram. Please also note the length of the motor cable **CANNOT** exceed 5m under EMC regulation.

Chapter 2

Programming instructions & Parameter list



2.1 Keypad description

2.1.1 Keypad display and operation instruction

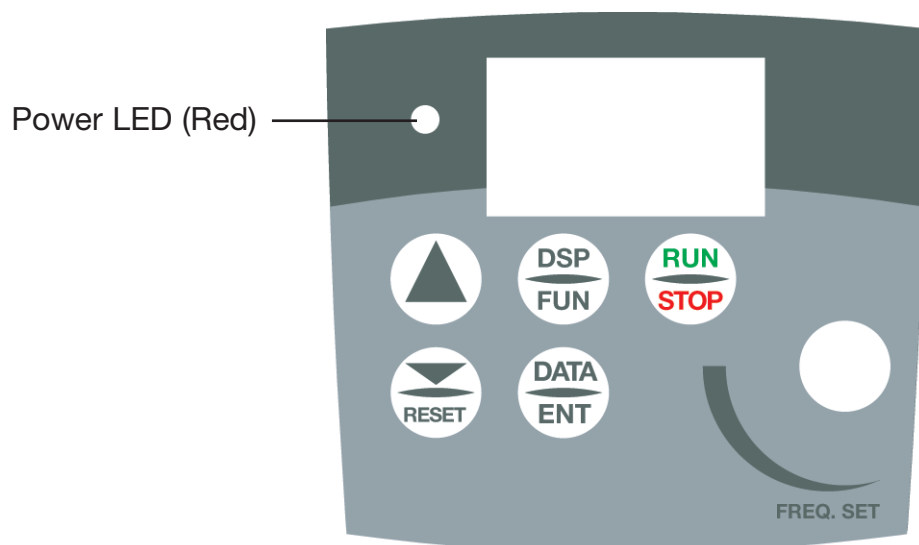

Figure 4-1 Keypad layout

Remote/Local change function

• Local mode

- Run command via **RUN/STOP** key on the keypad
- Frequency command
 - When C41=000: only UP/DOWN key on the keypad can control and F05 setting has no effect.
 - When C41=001: only VR on the keypad can control and F05 setting has no effect.

• Remote mode

- Run command from run parameter (**F04**) control setting
- Frequency command from Frequency parameter (**F05**) control setting

Remote/Local change mode on keypad is achieved by simultaneously pressing RESET and DATA/ENT. Each successive operation toggles between local and remote. Note: the inverter must be stopped.

2.1.2 Operation Instruction of the Keypad

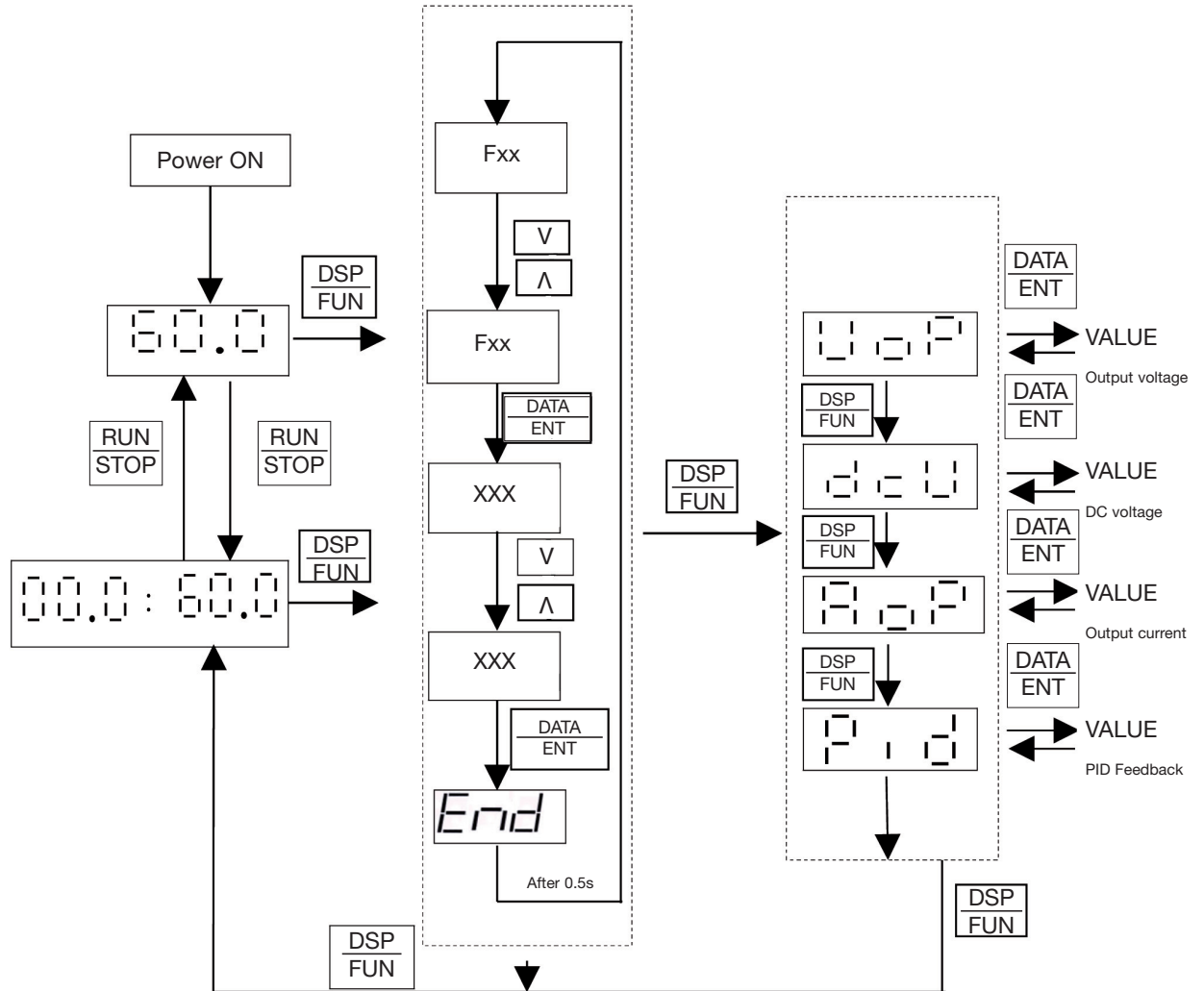

Figure 4-2 Keypad Operations Sequence

*1: Display flashes with set frequency in stop mode, but it is solid in run mode.

*2: The frequency can be set during both stop and run modes.

*3: Output voltage, DC voltage, Output current and PID feedback is displayed when F10=001.



4.2 Parameter Function List

Basic parameter function list

F	Function Description Factory	Range/ Code	Factory Default	Remarks
F00	Inverter horse power capacity			
F01	Acceleration time #1 (s)	00.1~999	05.0	*1 *2
F02	Deceleration time #1 (s)	00.1~999	05.0	*1 *2
F03	Motor rotation direction	000: Forward 001: Reverse	000	*1
F04	Run command source	000: Keypad 001: External terminals (TM2) 002: Communication control	000	
F05	Frequency command source	000: Up/Down keypad 001: Potentiometer on keypad 002: AIN input signal (TM2) 003: Multifunction input terminals UP/DOWN function 004: Communication control	000	
F06	External control operation mode	000: Forward/Stop - Reverse/Stop 001: Run/Stop - Forward/Reverse 002: 3-wires control mode Run/Stop	000	
F07	Frequency upper limit (Hz)	01.0 ~200	50.0/60.0	*2
F08	Frequency lower limit (Hz)	00.0 ~200	00.0	*2
F09	Stopping method	000: Decelerate to stop 001: Coast to stop	000	*1
F10	Status display parameters	000: No display 001: Display	000	*1
F11	Multifunction input terminal S1	000: Forward/stop command 001: Reverse/stop command 002: Preset speed command #1 003: Preset speed command #2 004: Preset speed command #3 005: Jog frequency command 006: Emergency stop (E.S.) 007: Base Block (b.b.) 008: Use accel / decel time #2 009: Reset 010: Up command 011: Down command 012: Control signal switch 013: Communication control signal switch	000	
F12	Multifunction input terminal S2	014: Acceleration/deceleration inhibition	001	
F13	Multifunction input terminal S3	015: Master/Auxiliary speed source select	005	
F14	Multifunction input terminal S4	016: PID function disable	006	
F15	Multifunction input terminal AIN	017: Analog frequency signal input (terminal AIN) 018: PID feedback signal (terminal AIN) 019: DC Brake signal *6	017	
F16	AIN signal select	000: 0 ~10V (0~20mA) 001: 4~20mA (2~10V)	000	
F17	AIN Gain (%)	000~200	100	
F18	AIN Bias (%)	000~100	000	*1
F19	AIN Bias selection	000: Positive 001: Negative	000	
F20	AIN Slope Direction	000: Positive 001: Negative	000	*1



F	Function Description Factory	Range/ Code	Factory Default	Remarks
F21	Multifunction output RA/RB	000: Run 001: Frequency reached (set frequency \pm F23) 002: Frequency is within the range set by (F22 \pm F23) 003: Frequency detection (>F22) 004: Frequency detection (<F22) 005: Fault conditions 006: Auto reset and restart 007: Momentary power loss 008: Emergency Stop (E.S.) 009: Base Block (b.b.) 010: Motor overload protection 011: Inverter overload protection 012: Retain 013: Power on 014: Communication error 015: Output current detection (>F24)	000	
F22	Frequency detection set-point (Hz)	00.0~200	000	*1
F23	Frequency detection range (\pm Hz)	00.0~30.0	00.0	*1
F24	Output current set-point (%)	000~100	000	
F25	Output current detection time (s)	00.0~25.5	00.0	
F26	Multifunction analog output type selection	000: Output frequency 001: Set frequency 002: Output voltage 003: DC voltage 004: Output current 005: PID feedback signal	000	*1
F27	Multifunction analog output gain (%)	000~200	100	*1
F28	Preset frequency n°1 (Main frequency setting) (Hz)	00.0~200	05.0	*1
F29	Preset frequency n°2 (Hz)	00.0~200	05.0	*1
F30	Preset frequency n°3 (Hz)	00.0~200	10.0	*1
F31	Preset frequency n°4 (Hz)	00.0~200	20.0	*1
F32	Preset frequency n°5 (Hz)	00.0~200	30.0	*1
F33	Preset frequency n°6 (Hz)	00.0~200	40.0	*1
F34	Preset frequency n°7 (Hz)	00.0~200	50.0	*1
F35	Preset frequency n°8 (Hz)	00.0~200	60.0	*1
F36	Jog frequency instruction (Hz)	00.0~200	05.0	*1
F37	DC braking time (s)	00.0~25.5	00.5	
F38	DC braking start frequency (Hz)	01.0~10.0	01.5	
F39	DC braking level (%)	000~020	005	
F40	Carrier frequency (kHz)	004~016	010	4~15k
F41	Auto restart on momentary power loss	000: Enable 001: Disable	001 *6	
F42	Auto restart times	000~005	000	
F43	Motor rated current (A)	— — — — — — — — — — — — — — — —	*4	
F44	Motor rated voltage (V)	— — — — — — — — — — — — — — — —	*4	
F45	Motor rated frequency (Hz)	— — — — — — — — — — — — — — — —	*4	
F46	Motor rated power (kW)	— — — — — — — — — — — — — — — —	*4	
F47	Motor rated speed (RPM/100)	0~120 *8	*4	



F	Function Description Factory	Range/ Code	Factory Default	Remarks
F48	Torque Boost Gain (sensorless) (%)	001~450		
F49	Slip compensation gain (sensorless) (%)	001~450		
F50	Low frequency voltage compensation	000~40		
F51	Advanced parameter function display	000: Don't display 001: Display	000	*1
F52	Factory default	010: Reset to factory default (50Hz) 020: Reset to factory default (60Hz)	000	
F53	Software version	CPU Version		*3 *4
F54	Latest 3 fault records	— — — — — — — — — —		*3 *4

Advanced function parameter list (Enable access to these parameters by setting F51=001)

C	Function Description	Range/ Code	Factory Default	Remarks
C00	Reverse run	000: Reverse enable 001: Reverse disable	000	
C01	Acceleration stall prevention	000: Enable stall prevention during acceleration 001: Disable stall prevention during acceleration	000	
C02	Acceleration stall prevention level (%)	050~300	200	
C03	Deceleration stall prevention	000: Enable stall prevention during deceleration 001: Disable stall prevention during deceleration	000	
C04	Deceleration stall prevention level (%)	050~300	200	
C05	Run stall prevention	000: Enable stall prevention in run mode 001: Disable stall prevention in run mode	000	
C06	Run stall prevention level (%)	050~300	200	
C07	Stall prevention time during run	000: according to decel time set in F02 001: according to decel time set in C08	000	
C08	Stall prevention deceleration time (s)	00.1~999	03.0	
C09	Direct start on power up	000: Enable direct start on power up 001: Disable direct start on power up	001	
C10	Reset mode	000: Reset is enable when RUN switch is OFF 001: Reset is enable with RUN switch OFF or ON	000	
C11	Acceleration time #2 (s)	00.1~999	05.0	*1 *2
C12	Deceleration time #2 (s)	00.1~999	05.0	*1 *2
C13	Fan control	000: Auto-run by temperature 001: Run when inverter runs 002: Always run 003: Always stop	001	
C14	Control mode	000: Sensorless control 001: V/F Control	000	*4
C15	V/F Pattern setting	001~007	001/004	*8
C16	V/F base output voltage (V)	198~265V / 380~530V	220/440	
C17	V/F Max. output frequency (Hz)	00.2~200	50.0/60.0	
C18	V/F Output voltage ratio at max frequency (%)	00.0~100	100	
C19	V/F Mid frequency (Hz)	00.1~200	25.0/60.0	



C	Function Description	Range/ Code	Factory Default	Remarks
C20	V/F Output voltage ratio at mid frequency (%)	00.0~100	50.0	
C21	V/F Min output frequency (Hz)	00.1~200	00.5/00.6	
C22	V/F Output voltage ratio at min frequency (%)	00.0~100	01.0	
C23	V/F Torque Boost Gain (%)	00.0~30.0	00.0	1
C24	V/F Slip Compensation Gain (%)	00.0 ~100	00.0	*1
C25	Motor no load current (A)	— — — — — — — — — —		Varies with motor rating *4
C26	Electronic thermal relay protection for motor (OL1)	000: Enable motor protection 001: Disable motor protection	00.0	
C27	Skip frequency #1 (Hz)	00.0~200	00.0	
C28	Skip frequency #2 (Hz)	00.0~200	00.0	
C29	Slip frequency range (±Hz)	00.0~30.0	00.0	
C30	PID operation mode	000: PID Function unavailable 001: PID control, deviation is derivate controlled 002: PID control, Feedback is derivate controlled 003: Same as 001 BUT reverse characteristics control 004: Same as 002 BUT reverse characteristics control	000	
C31	PID Error gain	0.00 - 10.0	1.00	*1
C32	Proportional gain P (%)	0.00 - 10.0	01.0	*1
C33	Integral time I (s)	0.00 - 100	10.0	*1
C34	Differential time D (s)	0.00 - 10.0	0.00	*1
C35	PID offset	000: Positive direction 001: Negative direction	000	*1
C36	PID offset adjust (%)	000 - 109	000	*1
C37	PID update time (s)	00.0 - 02.5	00.0	*1
C38	PID sleep set-point (Hz)	00.0~200	00.0	
C39	PID sleep delay time (s)	00.0~25.5	00.0	
C40	Frequency Up/Down control using MFIT	000: Up/Down command is available. Set frequency is held when inverter stops. 001: Up/Down command is available. Set frequency resets to 0Hz when inverter stops. 002: Up/Down command is available. Set frequency is held when inverter stops. Up/Down is available in stop.	000	
C41	Local/Remote frequency control select (run command by the Run/Stop key)	000: Up/Down key on keypad sets frequency 001: Potentiometer on the keypad set frequency	000	
C42	Terminal S5 function (option card)	000: Forward/stop command 001: Reverse/stop command 002: Preset speed command #1 003: Preset speed command #2 004: Preset speed command #3 005: Jog frequency command 006: Emergency stop (E.S.) 007: Base Block (b.b) 008: Use accel/decel time #2 009: Reset 010: Up command	007	



C	Function Description	Range/ Code	Factory Default	Remarks
C43	Terminal S6 function (option)	011: Down command 012: Control signal switch 013: Communication control signal switch 014: Acceleration/deceleration inhibition 015: Master/auxiliary speed source select 016: PID function disable 019: DC Brake signal *7	009	
C44	Multifunction input terminal S1~S6 signal scan time (ms x 8)	001~100	010	
C45	Confirming AIN signal scan time (ms x 8)	0~100	050	
C46	Multifunction output T+ T- (option)	000: Run 001: Frequency reached (Set frequency \pm F23) 002: Frequency is within the range set by (F22 \pm F23) 003: Frequency detection (>F22) 004: Frequency detection (<F22) 005: Fault conditions 006: Auto reset and restart 007: Momentary power loss 008: Emergency Stop (E.S.) 009: Base Block (b.b.) 010: Motor overload protection 011: Inverter overload protection 012: Retain 013: Power on 014: Communication error 015: Output current detection (>F24)	005	
C47	Remote keypad control selection	000: Disable (no signal loss detection) 001: Enable. On signal loss stop according to F09 002: Enable. Runs at the last set frequency. On signal loss Stop is according to F04 setting or stop key on keypad	000	Stop inverter then connect remote key pad for proper operation *4
C48	Copy module	000: Copy module disabled 001: Copy to module from inverter (read) 002: Copy to inverter from module (write) 003: Read/write check (compare the parameters)	000	*3
C49	Inverter communication address	001~254	001	*3 *4
C50	Baud rate (bps)	000: 4800 001: 9600 002: 9200 003: 38400	003	*3 *4
C51	Stop Bit	000: 1 stop bit 001: 2 stop bit	000	*3 *4
C52	Parity Bit	000: No parity 001: Even parity 002: Odd parity	000	*3 *4
C53	Data bits	000: 8 bits data 001: 7 bits data (Only for Modbus ASCII Mode)	000	*3 *4
C54	Communication time-out detection time (s)	00.0~25.5	00.0	*3 *4
C55	Communication time-out operation selection	000: Deceleration stop. (F02: deceleration time #1) 001: Coast to stop. 002: Deceleration stop. (C12: deceleration time #2). 003: Continue operating.	000	*3 *5



Note: *1: Can be modified in Run mode.

***2: Frequency resolution is 1Hz for settings above 100 Hz.**

***3: Cannot be modified during communication.**

***4: Do not change while making factory setting.**

F52 factory setting is 020(60HZ) and motor parameter value is 17.0.

F52 factory setting is 010(50HZ) and motor parameter value is 14.0.

***5: Available in Software version 1.2 or later**

***6: Changed in Software version 1.5 or later**

***7: Changed in Software version 1.6 or later**

***8: Changed in Software version 1.7 or later**

Chapter 3

Troubleshooting and maintenance



3.1 Error display and remedy

3.1.1. Errors which can not be recovered manually

Display	Error	Cause	Remedy
EPR	EEPROM problem.	EEPROM problem.	Replace EEPROM.
OV@	Over voltage during stop.	Voltage detection circuit malfunction.	Repair or replace unit.
LV@	Under voltage during stop.	<ol style="list-style-type: none"> 1. Power voltage too low. 2. Restraining resistor or fuse burnt out. 3. Detection circuit malfunctions. 	<ol style="list-style-type: none"> 1. Check if the power voltage is correct or not. 2. Replace the restraining resistor or the fuse. 3. Repair or replace unit.
OH@	The inverter is overheated during stop.	<ol style="list-style-type: none"> 1. Thermal detection circuit malfunction. 2. Ambient temperature too high or bad ventilation. 	<ol style="list-style-type: none"> 1. Repair or replace unit. 2. Improve ventilation conditions or relocate inverter.
CTR@	Current transducer detection error	Current transducer or circuit error.	Repair or replace unit

Note: “@” the Failure contact does not operate.

3.1.2. Errors which can be recovered both manually and automatically

Display	Error	Cause	Remedy
OCS	Over-current at start.	<ol style="list-style-type: none"> 1. Motor winding and frame short circuit. 2. Motor and ground short circuit. 3. Power module is damaged. 	<ol style="list-style-type: none"> 1. Check the motor. 2. Check the wiring. 3. Replace the power module.
OCD	Over-current at deceleration.	The preset deceleration time is too short.	Set a longer deceleration time.
OCA	Over-current at acceleration.	<ol style="list-style-type: none"> 1. Acceleration time is too short. 2. The capacity of the motor is higher than the capacity of the inverter. 3. Short circuit between motor winding and frame. 4. Short circuit between motor wiring and earth. 5. IGBT module is damaged. 	<ol style="list-style-type: none"> 1. Set a longer acceleration time. 2. Replace the inverter with the same or greater capacity as that of the motor. 3. Check the motor. 4. Check the wiring. 5. Replace the IGBT module.
OCC	Over-current during run.	<ol style="list-style-type: none"> 1. Transient load change. 2. Transient power change. 	Increase inverter capacity.
OVC	Over voltage during operation/deceleration.	<ol style="list-style-type: none"> 1. Deceleration time setting is too short or excessive load inertia. 2. Power voltage varies widely. 	<ol style="list-style-type: none"> 1. Set a longer deceleration time. 2. Add a braking resistor or braking unit. 3. Add a reactor at the input line side. 4. Increase inverter capacity.
OHC	High heat sink temperature during operation.	<ol style="list-style-type: none"> 1. Heavy load. 2. Ambient temperature too high or bad ventilation. 	<ol style="list-style-type: none"> 1. Check if there are any problems with the load. 2. Increase inverter capacity. 3. Improve ventilation conditions. 4. Inspect the setting value of parameter.
COT	Communication time-out detection	<ol style="list-style-type: none"> 1. C54 communication time-out detection time is too short. 2. Inverter communication is broke 3. Inverter can not receive the correct Modbus data within detection time. 	<ol style="list-style-type: none"> 1. Increase C54 communication time detection time. 2. Keep the inverter communication. 3. Check the received. Modbus data is correct from Master.

3.1.3 Errors which can be recovered manually but not automatically (no autorestart)

Display	Error	Cause	Remedy
OC	Over-current during stop.	1. OC Detection circuit malfunction. 2. Bad connection for CT signal cable.	Send the inverter back for repair.
OL1	Motor overload.	1. Heavy load. 2. Improper settings of F43.	1. Increase motor capacity. 2. Set F43 correctly according to motor nameplate.
OL2	Inverter overload.	Excessively heavy load.	Increase inverter capacity.
LVC	Under voltage during operation.	1. Power voltage too low. 2. Power voltage varies widely.	1. Improve power quality. 2. Set a longer acceleration time. 3. Add a reactor at the power input side. 4. Contact technical support.

3.1.4 Special conditions

Display	Error	Cause	Remedy
SP0	Zero speed stop	Set frequency is <0.1Hz	Increase set frequency.
SP1	Fail to start directly	1. If the inverter is set to external control mode (F04=001), and direct start is disabled (C09=001), the inverter cannot be started and will flash STP1 when the Run switch is ON when applying power (see descriptions of C09). 2. Direct start is possible when C09=000.SP1.	
SP2	Keypad emergency stop	1. If the inverter is set to external control mode (F04=001), the inverter will stop according to the setting of F09 when the stop key is pressed. STP2 flashes after stop. Turn the Run switch to OFF and then ON again to restart the inverter. 2. If the inverter is in communication mode and Stop key is enabled, the inverter will stop in the way set by F9 when Stop key is pressed during operation and then flashes STP2. The PC has to send a Stop command then a Run command to the inverter for it to be restarted. SP2.	
E.S.	External emergency stop	The inverter will decelerate to stop and flashes E.S. when there is an external emergency stop signal via the multi-function input terminals (see descriptions of F11~F14).	
b.b	External base block	The inverter stops immediately and then flashes b.b. when external base block is input through the multi-functional input terminal (see descriptions of F11~F14).	
PID	PID feedback signal loss	PID feedback signal circuit error detection.	
---	REMOTE KEYPAD cable broken	1. When REMOTE KEYPAD does not connect with inverter, this signal will be displayed on the Remote keypad. 2. When REMOTE KEYPAD connects with inverter, this signal will be displayed on the main keypad. 3. When both REMOTE KEYPAD and main KEYPAD display this signal means communication errors.	



3.1.5 Operation errors

Display	Error	Cause	Remedy
Er	Zero speed stop	<ol style="list-style-type: none"> 1. Attempt to Press ▲ or ▼ keys when F05> 000 or in speed operation. 2. Attempt to modify parameters, which can not be modified during Run (see parameter list). 	<ol style="list-style-type: none"> 1. ▼ or ▲ keys can be used to modify frequencies only when F05=000. 2. Modify parameters only in stop mode.
Er2	Parameter setting error.	<ol style="list-style-type: none"> 1. F07 is within ranges of C27±C29 or C28±C29. 2. F07<F08 or F07=F08. 	<ol style="list-style-type: none"> 1. Modify F32~F33 2. 3-00>3-01
Er5	Modification of parameter is not allowed during communication.	<ol style="list-style-type: none"> 1. Issue a control command during communication disabled. 2. Modify C49~C53 during communication. 3. Change C47 by remote keypad. 	<ol style="list-style-type: none"> 1. Issue the enabling command before while communicating. 2. Set up parameters before communicating. 3. Change C47 by inverter keypad.
Er6	Communication error.	<ol style="list-style-type: none"> 1. Incorrect wiring. 2. Incorrect setting of communication parameters. 3. Check-sum error. 4. Incorrect communication verification. 	<ol style="list-style-type: none"> 1. Check the hardware and wiring. 2. Check C49~C53.
EP1	Incorrect parameter setting.	<ol style="list-style-type: none"> 1. Attempt to modify F00. 2. Voltage and current detection circuits are malfunctioning. 	Reset inverter or contact technical support.
Er7	Parameter set error, Copy Unit failure.	<ol style="list-style-type: none"> 1. Set C48=1.2, can not connect with Copy Unit. 2. Copy Unit failure. 3. The voltage and drive rating on Copy Unit & the inverter are different. 	<ol style="list-style-type: none"> 1. Modify C48. 2. Change Copy Unit. 3. Copy from keypad to inverter with only matched HP ratings.
EP2	Parameters do not match.	Copy the parameter to inverter to verify the parameter not matched.	<ol style="list-style-type: none"> 1. Change Copy Unit. 2. The voltage and HP rating of Copy Unit is different than the inverter.



3.2 General functional troubleshooting

Status	Checking point	Corretive Action
Motor does not run	Is power applied to L1, L2, and L3 (N) terminals (is the charging indicator lit)?	<ul style="list-style-type: none"> • Is the power applied? • Turn the power OFF and then ON again. • Make sure the input line voltage is correct. • Make sure all terminal screws are secured firmly.
	Are there voltage outputs on T1, T2, and T3 terminals?	Turn the power OFF and then ON again.
	Is the motor mechanically overloaded?	• Reduce the load to improve performance.
	Are there any problems with the inverter?	• See error descriptions to check wiring and correct if necessary
	Has the forward or reverse run commands been issued?	
	Is there an analog input signal?	<ul style="list-style-type: none"> • Is analog frequency input signal wiring correct? • Is frequency input voltage correct?
	Is operation mode setting correct?	• Configure operations through the digital panel.
Motor rotates in the wrong direction	Are wiring for output terminals T1, T2 and T3 correct?	• Wiring must match U, V, and W terminals of the motor.
	Are wiring for forward and reverse signals correct?	• Check wiring and correct if necessary.
Motor rotates in the wrong direction the motor speed can not vary.	Are wiring for output terminals T1, T2, and T3 correct?	• Check wiring and correct if necessary.
	Is the setting of frequency command source correct?	• Check the operation mode setting on the keypad
	Is the load too large?	• Reduce the applied load
Motor running at too high or too low speeds.	Is the setting of operation mode correct?	• Confirm the motor's specifications
	Is the load too large?	• Confirm the gear ratio
	Are specifications of the motor (poles, voltage) correct?	• Confirm the highest output frequency
Motor speed is incorrect or erratic.	Is the gear ratio correct?	• Reduce the load
	Is the setting of the highest output frequency correct?	<ul style="list-style-type: none"> • Minimize the variation of the load • Increase capacities of the inverter and the motor
	Is the load too large?	<ul style="list-style-type: none"> • Add an AC reactor at the power input side if using single-phase power • Check wiring if using three-phase power

Appendix 1:

RVEF parameter setting list



Customer					Inverter Model	
Using Site					Contact Phone	
Address:						
Parameter code	Setting	Parameter code	Setting	Parameter code	Setting	
F00		F38		C22		
F01		F39		C23		
F02		F40		C24		
F03		F41		C25		
F04		F42		C26		
F05		F43		C27		
F06		F44		C28		
F07		F45		C29		
F08		F46		C30		
F09		F47		C31		
F10		F48		C32		
F11		F49		C33		
F12		F50		C34		
F13		F51		C35		
F14		F52		C36		
F15		F53		C37		
F16		F54		C38		
F17		C01		C39		
F18		C02		C40		
F19		C03		C41		
F20		C04		C42		
F21		C05		C43		
F22		C06		C44		
F23		C07		C45		
F24		C08		C46		
F25		C09		C47		
F26		C10		C48		
F27		C11		C49		
F28		C12		C50		
F29		C13		C51		
F30		C14		C52		
F31		C15		C53		
F32		C16		C54		
F33		C17		C54		
F34		C18		C55		
F35		C19				
F36		C20				
F37		C21				

Appendix 2: CE certificate



CARLO GAVAZZI
Automation Components

CARLO GAVAZZI LOGISTICS SpA
Administrative and directive headquarter: Via Milano 13, I – 20020 Lainate (MI)
Tel.: ++39 02 93176.1, Fax ++39 02 93176.403
Internet: <http://www.carlogavazzi.com>



CE Declaration of Conformity

We, Manufacturer, **CARLO GAVAZZI LOGISTICS S.p.A.**, located at Via Milano,13
20020 Lainate (ITALY), declare under our own responsibility that the products here listed

RVCF series of Motor Controllers Variable Frequency AC Drives

are in conformity with

The Low-Voltage Directive 73/23/EEC, as amended by 93/68/EEC,

The EMC Directive 89 / 336 / EEC,

referring to the below listed standards

EN 61800-5-1: Adjustable speed electrical power drive systems. Safety requirements. Electrical, thermal and energy

EN 61800-3: Adjustable speed electrical power drive systems. EMC requirements and specific test methods.

EN 61000-6-2: Electromagnetic compatibility (EMC) - Part 6-2: Generic standards - Immunity for industrial environments

EN 61000-6-4: Electromagnetic compatibility (EMC). Generic standards. Emission standard for industrial environments

EN 61000-3-2: Electromagnetic compatibility (EMC). Limits. Limits for harmonic current emissions (equipment input current up to and including 16 A per phase)

EN 61000-3-3 Electromagnetic Compatibility (EMC). Limitation of voltage changes, voltage fluctuations and flicker in public low-voltage supply systems, for equipment with rated current less than or equal to 16 A per phase and not subject to conditional connection

Compliance with these directives will require the application of a correct installation, maintenance and use conforming to intended purpose of the product, following the supplier's instructions and accepted rules of the art. The product must be installed and connected by skilled personnel who are authorised to be responsible for the safety of the equipment, at all times, even whilst carrying out their normal duties, and are therefore aware of, and can report, possible safety hazards.



CE marking

Design and manufacturing follows the provisions of the Low Voltage Directive of the European Communities as of February 19. 1973 as changed by 93 / 68 / EEC and the EMC Directive 89 / 336 / EEC as changed by 92 / 31 / EEC and 93 / 68 / EEC.

Manufacturer

Place / Date : Lainate , November, 19th / 2008



Signature : 
Name : Graziano Padovan

Appendix 3

UL Listing and CE certification Information



III.1 Approvals Table

	CE approval	Europe	See attached certificate
	UL / cULs approval	USA & Canada	File number E319186
	RoHS	-	-

III.2 Common UL information (for VariFlex Size 1 and 2)

Conformity

The drive conforms to UL listing requirements only when the following are observed:

- Class 1 60/75°C (140/167°F) copper wire only is used in the installation
- The ambient temperature does not exceed 40°C (104°F) when the drive is operating
- The terminal tightening torques specified in section 4.1 Power terminal connections are used

AC supply specification

The drive is suitable for use in a circuit capable of delivering not more than 100,000 RMS symmetrical Amperes at 264Vac RMS maximum (200V drives) or 528Vac RMS maximum (400V drives).

Motor overload protection

The drive provides motor overload protection. The overload protection level is 150% of full-load current. RVEF Advanced User Guide for further information.

Overspeed protection

The drive provides overspeed protection. However, it does not provide the level of protection afforded by an independent high integrity overspeed protection device.

Power dependant UL information

The drive conforms to UL listing requirements only when the following is observed:

- UL listed class CC fast acting fuses e.g. Bussman Limitron KTK series, Gould Amp-Trap ATM series or equivalent are used in the AC supply.

OUR SALES NETWORK IN EUROPE

AUSTRIA - Carlo Gavazzi GmbH
Ketzergasse 374, A-1230 Wien
Tel: +43 1 888 4112
Fax: +43 1 889 10 53
office@carlogavazzi.at

BELGIUM - Carlo Gavazzi NV/SA
Schaarbeeklei 213/3, B-1800 Vilvoorde
Tel: +32 2 257 4120
Fax: +32 2 257 41 25
sales@carlogavazzi.be

DENMARK - Carlo Gavazzi Handel A/S
Over Hadstenevej 40, DK-8370 Hadsten
Tel: +45 89 60 6100
Fax: +45 86 98 15 30
handel@gavazzi.dk

FINLAND - Carlo Gavazzi OY AB
Petaksentie 2-4, FI-00661 Helsinki
Tel: +358 9 756 2000
Fax: +358 9 756 20010
myynti@carlogavazzi.fi

FRANCE - Carlo Gavazzi Sarl
Zac de Paris Nord II, 69, rue de la Belle
Etoile, F-95956 Roissy CDG Cedex
Tel: +33 1 49 38 98 60
Fax: +33 1 48 63 27 43
french.team@carlogavazzi.fr

GERMANY - Carlo Gavazzi GmbH
Pfnorstr. 10-14
D-64293 Darmstadt
Tel: +49 6151 81000
Fax: +49 6151 81 00 40
info@gavazzi.de

GREAT BRITAIN - Carlo Gavazzi UK Ltd
7 Springlakes Industrial Estate,
Deadbrook Lane, Hants GU12 4UH,
GB-Aldershot
Tel: +44 1 252 339600
Fax: +44 1 252 326 799
sales@carlogavazzi.co.uk

ITALY - Carlo Gavazzi SpA
Via Milano 13, I-20020 Lainate
Tel: +39 02 931 761
Fax: +39 02 931 763 01
info@gavazziacbu.it

NETHERLANDS - Carlo Gavazzi BV
Wijkermeerweg 23,
NL-1948 NT Beverwijk
Tel: +31 251 22 9345
Fax: +31 251 22 60 55
info@carlogavazzi.nl

NORWAY - Carlo Gavazzi AS
Melkeveien 13, N-3919 Porsgrunn
Tel: +47 35 93 0800
Fax: +47 35 93 08 01
gavazzi@carlogavazzi.no

PORTUGAL - Carlo Gavazzi Lda
Rua dos Jerónimos 38-B,
P-1400-212 Lisboa
Tel: +351 21 361 7060
Fax: +351 21 362 13 73
carlogavazzi@carlogavazzi.pt

SPAIN - Carlo Gavazzi SA
Avda. Iparraguirre, 80-82,
E-48940 Leioa (Bizkaia)
Tel: +34 94 480 4037
Fax: +34 94 480 10 61
gavazzi@gavazzi.es

SWEDEN - Carlo Gavazzi AB
V:a Kyrkogatan 1,
S-652 24 Karlstad
Tel: +46 54 85 1125
Fax: +46 54 85 11 77
info@carlogavazzi.se

SWITZERLAND - Carlo Gavazzi AG
Verkauf Schweiz/Vente Suisse
Sumpfstrasse 32,
CH-632 Steinhausen
Tel: +41 41 747 4535
Fax: +41 41 740 45 40
info@carlogavazzi.ch

OUR SALES NETWORK IN NORTH AMERICA

USA - Carlo Gavazzi Inc.
750 Hastings Lane,
USA-Buffalo Grove, IL 60089,
Tel: +1 847 465 6100
Fax: +1 847 465 7373
sales@carlogavazzi.com

CANADA - Carlo Gavazzi Inc.
2660 Meadowvale Boulevard,
CDN-Mississauga Ontario L5N 6M6,
Tel: +1 905 542 0979
Fax: +1 905 542 22 48
gavazzi@carlogavazzi.com

MEXICO - Carlo Gavazzi Mexico S.A. de
C.V.
Calle La Montaña no. 28, Fracc. Los Pastores
Naucalpan de Juárez, EDOMEX CP 53340
Tel & Fax: +52.55.5373.7042
mexicosales@carlogavazzi.com

OUR SALES NETWORK IN ASIA AND PACIFIC

SINGAPORE - Carlo Gavazzi Automation
Singapore Pte. Ltd.
61 Tai Seng Avenue #05-06
UE Print Media Hub
Singapore 534167
Tel: +65 67 466 990
Fax: +65 67 461 980

MALAYSIA - Carlo Gavazzi Automation
(M) SDN. BHD.
D12-06-G, Block D12,
Pusat Perdagangan Dana 1,
Jalan PJU 1A/46, 47301 Petaling Jaya,
Selangor, Malaysia.
Tel: +60 3 7842 7299
Fax: +60 3 7842 7399

CHINA - Carlo Gavazzi Automation
(China) Co. Ltd.
Rm. 2308 - 2310, 23/F.,
News Building, Block 1,
1002 Shennan Zhong Road,
Shenzhen, China
Tel: +86 755 83699500
Fax: +86 755 83699300

HONG KONG - Carlo Gavazzi
Automation Hong Kong Ltd.
Unit 3 12/F Crown Industrial Bldg.,
106 How Ming St., Kowloon,
Hong Kong
Tel: +852 23041228
Fax: +852 23443689

OUR PRODUCTION SITES

Carlo Gavazzi Industri A/S
Hadsten - **DENMARK**

Carlo Gavazzi Ltd
Zejtun - **MALTA**

Carlo Gavazzi Controls SpA
Belluno - **ITALY**

Uab Carlo Gavazzi Industri Kaunas
Kaunas - **LITHUANIA**

Carlo Gavazzi Automation
(Kunshan) Co., Ltd.
Kunshan - **CHINA**

HEADQUARTERS

Carlo Gavazzi Automation SpA
Via Milano, 13 - I-20020
Lainate (MI) - **ITALY**
Tel: +39 02 931 761
info@gavazzi-automation.com

Sense Switch Control Fieldbus EcoEnergy
equipment

CARLO GAVAZZI
Automation Components

Further information on
www.gavazziautomation.com - www.carlogavazzi.com

CARLO GAVAZZI