



**Motor Controllers AC Variable Frequency Drives  
Type VariFlex<sup>3</sup> RVLf**

**Switches**



<b>RVLF Series</b>	<b>100V</b>	0.4-0.75kW (0.5-1HP)
	<b>200V</b>	0.4-2.2kW (0.5-3HP)
	<b>400V</b>	0.75-2.2kW (1-3HP)





# Index

<b>0. Preface</b>	<b>3</b>
<b>1. Safety Precautions</b>	<b>4</b>
1.1. Before power UP	4
1.2. During power UP	5
1.3. Before operation	5
1.4. During operation	6
1.5. Inverter disposal	6
<b>2. Part Number Definition</b>	<b>7</b>
2.1. Model part number	7
2.2. Standard product specification	7
<b>3. Environment &amp; Installation</b>	<b>8</b>
3.1. Environment	8
3.2. Installation	9
3.2.1 Installation methods	9
3.2.2 Installation space	12
3.2.3 Derating curve	13
3.2.4 Capacitor reforming guide after long storage	14
3.2.5 Installation instruction with ferrite ring core	14
3.3. Wiring guidelines	14
3.3.1 Main consideration	14
3.3.2 Control cable selection and wiring	16
3.3.3 Wiring and EMC guidelines	17
3.3.4 Failure liability	18
3.3.5 Considerations for peripheral equipment	19
3.3.6 Ground connection	20
3.3.7 Inverter exterior	20
3.4. Specifications	21
3.4.1 Inverter exterior	21
3.4.2 General specifications	23
3.5. Standard wiring	25
3.5.1 Single phase (NPN input)	25
3.5.2 Single phase (PNP input)	26
3.5.3 Three phase (NPN input)	27
3.5.4 Three phase (PNP input)	28
3.5.5 Three phase (PNP - NPN)	29
3.6. Terminal description	30
3.6.1 Terminal description	30
3.6.2 Control circuit terminal description	31
3.7. Outline dimension	33
3.8. Filter disconnection	36



<b>4. Software Index</b>	<b>37</b>
4.1. Keypad description	37
4.1.1 Operator panel functions	37
4.1.2 Digital display description	38
4.1.3 Digital display setup	40
4.1.4 Example of keypad operation	42
4.1.5 Operation control	44
4.2. Programmable parameter groups	45
<b>Annex 1: Consignes de sécurité</b>	<b>59</b>





## 0 Preface

To extend the performance of the product and ensure personnel safety, please read this manual thoroughly before using the inverter. Should there be any problem in using the product that cannot be solved with the information provided in the manual, contact our technical or sales representative who will be willing to help you.

### Precautions

The inverter is an electrical product. For your safety, there are symbols such as “Danger”, “Caution” in this manual as a reminder to pay attention to safety instructions on handling, installing, operating, and checking the inverter. Be sure to follow the instructions for highest safety.

**Danger** Indicates a potential hazard that could cause death or serious personal injury if misused.

**Caution** Indicates that the inverter or the mechanical system might be damaged if misused.

### Danger

- Risk of electric shock. The DC link capacitors remain charged for five minutes after power has been removed. It is not permissible to open the equipment until 5 minutes after the power has been removed.
- Do not make any connections when the inverter is powered on. Do not check parts and signals on circuit boards during the inverter operation.
- Do not disassemble the inverter or modify any internal wires, circuits, or parts.
- Ensure that the inverter ground terminal is connected correctly.

### Caution

- Do not perform a voltage test on parts inside the inverter. High voltage can destroy the semiconductor components.
- Do not connect T1, T2, and T3 terminals of the inverter to any AC input power supply.
- CMOS ICs on the inverter’s main board are susceptible to static electricity. Do not touch the main circuit board.



# 1. Safety Precautions

## 1.1. Before Power Up

---

**Danger** Make sure the main circuit connections are correct. Single phase L1 (L), L3 (N), and Three phase L1(L), L2, L3 (N); 400V: L1, L2, L3 are power-input terminals and must not be mistaken for T1, T2 and T3. Otherwise, inverter damage can result.

### Caution

- The line voltage applied must comply with the inverter's specified input voltage. (See the nameplate).
- To avoid the front cover from disengaging, or other damage do not carry the inverter by its covers. Support the drive by the heat sink when transporting. Improper handling can damage the inverter or injure personnel and should be avoided.
- To avoid the risk of fire, do not install the inverter on a flammable object. Install on nonflammable objects such as metal.
- If several inverters are placed in the same control panel, provide heat removal means to maintain the temperature below 50°C to avoid overheat or fire.
- When disconnecting the remote keypad, turn the power off first to avoid any damage to the keypad or the inverter.

### Warning

- This product is sold subject to EN 61800-3 and EN 61800-5-1. In a domestic environment this product may cause radio interference in which case the user may be required to apply corrective measures.
- Motor over temperature protection is not provided.

### Caution

- Work on the device/system by unqualified personnel or failure to comply with warnings can result in severe personal injury or serious damage to material. Only suitably qualified personnel trained in the setup, installation, commissioning and operation of the product should carry out work on the device/system.
- Only permanently-wired input power connections are allowed.



## 1.2. During Power Up

---

- Danger** When the momentary power loss is longer than 2 seconds, the inverter will not have sufficient stored power for its control circuit. Therefore, when the power is re-applied, the run operation of the inverter will be based on the setup of following parameters:
- Run parameters. 00-02 or 00-03.
  - Direct run on power up. Parameter. 07-04 and the status of external run switch,

**Note:** The start operation will be regardless of the settings for parameters 07-00/07-01/07-02.

### **Danger. Direct run on power up.**

If direct run on power up is enabled and inverter is set to external run with the run FWD/REV switch closed then the inverter will restart

### **Danger**

- Prior to use, ensure that all risks and safety implications are considered.
- When the momentary power loss ride through is selected and the power loss is short, the inverter will have sufficient stored power for its control circuits to function, therefore, when the power is resumed the inverter will automatically restart depending on the setup of parameters 07-00 & 07-01.

## 1.3. Before Operation

---

**Caution** Make sure the model and inverter capacity are the same as that set in parameter 13-00.

**Note:** On power up the supply voltage set in parameter 01-01 will flash on display for 2 seconds.



## 1.4. During Operation

---

**Danger** Do not connect or disconnect the motor during operation. Otherwise, It may cause the inverter to trip or damage the unit.

**Danger**

- To avoid electric shock, do not take the front cover off while power is on.
- The motor will restart automatically after stop when auto-restart function is enabled. In this case, care must be taken while working around the drive and associated equipment.
- The operation of the stop switch is different than that of the emergency stop switch. The stop switch has to be activated to be effective. Emergency stop has to be de-activated to become effective.

**Caution**

- Do not touch heat radiating components such as heat sinks and brake resistors.
- The inverter can drive the motor from low speed to high speed. Verify the allowable speed ranges of the motor and the associated machinery.
- Note the settings related to the braking unit.
- Risk of electric shock. The DC link capacitors remain charged for five minutes after power has been removed. It is not permissible to open the equipment until 5 minutes after the power has been removed.

**Caution**

- The Inverter should be used in environments with temperature range from (14 to +104°F) or (-10 to +40°C) and relative humidity of 95%.

**Danger**

- Make sure that the power is switched off before disassembling or checking any components.

## 1.5. Inverter Disposal

---

**Caution**

Please dispose of this unit with care as an industrial waste and according to your required local regulations.

- The capacitors of inverter main circuit and printed circuit board are considered as hazardous waste and must not be burnt.
- The plastic enclosure and parts of the inverter such as the cover board will release harmful gases if burnt.



WEEE designation

Do not dispose of the product together with the household waste but according to the disposal regulations for electronic waste locally applicable at the product installation site.



## 2. Part Number Definition

### 2.1. Model Part Number

#### Ordering Key

**RVLFA 1 20 075 F A**

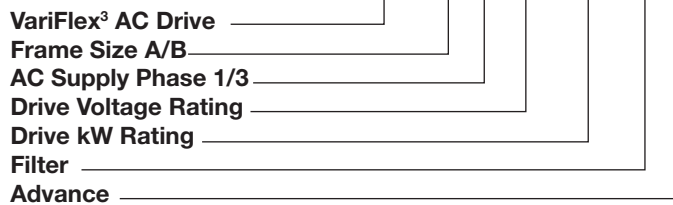

Frame Size	AC Supply Phase	Drive Voltage Rating	Drive kW Rating
A: Size 1 B: Size 2	1: 1-Phase 3: 3-Phase	10: 100-120VAC 20: 200-240VAC 40: 380-480VAC	040: 0.40kW, 0.50HP
			075: 0.75kW, 1.0HP
			150: 1.5kW, 2.0HP
			220: 2.2kW, 3.0HP
			370: 3.7KW, 5.0HP
			550: 5.5KW, 8.0HP
			750: 7.5KW, 10HP
			1100: 11KW, 15HP

Filter	Advance
<b>Nil:</b> No inbuilt Filter <b>F:</b> Inbuilt filter	<b>A:</b> Advance. Sensorless vector control

### 2.2. Standard Product Specification

Model	Supply Voltage (Vac)	Frequency (Hz)	(HP)	(KW)	Filter	SLV
RVLFA110040A	1Ph, 100-120V +10%/-15%	50/60Hz	0.5	0.4		•
RVLFA110075A			1	0.75		•
RVLFA120040FA	1Ph, 200-240V +10%/-15%		0.5	0.4	•	•
RVLFA120075FA			1	0.75	•	•
RVLFB120150FA			2	1.5	•	•
RVLFB120220FA			3	2.2	•	•
RVLFA320040A	3Ph, 200-240V +10%/-15%		0.5	0.4		•
RVLFA320075A			1	0.75		•
RVLFB320150A			2	1.5		•
RVLFB320220A			3	2.2		•
RVLFB340075FA	3Ph, 380-480V +10%/-15%		1	0.75	•	•
RVLFB340150FA			2	1.5	•	•
RVLFB340220FA		3	2.2	•	•	
RVLFC340370FA		5	3.7	•	•	
RVLFC340550FA		8	5.5	•	•	
RVLFD340750FA		10	7.5	•	•	
RVLFD3401100FA		15	11	•	•	

Short circuit capacity is below 5000A/120V or 5000A/240V or 5000A/480V, for 100~120V models is 120V; 200-240V models is 240V, 380-480V for 480V.





# 3. Environment & Installation

## 3.1. Environment

Installation environment has a direct affect on the correct operation and the life expectancy of the inverter, Install the inverter in an environment complying with the following conditions:

Protection	
Protection class	IP20, NEMA/UL Open Type
Suitable environment	
Operating temperature	-10~+40°C (-10~+50°C with fan) If several inverters are installed in the same control panel, ensure adequate spacing and provide the necessary cooling and ventilation for successful operation.
Storage temperature	-20~+60°C
Relative humidity	Max 95% (without condensation) Notice prevention of inverter freezing up.
Shock and Vibration	0.075mm Amplitude for 10Hz to 57Hz 1G for 57Hz to 150Hz

### Installation site

Install in an environment that will not have an adverse effect on the operation of the unit and ensure that there is no exposure to areas such as that listed below:

- Direct sunlight, rain or moisture
- Oil mist and salt
- Dust, lint fibbers, small metal filings and corrosive liquid and gas
- Electromagnetic interference from sources such as welding equipment
- Radioactive and flammable materials
- Excessive vibration from machines such as stamping, punching machines
- Add a vibration-proof pads if necessary

Product Overview

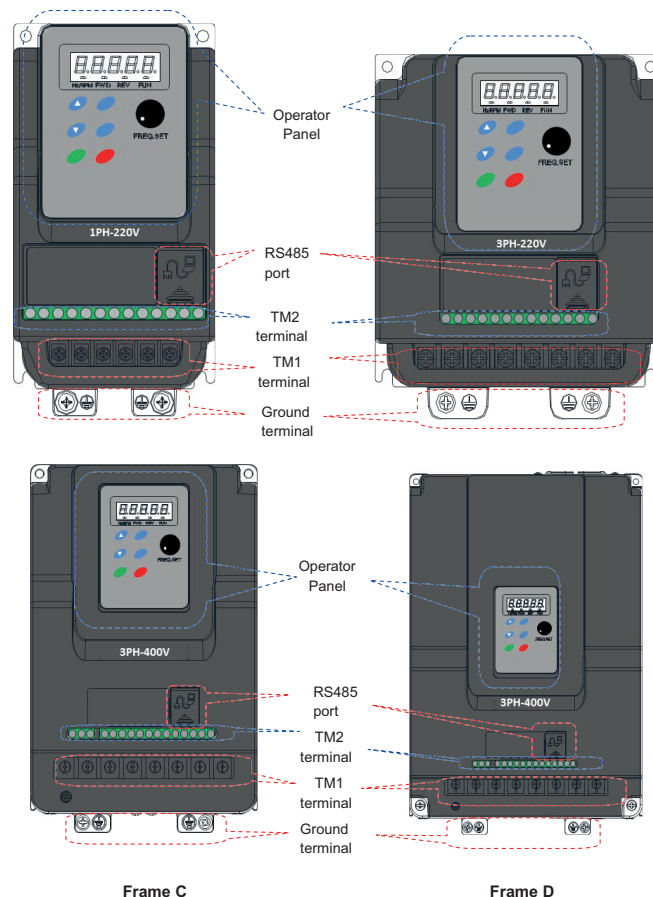

## 3.2. Installation

### 3.2.1. Installation methods

#### Frame1. Mounting on a flat surface.

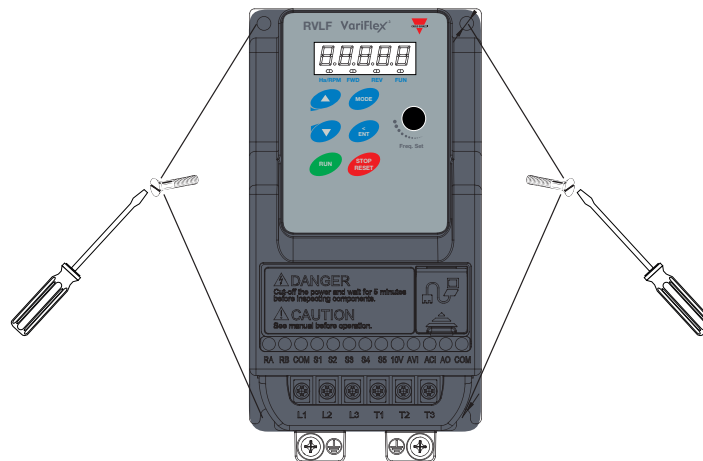

#### DIN rail type installation:

DIN rail kit includes a plastic and a metal adaptor plates.

#### Assembly Steps:

- 1) Attach the metal adaptor plate to the inverter base with the screws provided.
- 2) Attach the plastic din rail adaptor to the metal adaptor plate.
- 3) Push the plastic adaptor forward to lock into position.

#### Disassembly Steps:

- 1) Unlock by pushing the snap hooks
- 2) Retract and remove the plastic DIN rail adaptor.
- 3) Unscrew the metal plate & remove

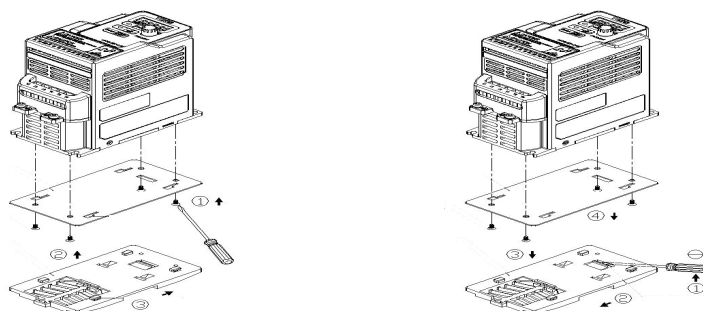

#### Note:

RVLV-DIN-01 (Size 1 din rail kit part number), including the following parts

1. Metal plate adaptor
2. Plastic adaptor
3. Chamfer head screw: M3×6



**Frame 2. Mounting on a flat surface.**

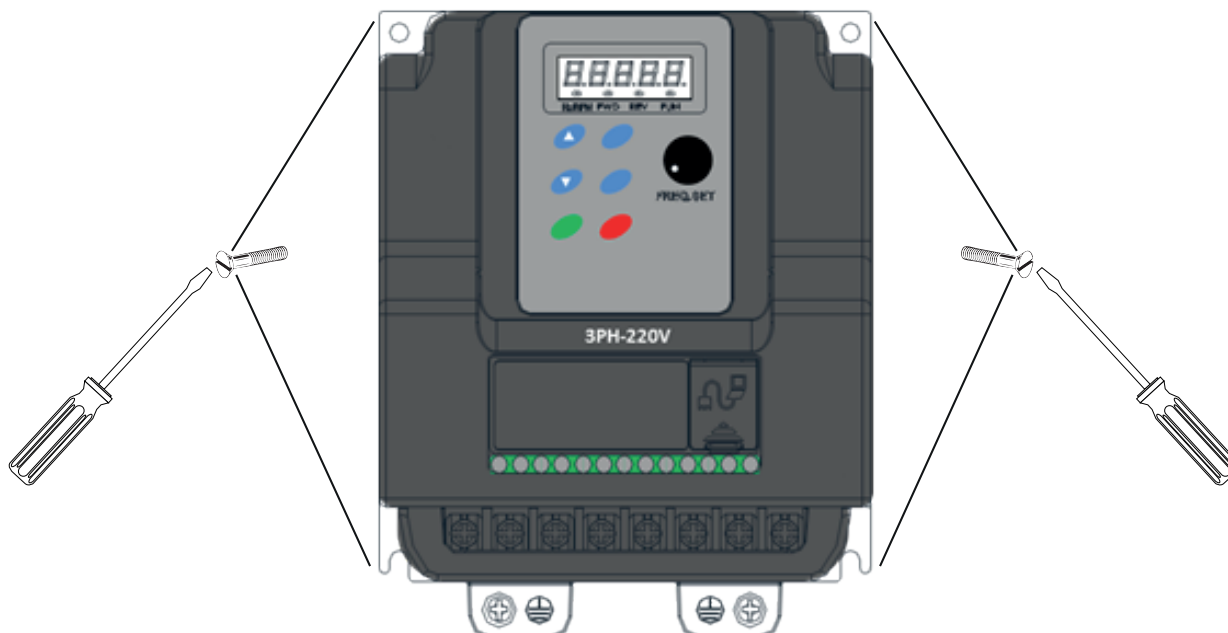

**DIN rail type installation:**

DIN rail kit includes a plastic adaptor plate as an attachment for the inverter base. Refer to diagram below:

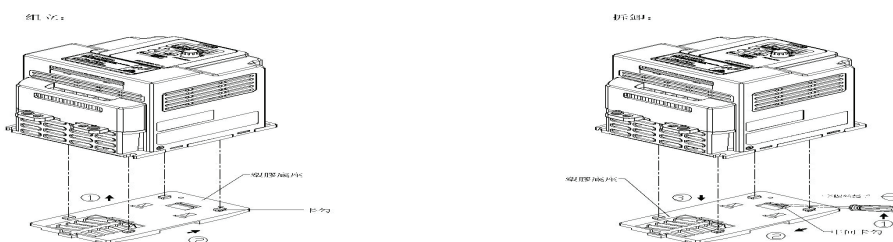

DIN rail mounting & dismounting as shown in the diagram below: Use a 35mm DIN rail.

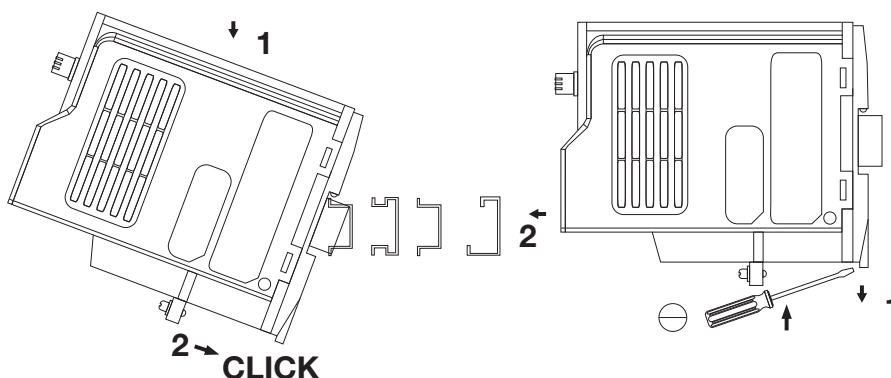

Plastic adaptor plate.  
RVLF-DIN02 (Size 2 DIN rail kit part number)

**Frame 3. Mounting on a flat surface.**

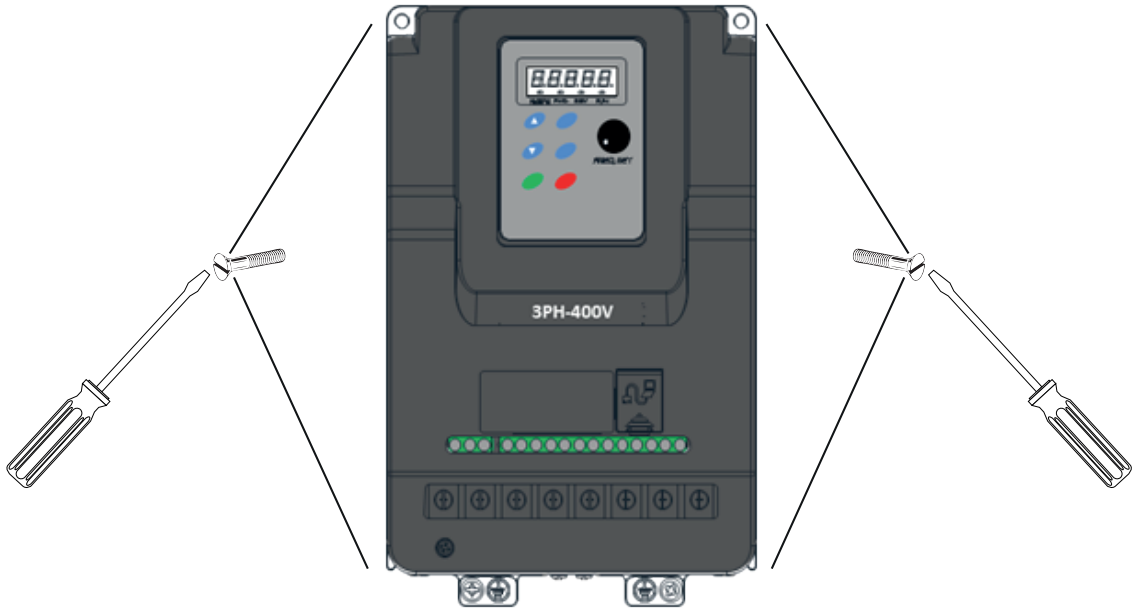

**Frame 3. Mounting on a flat surface.**

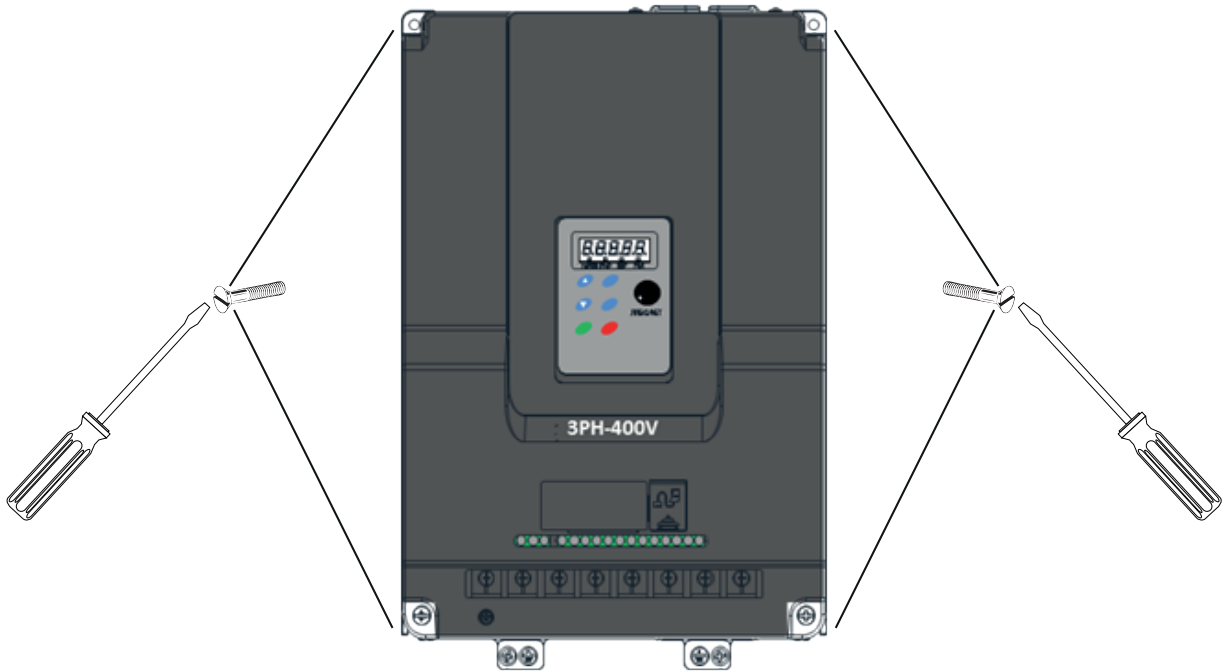



### 3.2.2. Installation Space

Provide sufficient air circulation space for cooling as shown in examples below. Install the Inverter on surfaces that provide good heat dissipation.

#### Single unit Installation

Install the inverter vertically to obtain effective cooling

#### Frames 1 & 2.

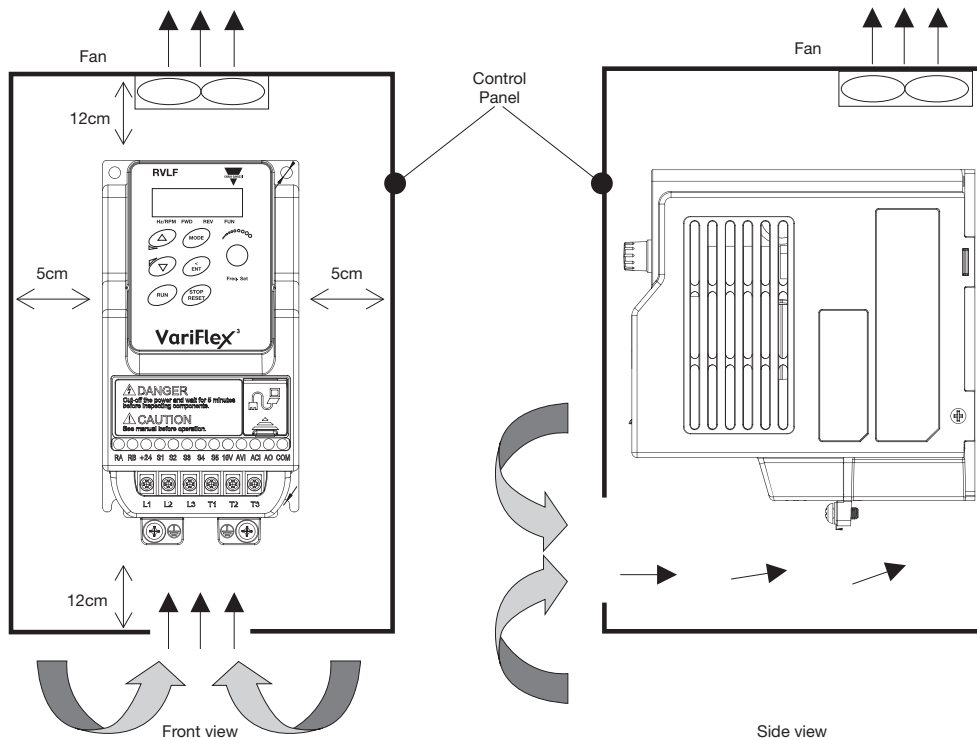

#### Side by side Installation

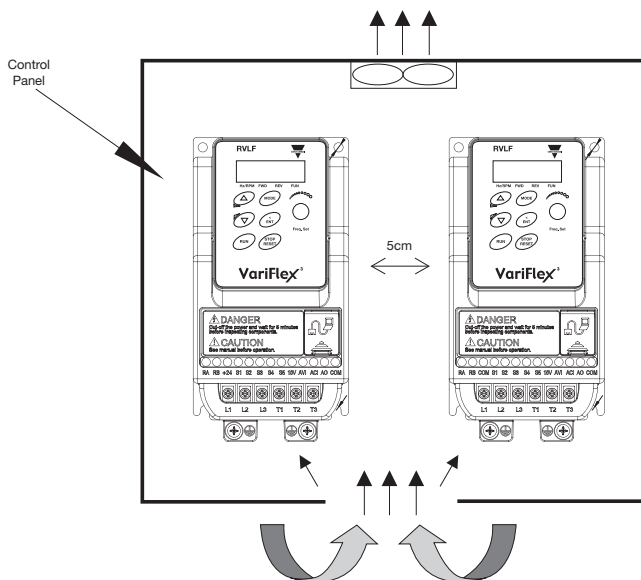

Provide the necessary physical space and cooling based on the ambient temperature and the heat loss in the panel.





### 3.2.3. Derating Curve

Curves below show the applicable output current de-rate due to setting of carrier frequency and the ambient operating temperatures of 40 and 50°C.

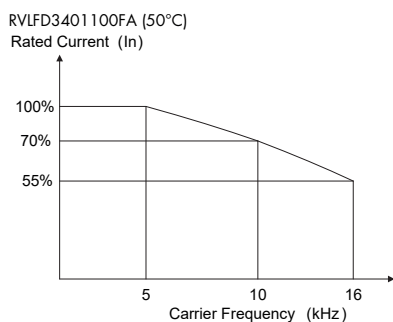
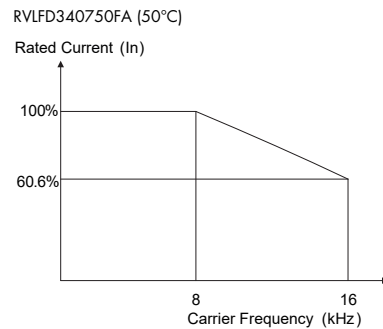
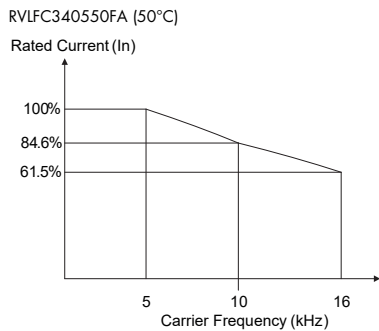
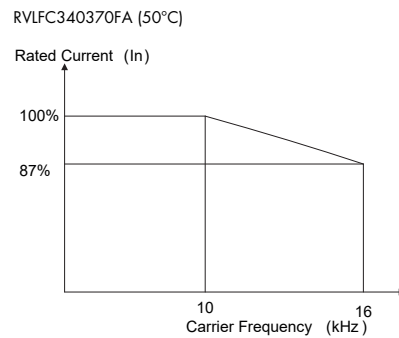
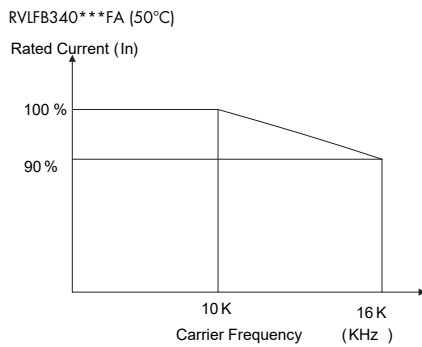
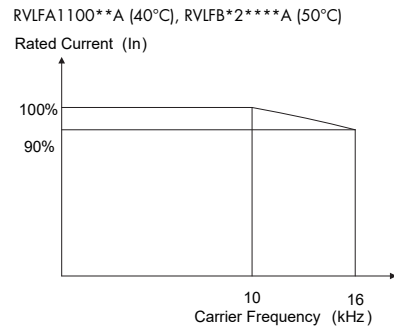
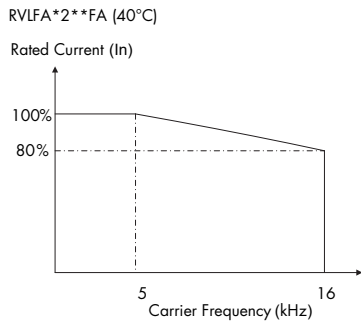



### 3.2.4 Capacitor reforming guide after long storage

For correct performance of this product after long storage before use it is important that Inverter Capacitors are reformed according to the guide below:

Storage time	Procedure to re-apply voltage
≤ 1 year	Apply rated voltage(Note1) of inverter in the normal way
Between 1-2 years	Apply rated voltage of inverter to the product for one hour before using the inverter
≥ 2 years	Use a variable AC power supply to <ol style="list-style-type: none"> <li>1.Connecting 25% rated voltage of inverter for 30 minutes.</li> <li>2.Connecting 50% rated voltage of inverter for 30 minutes.</li> <li>3.Connecting 75% rated voltage of inverter for 30 minutes.</li> <li>4.Connecting 100% rated voltage of inverter for 210 minutes. Once the procedures completed, inverter just can be used normally.</li> </ol>

Note 1: Rated voltage: please refer the rated voltage according to model label of inverter.

### 3.2.5 Installation instruction with ferrite ring core

Ferrite cores should be installed with the following units to reduce the leakage current in the built-in filter. These will improve the functionality of the drives with 30mA RCDs.

Supply	Voltage (VAC)	Rating (kW)	Drive	Ferrite core
1-Ph	200	0.40	RVLFA120040FA	1
		0.75	RVLFA120075FA	1
		1.50	RVLFB120150FA	2
		2.20	RVLFB120220FA	2

Installation diagrams:

#### A. RVLFA120040FA / RVLFA120075FA

- Installation position: The wiring between supply and drive (main power input).
- Installation procedure: The power cord should be wound through the ferrite ring core in the same direction for 3 rounds; and then connected to the main power input L1(L) L3(N).

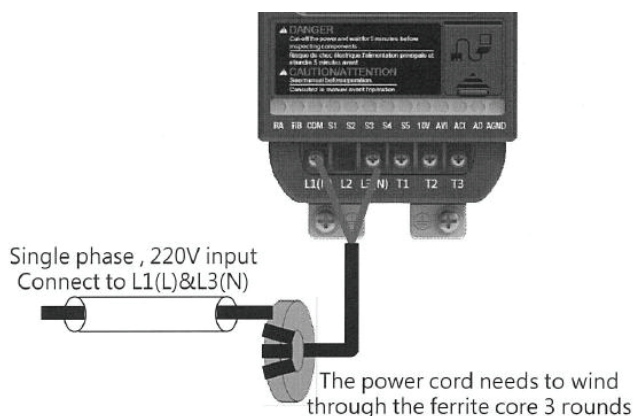

### B. RVLFB120150FA / RVLFB120220FA

- Installation position: The wiring between supply and drive (main power input).  
The wiring between earth and drive (ground terminal).
- Installation procedure: The power cord should be wound through the ferrite ring core in the same direction for 2 rounds; and then connected to the main power input L1(L) L3(N).  
The earth conductor should be wound through the ferrite ring core in the same direction for 3 rounds; and then connected to the ground terminal.

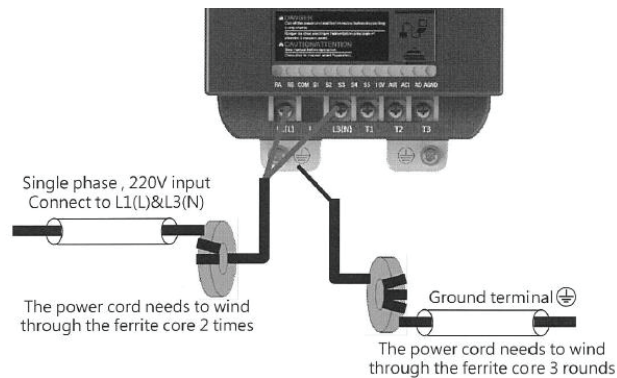



### 3.3. Wiring Guidelines

#### 3.3.1. Main Considerations

1. Tightening Torque for Screw terminals : Refer to the tables 3-1, when using a screwdriver or any other suitable tools to make connections.
2. Power terminals:  
 Single phase : L1 (L), L3 (N)  
 Three-phase 200V models: L1 (L), L2, L3 (N)  
 400V models: L1, L2, L3
3. For all cabling use copper wires and the cable size shall be according to the table below rated at 105 degrees Celsius.
4. Power & Control cable Minimum rated voltage  
 240V AC system, 300V AC.  
 480V AC system, 600V AC.
5. Control cables should be separated from the power cables. Do not place them in the same cable tray or cable trunking to prevent against electrical interference.

Frame size	TM1					TM1/TM2				
	Cable Size		Tightening torque			Cable Size		Tightening torque		
	AWG	mm <sup>2</sup>	kgf.cm	lbf.in	Nm	AWG	mm <sup>2</sup>	kgf.cm	lbf.in	Nm
Frame A	22~10	0.34~6	14	12.15	1.37	24~12	0.5~2.5	4.08	3.54	0.4
Frame B			12.24	10.62	1.2					
Frame C	18~8	0.82~8.4	18	15.58	1.76	24~12	0.5~2.5	5.1	4.43	0.5
Frame D	14~6	2~13.3	24.48	21.24	2.4					

Supply power cable must be connected to TM1 terminal block, terminals L1 (L) and L3 (N) for single phase 200V supply, L1 (L), L2, L3 (N) and L1, L2, L3 for three phase 400V supply. Motor cable must be connected to TM1 terminals. T1, T2, T3.

**Warning:** Connection of supply line cable to terminals T1, T2 & T3 will result in serious damage to the drive components.



**Example power connections: inverter with dedicated power line.**

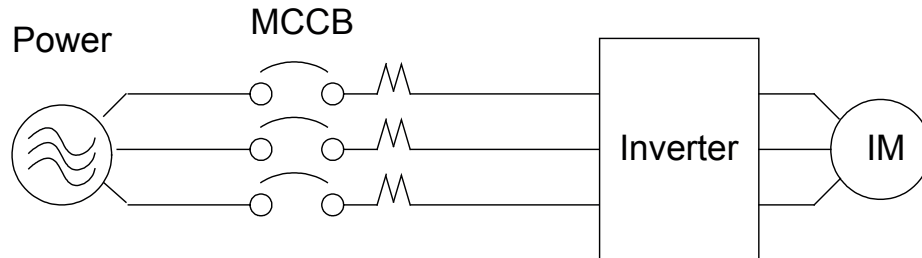

Install a supply RFI filter or Isolation transformer when the power source is shared with other high power electrical equipment as shown below.

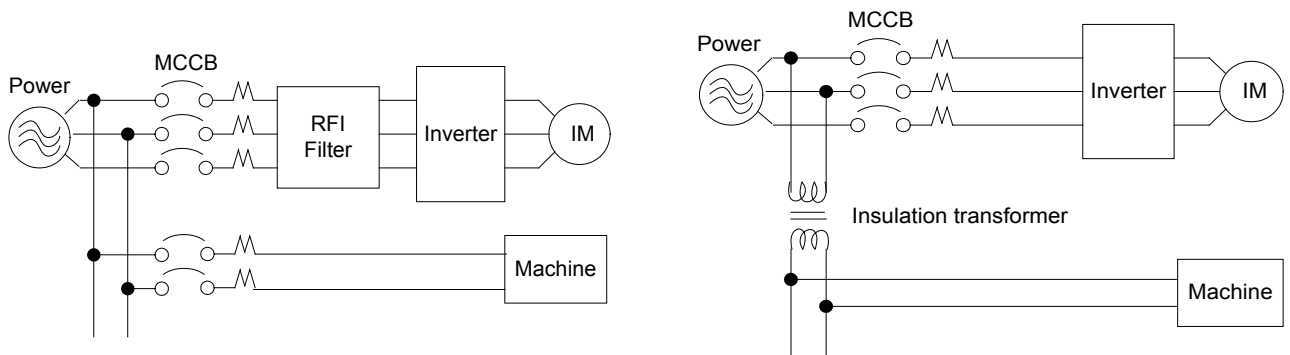

The maximum rms symmetrical amperes and voltage are listed as follows

Device Rating		Short circuit Rating	Maximum Voltage
Voltage	HP		
220V	0.2~3	5000A	240V
440V	1~3	5000A	480V

Electrical ratings of terminals

Horse power	Power Specification	Voltage (Volt)	Current(A)
0.25/0.5/1	220V	300	30
2/3	220V		30
1/2/3	440V	600	28



### 3.3.2. Control Cable selection and Wiring

---

Control cables should be connected to terminal block TM2.

Choose power & control cables according to the following criteria:

- Use copper wires with correct diameter and temperature rating of 60/75°C.
- Minimum cable voltage rating for 200V type inverters should be 300VAC.
- Route all cables away from other high voltage or high current power lines to reduce interference effects.

Use a twisted pair shielded cable and connect the shield (screen) wire to the ground terminal at the inverter end only. Cable length should not exceed 50 meters.

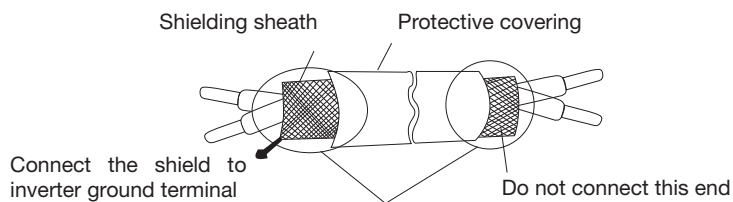

### 3.3.3. Wiring and EMC Guidelines.

For effective interference suppression, do not route power and control cables in the same conduit or trucking. To prevent radiated noise, motor cable should be put in a metal conduit. Alternatively an armored or shielded type motor cable should be used.

For effective suppression of noise emissions the cable armor or shield must be grounded at both ends to the motor and the inverter ground. These connections should be as short as possible. Motor cable and signal lines of other control equipment should be at the least 30 cm apart.

RVLf has a built in Class “A” EMC filter to first environment restricted. (Category C2).

For some installations such as residential, (Category C1) an optional external Class “B” type filter will be necessary. Please consult your local supplier.

#### Typical Wiring.

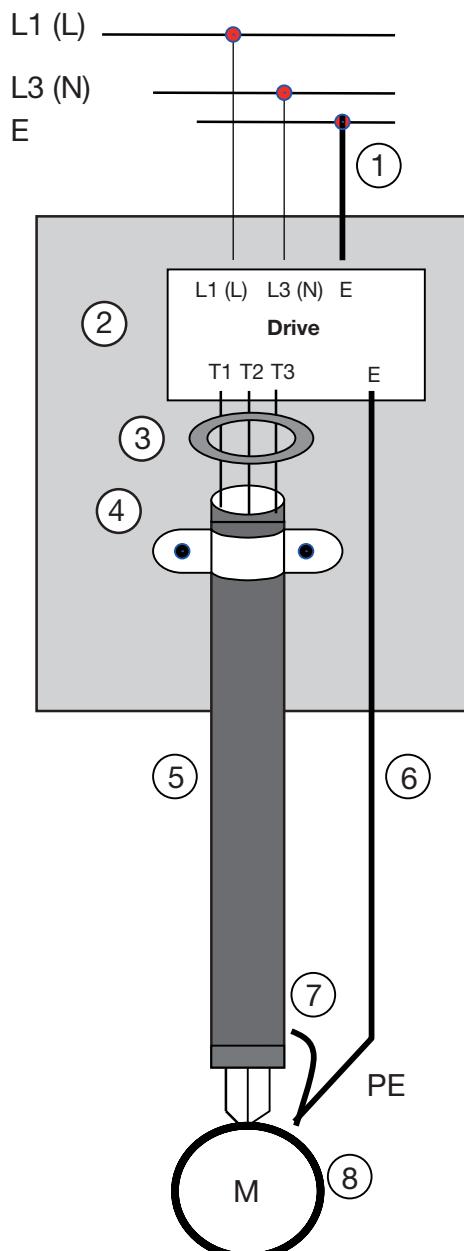

1. Protective earth conductor.  
Conductor size for enclosure & back plate must comply with the local electrical standards. Min 10mm<sup>2</sup>.
2. Back plate. Galvanised steel (Unpainted).
3. Ferrite core / Output reactor ferrite cores can be used to reduce radiated noise due to long motor cables. If ferrite core is used loop motor wires, 3 times round the core. Install core as close to the inverter as possible.

Output reactors provide additional benefit of reducing dv/dt for protection of motor windings.

4. Metal cable clamp. no more than 150mm from the inverter.
- Note: If no enclosure & back plate is used then connect the cable shield by a good 360° termination to the Inverter output terminal E.
5. Screened (Shielded four core cable).
6. Separate protective earth wire, routed outside motor cable separated be at least 100mm.

Note: this is the preferred method specially for large output cables and long length. Multi core screened (3 core & protective earth) can be used for small power and short length.

7. Connect the cable shield by a good 360° termination and connect to the motor protective earth terminal. This link must be as short as possible.
8. Motor earth terminal (Protective Earth).



### 3.3.4. Failure Liability

---



- Carlo Gavazzi bears no responsibility for any failures or damages caused to the inverter if the recommendations in this instruction manual have not been followed specifically points listed below.
- If a correctly rated fuse or circuit breaker has not been installed between the power source and the inverter.
- If a magnetic contactor, a phase capacitor, burst absorber and LC or RC circuits have been connected between the inverter and the motor.
- If an incorrectly rated three-phase squirrel cage induction motor has been used

**Note:**

When one inverter is driving several motors, the total current of all motors running simultaneously must be less than the rated current of the inverter, and each motor has to be equipped with a correctly rated thermal overload relay.

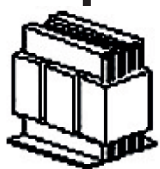
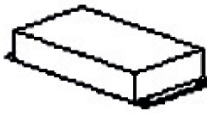
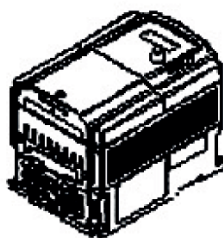
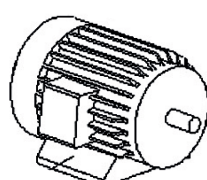

### 3.3.5. Considerations for Peripheral Equipment

	<p>Power</p>	<p>Ensure that the supply voltage is correct. A molded-case circuit breaker or fused disconnect must be installed between the AC source and the inverter.</p>
	<p>Circuit Breaker &amp; RCD</p>	<p>Use a molded-case circuit breaker that conforms to the rated voltage and current of the inverter. Do not use the circuit breaker as the run/stop switch for the inverter. Residual Current Circuit Breaker (RCD). Current setting should be 200mA or above and the operating time at 0.1 second or longer to prevent malfunctions.</p>
	<p>Magnetic contactor</p>	<p>Normally a magnetic contactor is not needed. A contactor can be used to perform functions such as external control and auto restart after power failure. Do not use the magnetic contactor as the run/stop switch for the inverter.</p>
	<p>AC reactor for power quality improvement</p>	<p>When a 200V/400V inverter with rating below 15KW is connected to a high capacity power source (600KVA or above) then an AC reactor can be connected for power factor improvement and reducing harmonics.</p>
	<p>Input noise filter</p>	<p>RVLF inverter has a built-in filter to Class “A” first Environment. (CategoryC2). To satisfy the required EMC regulations for your specific application you may require an additional EMC filter.</p>
	<p>Inverter</p>	<p>Connect the single phase power to Terminals, L1 (L) &amp; L3(N) and three phase power to Terminals: (200V: L1 (L), L2, L3 (N) or 400V: L1, L2, L3) Warning! Connecting the input terminals T1, T2, and T3 to AC input power will damage the inverter. Output terminals T1, T2, and T3 are connected to U, V, and W terminals of the motor. To reverse the motor rotation direction just swap any two wires at terminals T1, T2, and T3. Ground the Inverter and motor correctly. Ground resistance for 200V power &lt;100 Ohms.</p>
	<p>Motor</p>	<p>Three-phase induction motor. Voltage drop on motor due to long cable can be calculated. Volts drop should be &lt; 10%. Phase-to-phase voltage drop (V)= 3 ×resistance of wire (Ω/km) ×length of line (m) × current × 10-3</p>



### 3.3.6. Ground Connection

Inverter ground terminal must be connected to installation ground correctly and according to the required local wiring regulations.

- Ground cable size must be according to the required local wiring regulations. Ground connection should be as short as possible.
- Do not share the ground of the inverter with other high current loads (welding machine, high power motors). Ground each unit separately.
- Ensure that all ground terminals and connections are secure
- Do not make ground loops when several inverters share a common ground point.

**Note:**

Please leave at least 5cm while installing inverter side by side in order to provide enough cooling space.

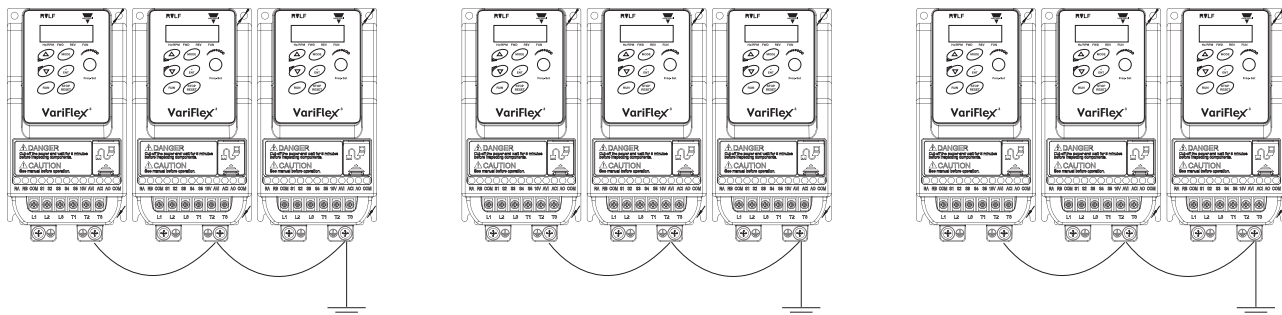

### 3.3.7. Inverter Exterior

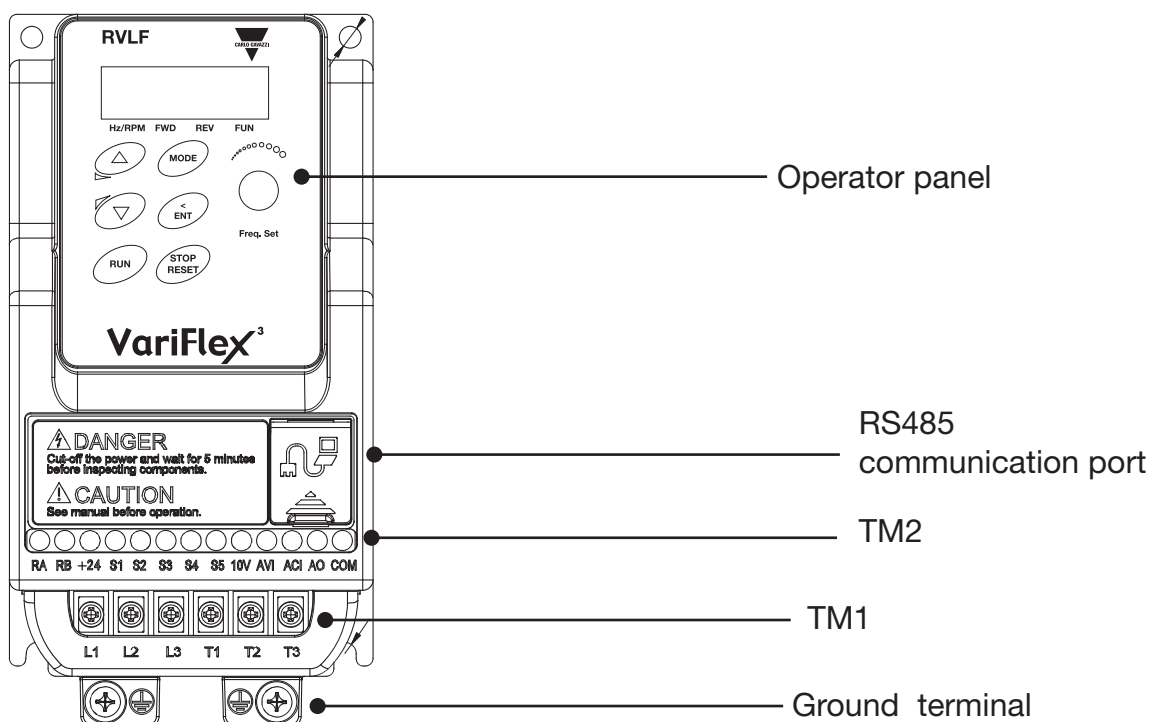





### 3.4. Specifications

#### 3.4.1. Inverter exterior

100V Class: Single phase.

<b>Model: RVLf</b>	110040	110075
<b>Horse power (HP)</b>	0.5	1
<b>Suitable motor capacity (KW)</b>	0.4	0.75
<b>Rated output current (A)</b>	2.6	4.3
<b>Rated capacity (KVA)</b>	1.00	1.65
<b>Input voltage range(V)</b>	Single Phase: 110~120V, 50/60HZ	
<b>Allowable voltage fluctuation</b>	+10%-15%	
<b>Output voltage range(V)</b>	Three Phase: 0~240V	
<b>Input current (A)</b>	13	19
<b>Allowable momentary power loss time (S)</b>	1.0	1.0
<b>Enclosure</b>	IP20	

200V Class: Single phase.

F: Built-in Filter

<b>Model: RVLf</b>	120040	120075	120150	120220
<b>Horse power (HP)</b>	0.5	1	2	3
<b>Suitable motor capacity (KW)</b>	0.4	0.75	1.5	2.2
<b>Rated output current (A)</b>	2.6	4.3	7.5	10.5
<b>Rated capacity (KVA)</b>	1.00	1.65	2.90	4.00
<b>Input voltage range(V)</b>	Single Phase: 200~240V, 50/60HZ			
<b>Allowable voltage fluctuation</b>	+10%-15%			
<b>Output voltage range(V)</b>	Three Phase: 0~240V			
<b>Input current (A)</b>	7.2	11	15.5	21
<b>Allowable momentary power loss time (S)</b>	1.0	1.0	2.0	2.0
<b>Enclosure</b>	IP20			

200V Class: Three phase.

<b>Model: RVLf</b>	320040	320075	320150	320220
<b>Horse power (HP)</b>	0.5	1	2	3
<b>Suitable motor capacity (KW)</b>	0.4	0.75	1.5	2.2
<b>Rated output current (A)</b>	2.6	4.3	7.5	10.5
<b>Rated capacity (KVA)</b>	1.00	1.65	2.90	4.00
<b>Input voltage range(V)</b>	Single Phase: 200~240V, 50/60HZ			
<b>Allowable voltage fluctuation</b>	+10%-15%			
<b>Output voltage range(V)</b>	Three Phase: 0~240V			
<b>Input current (A)</b>	4.0	6.4	9.4	12.2
<b>Allowable momentary power loss time (S)</b>	1.0	1.0	2.0	2.0
<b>Enclosure</b>	IP20			



400V Class: Three phase.

F: Built-in Filter

<b>Model: RVLf</b>	340075	340150	340220
<b>Horse power (HP)</b>	1	2	3
<b>Suitable motor capacity (KW)</b>	0.75	1.5	2.2
<b>Rated output current (A)</b>	2.3	3.8	5.2
<b>Rated capacity (KVA)</b>	1.7	2.9	4.0
<b>Input voltage range(V)</b>	Three phase: 380~480V, 50/60HZ		
<b>Allowable voltage fluctuation</b>	+10%		
<b>Output voltage range(V)</b>	Three phase 0~480V		
<b>Input current (A)</b>	4	5.6	7.3
<b>Allowable momentary power loss time (S)</b>	2	2.0	2.0
<b>Enclosure</b>	IP20		

<b>Model: RVLf</b>	340370	340550	340750	3401100
<b>Horse power (HP)</b>	5.0	7.5	10	15
<b>Suitable motor capacity (KW)</b>	3.7	5.5	7.5	11
<b>Rated output current (A)</b>	9.2	13	17.5	24
<b>Rated capacity (KVA)</b>	7.01	9.91	13.34	18.29
<b>Input voltage range(V)</b>	Three phase: 380~480V, 50/60HZ			
<b>Allowable voltage fluctuation</b>	+10%-15%			
<b>Output voltage range(V)</b>	Three phase 0~480V			
<b>Input current (A)</b>	10.1	14.3	19.3	26.4
<b>Allowable momentary power loss time (S)</b>	2.0	2.0	2.0	2.0
<b>Enclosure</b>	IP20			



### 3.4.2. General Specifications

Item		RVLF
<b>Control Mode</b>		V/F Control + SLV
<b>Frequency</b>	Range	0.01~599.00Hz
	Speed Accuracy (100% torque)	V/F: 3% SLV: 1%
	Setting	Keypad: Set directly with keys or the VR (Potentiometer) on the keypad
		External input terminals: AVI (0/2~10V), ACI (0/4~20mA) input Multifunction input up/down function (Group 3)
		Setting frequency by communication method.
Frequency limit	Lower and upper frequency limits 3 -skip frequency settings.	
<b>Run</b>	Operation set	Keypad run, stop button
		External terminals: Multi-operation-mode 2 / 3 wire selection Jog operation
		Run command by communication method.
<b>Main Controls</b>	V / F curve setting	6 fixed curve and one customized curve
	Carrier frequency	1~16KHz (default 5KHz)
	Acceleration and deceleration control	2 off Acc / dec time parameters. 4 off S curve parameters.
	Multifunction input	19 functions (refer to description on group3)
	Multifunction output	14 functions (refer to description on group3)
	Multifunction analog output	5 functions (refer to description on group4)
	Main features	Overload detection, 8 preset speeds, auto-run, Acc/Dec switch (2 Stages), Main/Alt run command select, main/alt frequency Command select, PID control, torque boost, V/F start frequency, fault reset.



<b>Display</b>	LED	Display: parameter/parameter value/frequency/line speed/ DC voltage/output voltage/output current/PID feedback/ input and output terminal status/heat sink temperature/Program version/Fault Log.
	LED Status indicator	For run/stop/forward and reverse.
<b>Protective Functions</b>	Overload protection	Integrated motor and Inverter overload protection. (150% rated current for 60s, every 10minutes)
	Over voltage	100V/200V: Over 410V, 400V: Over 820V
	Under voltage	100V/200V: Under 190V, 400V: Under 380V
	Momentary power loss restart	Inverter auto-restart after a momentary power loss.
	Stall prevention	Stall prevention for acceleration / deceleration / and continuous run.
	Short-circuit output terminal	Electronic circuit protection
	Grounding fault	Electronic circuit protection
	Additional protective functions	Heak sink over temperature protection, auto carrier frequency reduction with temperature rise, fault output, reverse prohibit, number of auto restart attempts, parameter lock
<b>International Certification</b>		CE/UL
<b>Communication</b>		RS485 (Modbus) built in, with one to one or one to many control.
<b>Environment</b>	Operating temperature	-10~50°C
	Storage temperature	-20~60°C
	Humidity	Under 95%RH (no condensation)
	Vibration	0.075mm Amplitude for 10Hz to 57Hz 1G for 57Hz to 150Hz
	EMC compliance	EN61800-3, First Environment Present models can pass C1 level with grounding kit
	LVD compliance	EN 61800-5-1
	Electrical safety	UL508C
	Protection level	IP20



### 3.5. Standard wiring

#### 3.5.1. Single phase (NPN input)

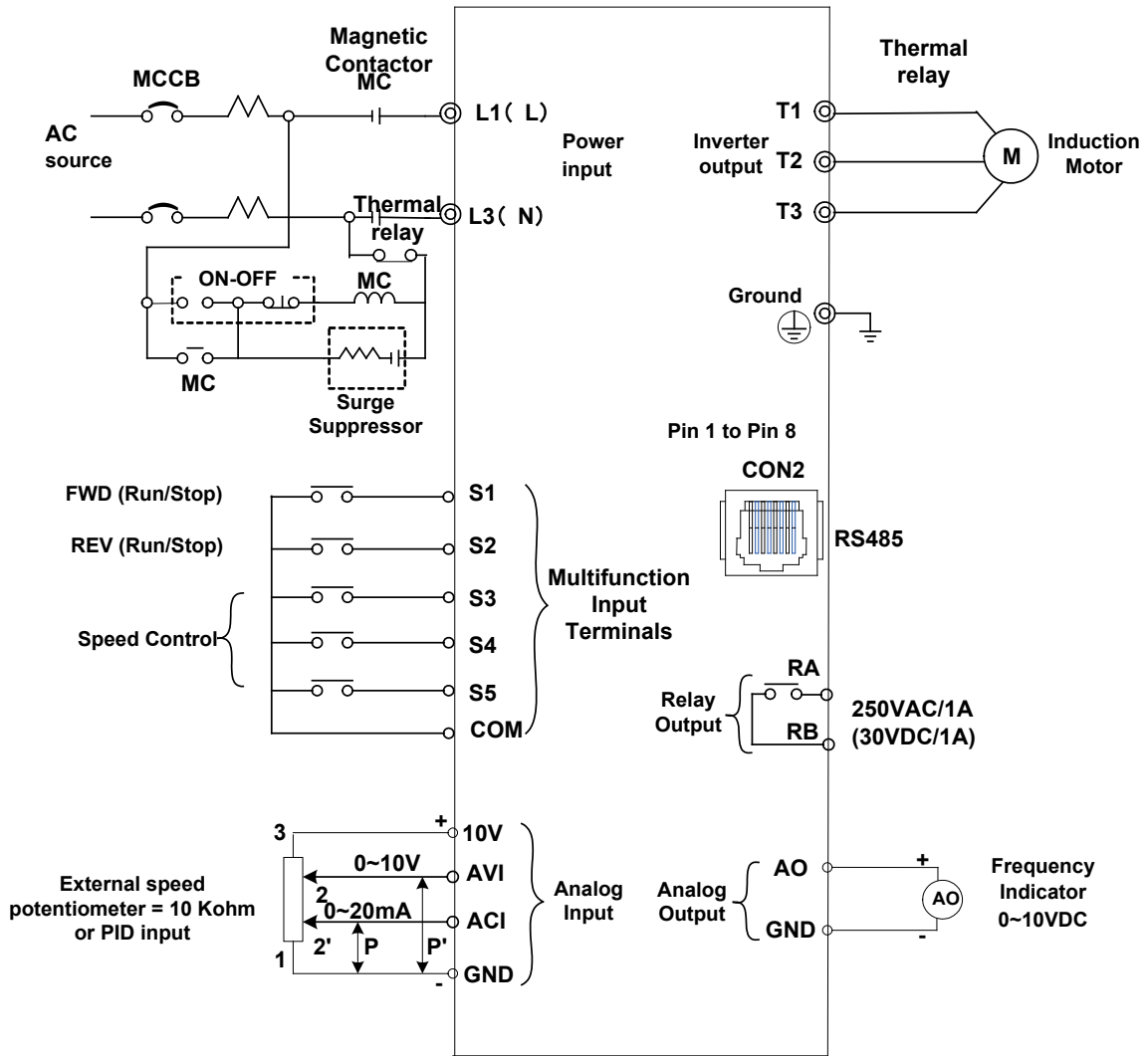

**Model:**

100V: RVLFA110040A, RVLFA110075A



### 3.5.2. Single phase (PNP Input)

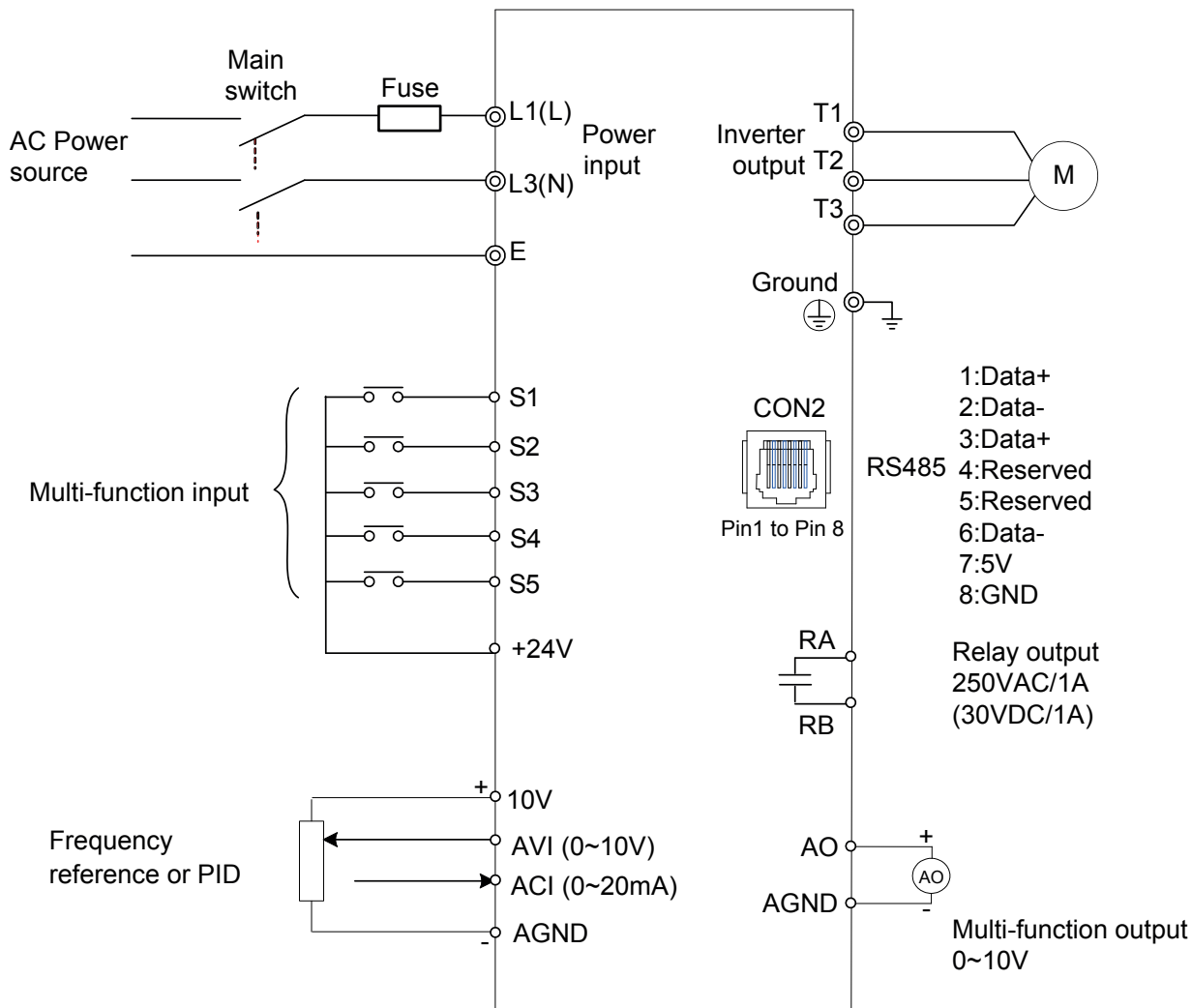

**Model:**

200V: RVLFA120040FA / RVLFA120075FA / RVLFB120150FA / RVLFB120220FA



### 3.5.3.Three phase (NPN Input)

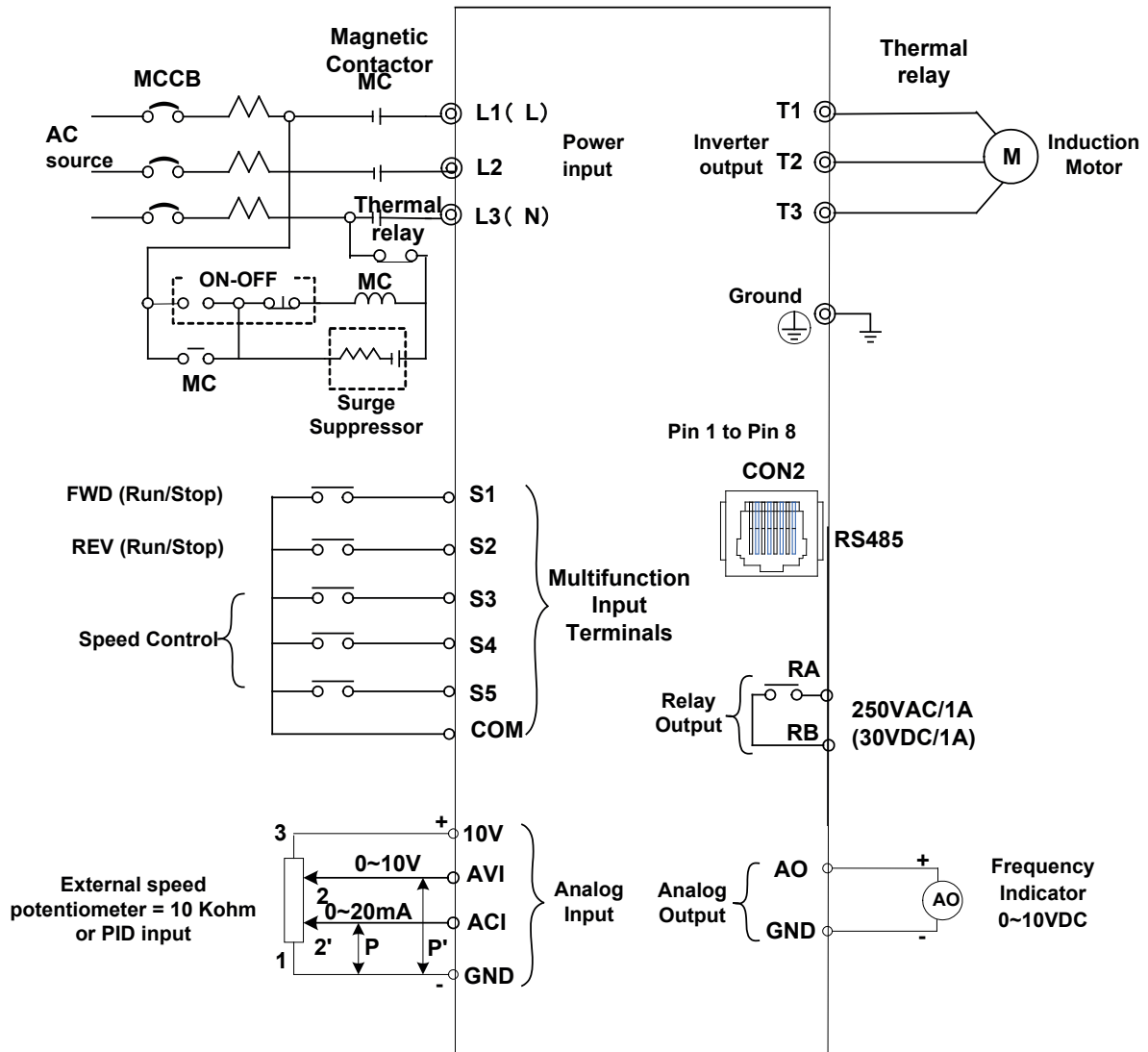

**Model:**

200V: RVLFA320040A, RVLFA320075A, RVLFB320150A, RVLFB320220A



### 3.5.4. Three phase (PNP Input)

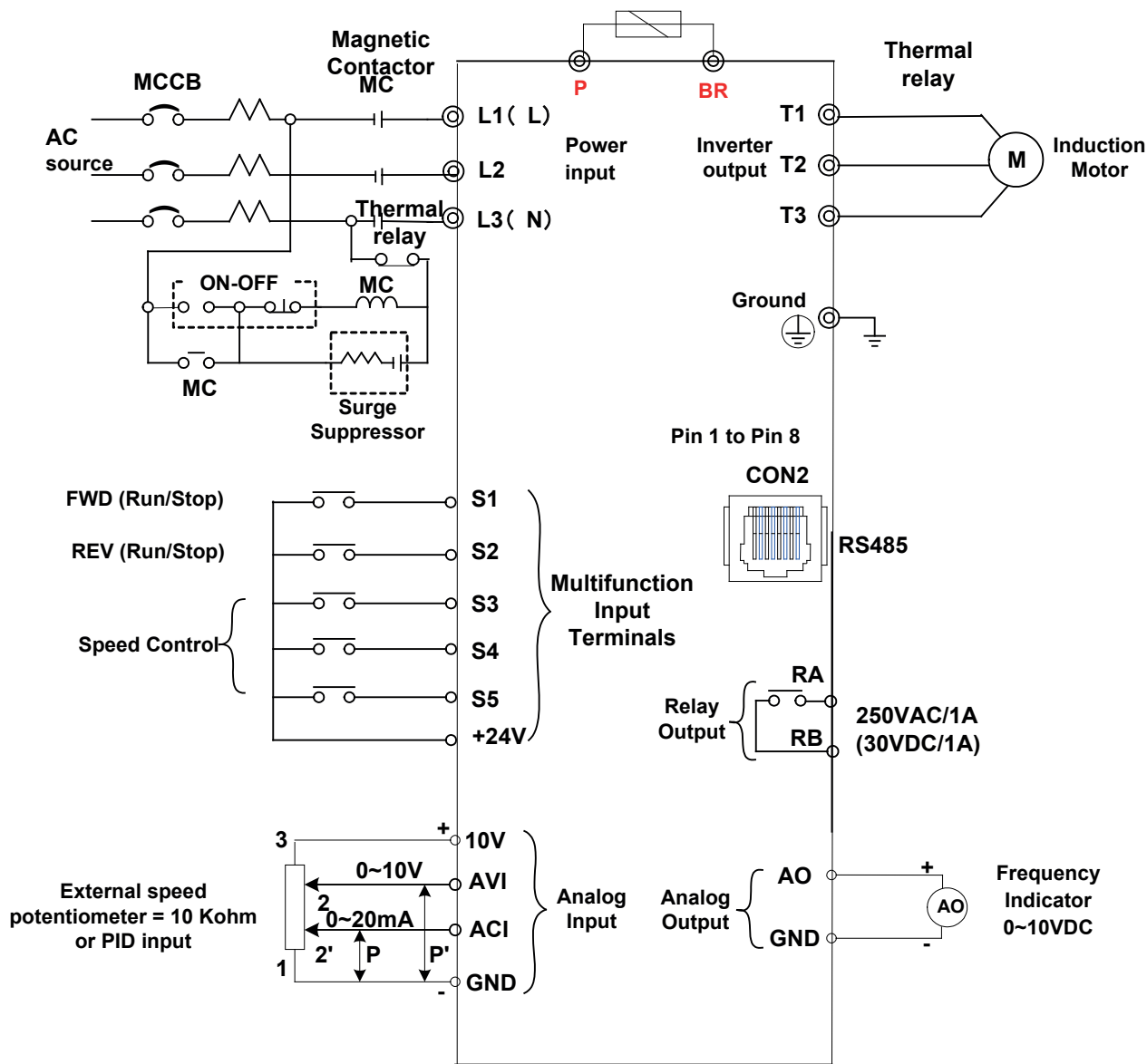

**Model:**

400V: RVLFB340075FA, RVLFB340150FA, RVLFB340220FA





### 3.5.5. Three phase (PNP / NPN)

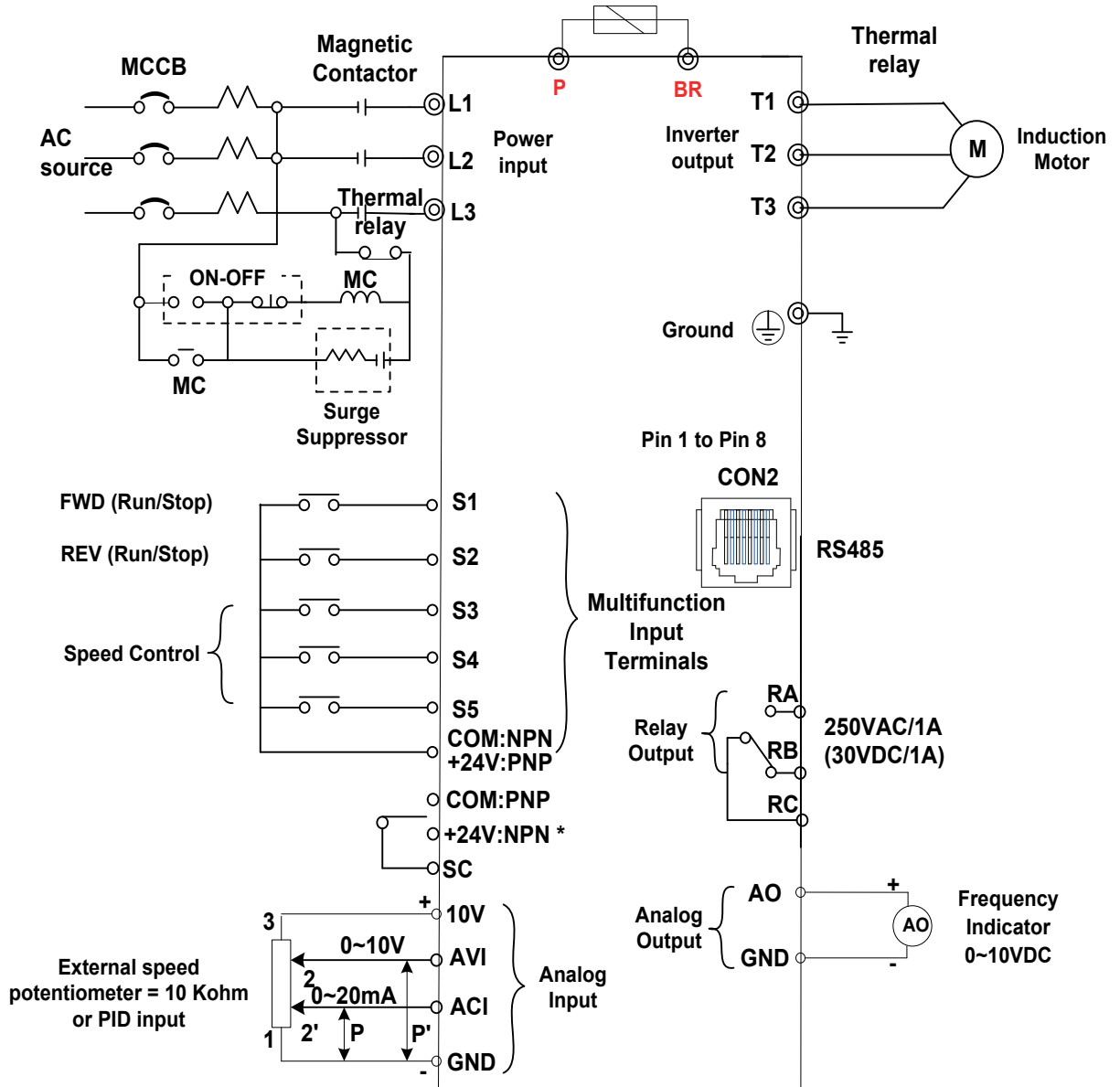

**Model:**

400V: RVLFC340370FA, RVLFC3405500FA, RVLFD340750FA, RVLFD3401100FA



### 3.6. Terminal Description

#### 3.6.1. Terminal Description

Terminal symbols	TM1 Function Description
L1(L)	Main power input, Single Phase L1(L)/ L3(N) Three Phase (200V): L1(L)/ L2/ L3 (N) Three Phase (400V): L1/ L2/ L3
L2	
L3(N)	
P*	Externally connected braking resistor
BR*	
T1	Inverter output, connect to U, V, W terminals of motor
T2	
T3	
	Ground terminal

\*P, BR for 400V series

#### Single phase (200V series)

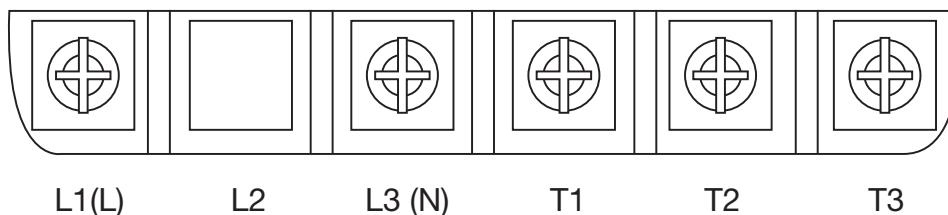

Note: the screw on L2 terminal is removed for the single phase input supply models.

#### Three phase (200V series)

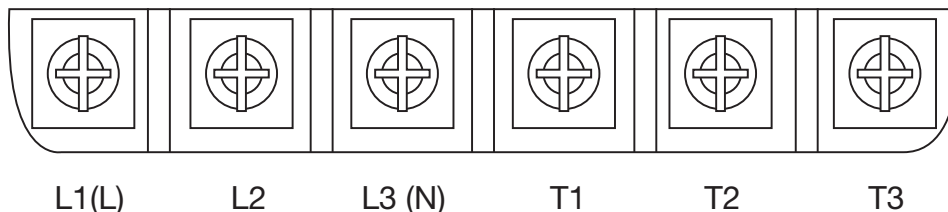

#### Three phase (400V series)

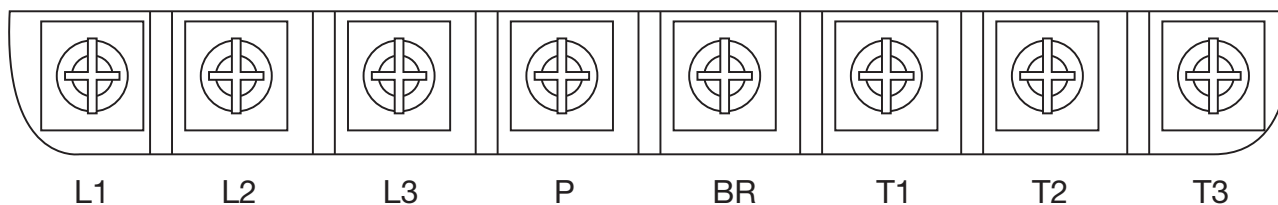



### 3.6.2. Control Circuit Terminal Description

#### Frame A & B

Terminal	TM1 Function Description	Signal Level
RA	Relay output terminal, Specification: 250VAC/1A (30VDC/1A)	250VAC/ 1A (30VDC/ 1A)
RB		
COM	S1~S5 (COMMON) NPN	+/-15%, Max output 30mA
+24V	S1~S5 (COMMON) PNP	+/-15%, Max output 30mA
S1	Multi-function input terminals (refer to group3)	24VDC, 4.5mA, optical coupling isolation (Max voltage 30VDC, Input impedance 6kΩ)
S2		
S3		
S4		
S5		
10V	Built in power for an external speed potentiometer	10V (Max current 20mA)
AVI	Analog voltage input, specification: 0~10VDC/ 2-10V	0-10V (Input impedance 200kΩ)
ACI	Analog current input, specification: 0/4~20mA	0-20mA (Input impedance 499kΩ)
AO	Multi function analog output terminal. Maximum output 10VDC/1mA	0-10V(Max current 2mA)
AGND	Analog ground terminal	

**PNP:**

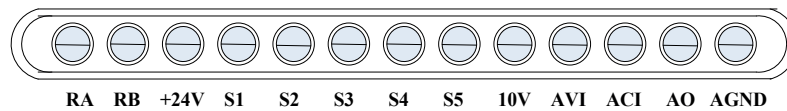

**PNP:**

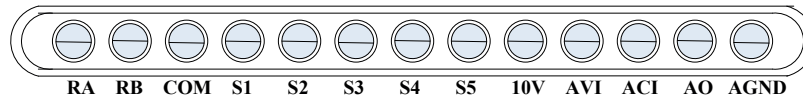



Frame C & D

Terminal	TM1 Function Description	Signal Level
RA	Relay output terminal, Specification: 250VAC/1A (30VDC/1A) RA-NO; RB-NC; RC-Common	250VAC/ 1A (30VDC/ 1A)
RB		
RC		
+24V	S1~S5 (COMMON) PNP	+/-15%, Max output 30mA
SC	PNP input: COM&SC needs shorted	
S1	Multi-function input terminals (refer to group 3)	24VDC, 4.5mA, optical coupling isolation (Max voltage 30VDC, Input impedance 6kΩ)
S2		
S3		
S4		
S5		
10V	Built in power for an external speed	10V (Max current 20mA)
AVI/PTC	Analog voltage input, specification: 0~10VDC/ 2-10V	0-10V (Input impedance 200kΩ)
ACI	Analog current input, specification: 0/4~20mA	0-20mA (Input impedance 499kΩ)
AO	Multi-function analog output terminal. Maximum output 10VDC/1mA	0-10V(Max current 2mA)
AGND	Analog ground terminal	

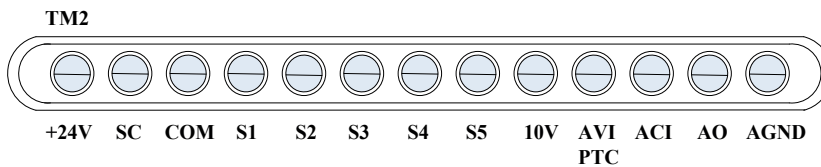
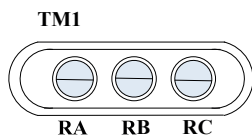



### 3.7. Outline Dimensions

Size A

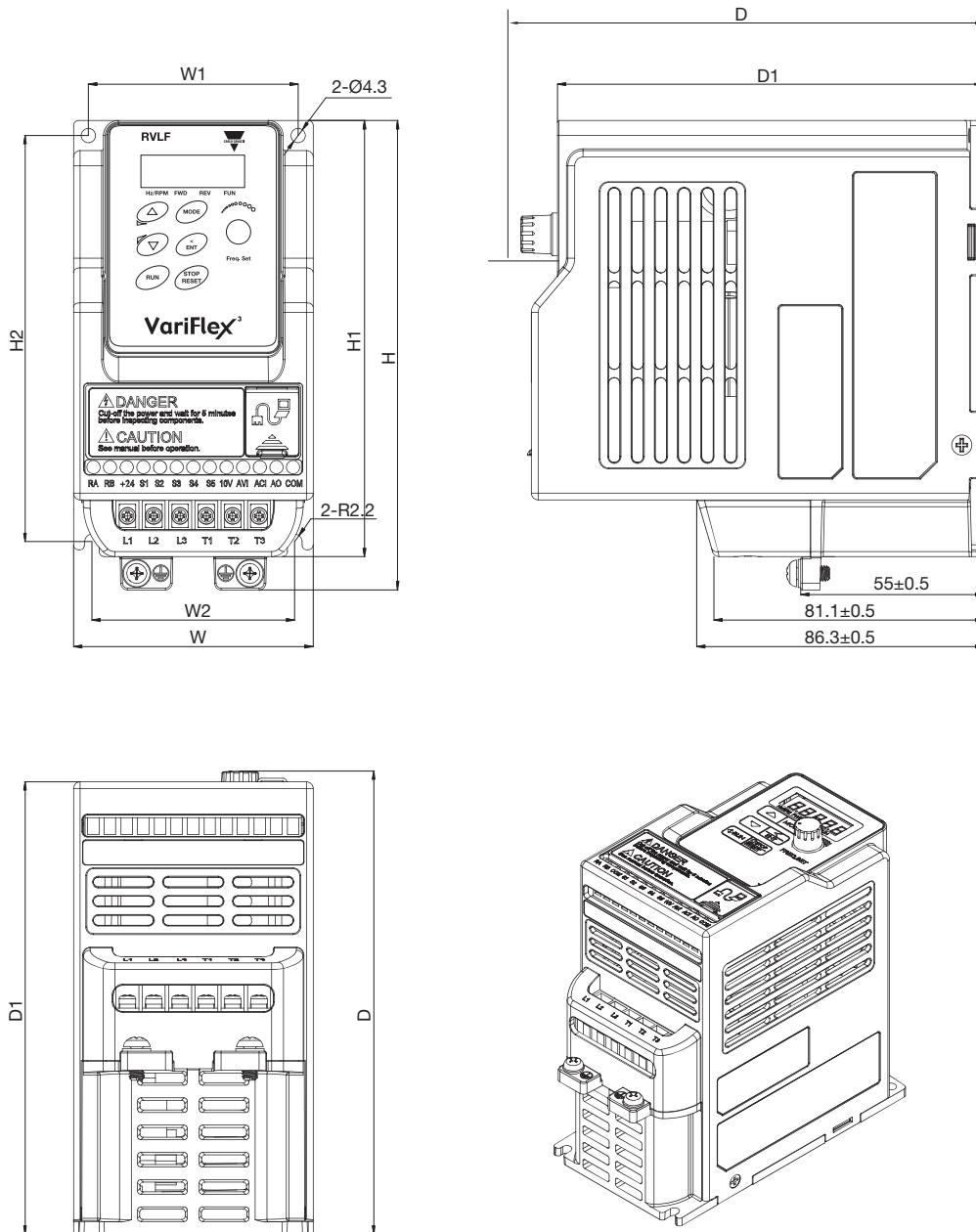

Model	W	W1	W2	H	H1	H2	D	D1	D2	E	E1	E2
RVLFA120040FA	72	63	61	141	131	122	144.2	136	128.2	86.3	81.1	55
RVLFA120075FA												
RVLFA320040A												
RVLFA320075A												
RVLFA110040A												
RVLFA110075A												

F: Built-in EMC filter



Size B

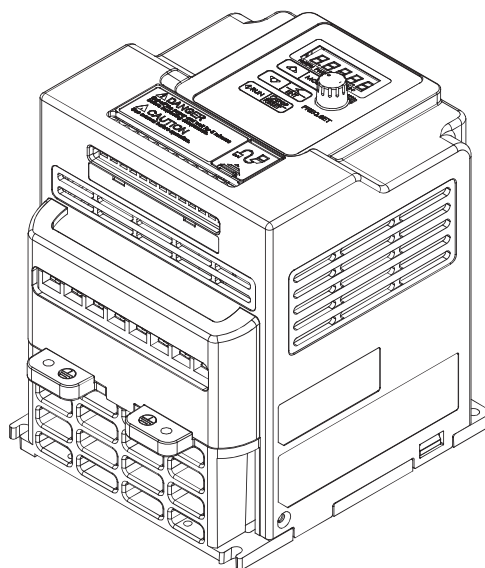
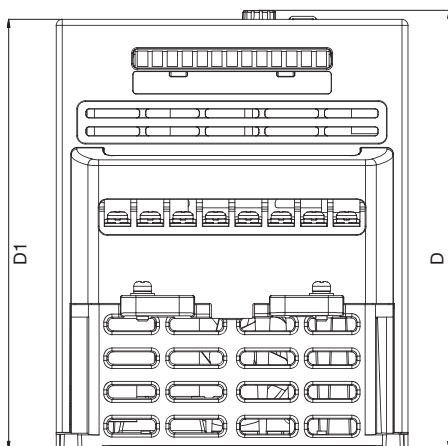
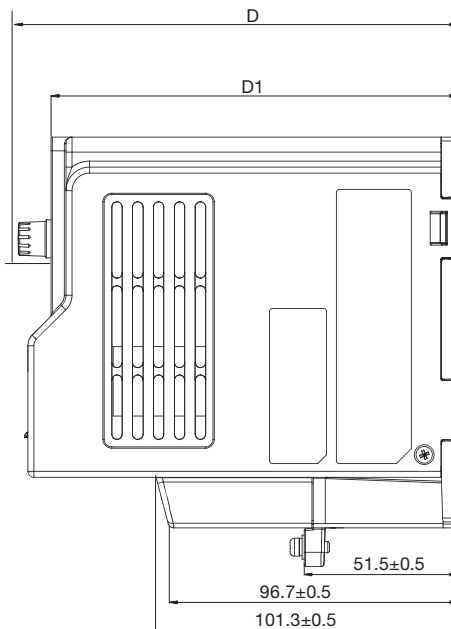
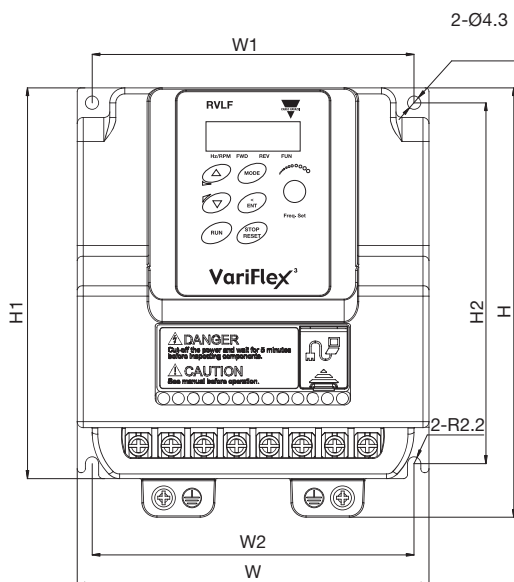

Model	W	W1	W2	H	H1	H2	D	D1	D2	E	E1	E2
RVLFB120150FA	118	108	108	144	131	121	152.2	144.2	136.4	101.3	96.7	51.5
RVLFB120220FA												
RVLFB320040A												
RVLFB320075A												
RVLFB340075FA												
RVLFB340150FA												
RVLFB340220FA												

F: Built-in EMC filter

Size C and D

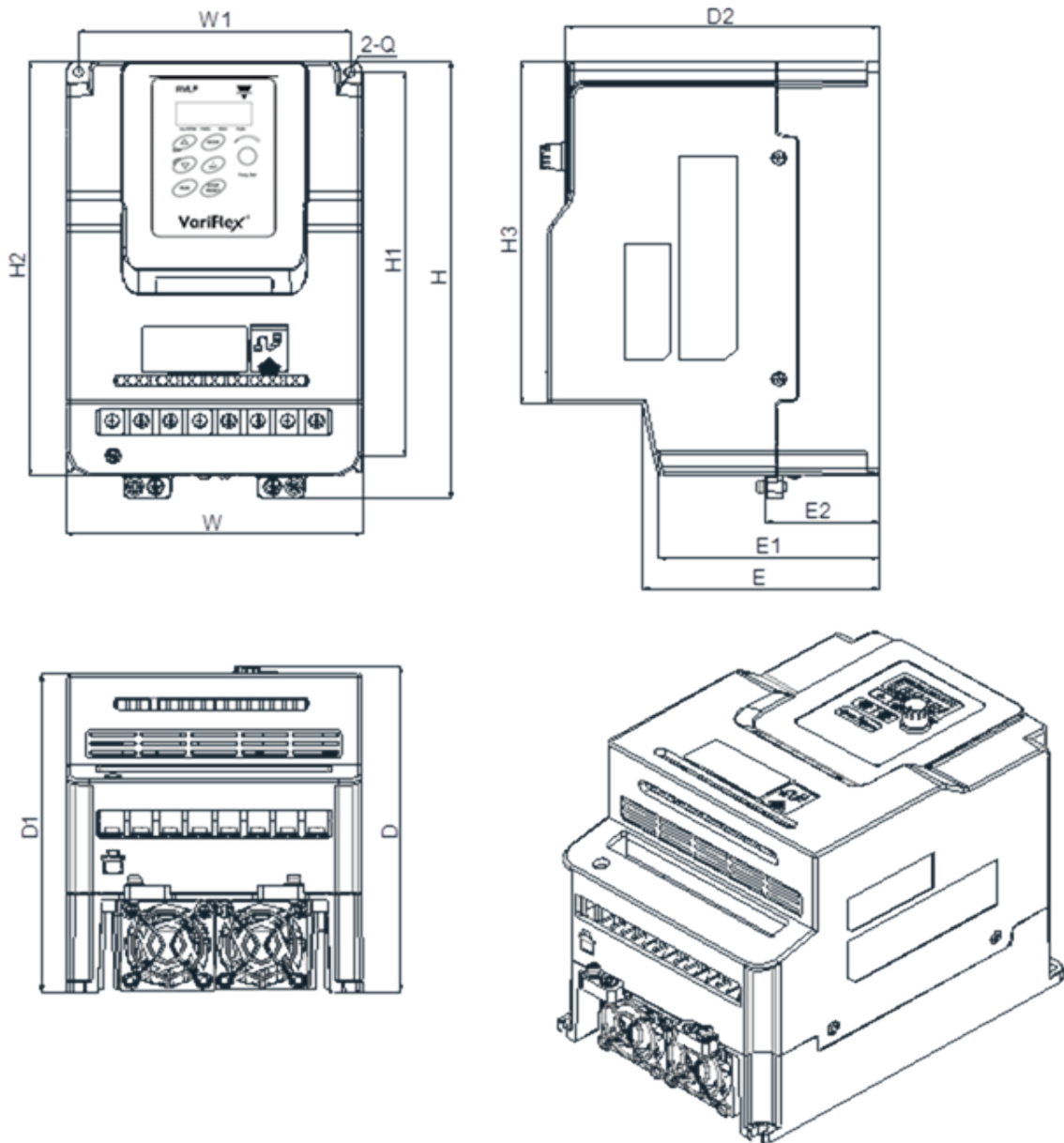

Model	W	W1	W2	H	H1	H2	D	D1	D2	E	E1	E2
RVLFC340370FA	129	118	197.5	177.6	188	154	148	143.7	136	102.6	96	48.2
RVLFC340550FA												
RVLFD340750FA	187	176	273	249.8	261	228.6	190	185.6	177.9	136	84.7	-
RVLFB3401100FA												

F: Built-in EMC filter

### 3.8. Filter Disconnection

---

EMC filter may be disconnected:

Inverter drives with built-in EMC filter are not suitable for connection to certain type of supply systems, such as listed below; in these cases the RFI filter can be disabled.

In all such cases consult your local electrical standards requirements.

#### **IT type supply systems (ungrounded) & certain supply systems for medical equipment.**

For ungrounded supply systems if the filter is not disconnected the supply system becomes connected to earth through the Y capacitors on the filter circuit. This could result in danger and damage to the drive.

#### **Disconnection steps:**

1. Remove EMC filter protection cover by screwdriver.
2. Remove EMC line by pliers.

**Note:** Disconnecting the EMC filter link will disable the filter function, please consult your local EMC standards requirement.

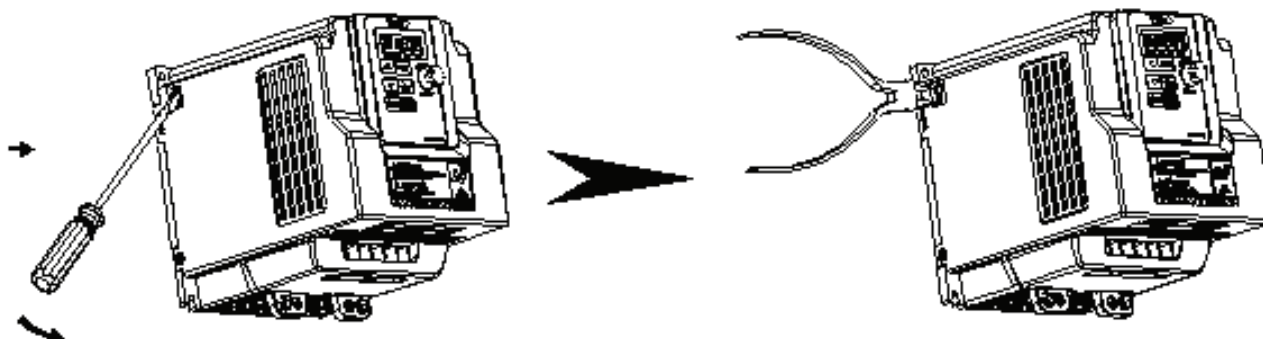

#### **Warning:**

Inverter drives with built-in EMC filter are not suitable for connection to certain type of supply connections, such as listed below, in these cases the RFI filter can be disabled. In all such cases consult your local electrical standards requirements.

IT type supply systems (ungrounded), corner grounded type TN systems certain supply system for medical equipment.

For european type supply systems. The following link is very useful, please see section 3.8 mains type.





## 4. Software Index

### 4.1. Keypad Description

#### 4.1.1. Operator Panel Functions

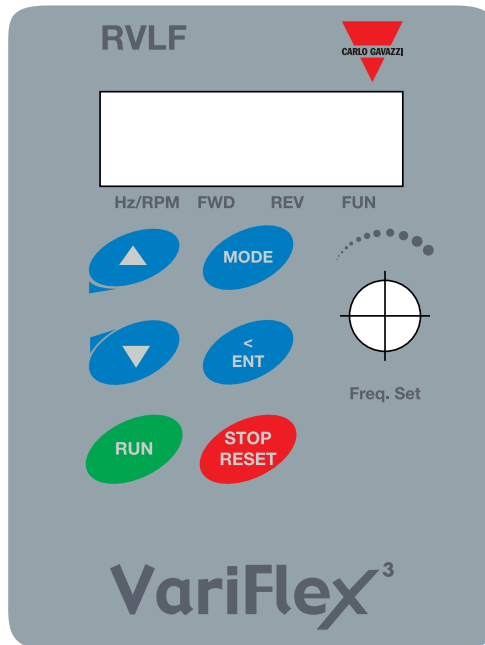

Type	Item	Function
Digital display & LEDs	Main digital displays	Frequency display, parameter, voltage, current, temperature, fault messages.
	LED Status	Hz/RPM: ON when the frequency or line speed is displayed. OFF when the parameters are displayed. FWD: ON while the inverter is running forward. Flashes while stopped. REV: ON while the inverter is running reverse. Flashes while stopped. FUN: ON when the parameters are displayed. OFF when the frequency is displayed.
Variable Resistor	FREQ SET	Used to set the frequency
Keys On Keypad	RUN	RUN: Run at the set frequency.
	STOP/RESET (Dual function keys)	STOP: Decelerate or coast to stop. RESET: Use to reset alarms or resettable faults.
	▲	Increment parameter number and preset values.
	▼	Decrement parameter number and preset values.
	MODE	Switch between available displays
	</ENTER (Dual function keys, a short press for left shift function, a long press for ENTER function)	“<” Left Shift: Used while changing the parameters or parameter values ENTER: Used to display the preset value of parameters and for saving the changed parameter values.



### 4.1.2. Digital Display Description

#### Alpha numerical display format

Digit	LED	Letter	LED	Letter	LED	Symbol	LED
0		A		n		-	
1		b		o		°	
2		C		P		_	
3		d		q		.	
4		E		r			
5		F		S			
6		G		t			
7		H		u			
8		J		V			
9		L		Y			

#### Digital display indication formats

Actual output frequency	Set frequency	
Digits are lit continually	Preset digits flashing	Selected digit flashing



### LED display example

Display	Description
	In stop mode shows the set frequency In run mode shows the actual output frequency
	Selected parameter
	Parameter value
	Output voltage
	Output current in amps
	DC Bus voltage
	Temperature
	PID feedback value
	Error display
	Analogue current / voltage ACID / AVI . Range (0~1000)

### LED Status description

	LED Indicator light status		
Frequency / line speed Indicator	Hz/RPM	On	
Menu mode indicator	FUN	On while not displaying frequency or line speed	
FWD indicator	FWD	On while running forward	Flashing while stopped in forward mode
REV indicator light	REV	On while running reverse	Flashing while stopped in reverse mode



### 4.1.3 Digital Display Set Up

On power up digital display screens will be as shown below.

User selectable display formats:

12-00	Display Mode								
	0 0 0 0 0 High Low Each of the above 5 digits can be set to any of the selections below from 0 to 7								
Range	<table border="0"> <tr> <td>[0]: Disable display</td> <td>[1]: Output current</td> </tr> <tr> <td>[2]: Output voltage</td> <td>[3]: DC voltage</td> </tr> <tr> <td>[4]: Temperature</td> <td>[5]: PID feedback</td> </tr> <tr> <td>[6]: AVI</td> <td>[7]: ACI</td> </tr> </table>	[0]: Disable display	[1]: Output current	[2]: Output voltage	[3]: DC voltage	[4]: Temperature	[5]: PID feedback	[6]: AVI	[7]: ACI
[0]: Disable display	[1]: Output current								
[2]: Output voltage	[3]: DC voltage								
[4]: Temperature	[5]: PID feedback								
[6]: AVI	[7]: ACI								

The highest bit of 12-00 sets the power on the display, other bits set the selected display from range 0-7 as listed above.

Example1: Set parameter 12-00=[10000] to obtain display format shown below.

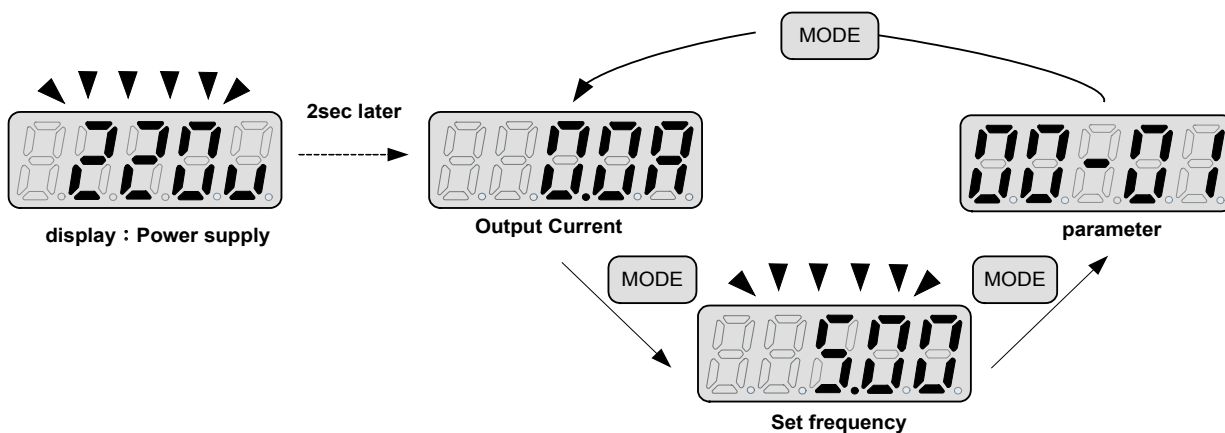



Example 2. Set parameter 2: 12-00=[12345] to obtain the display format shown below.

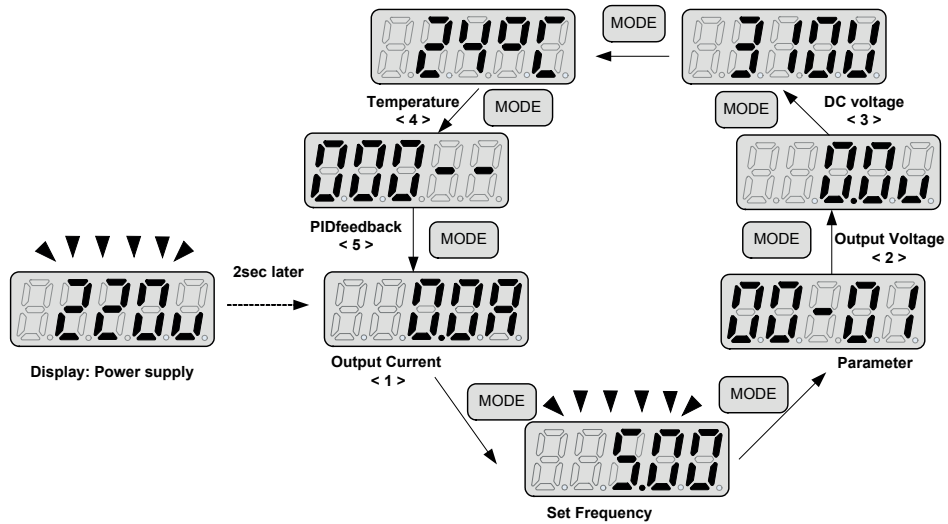

Increment / Decrement key functions:

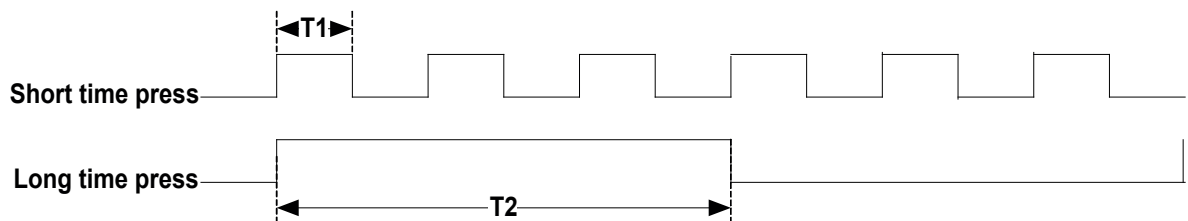

Quick pressing of these keys will increment or decrement the selected digit by one. Extended pressing will increment or decrement the selected digit continuously.

**2. “</ENT” Key functions :**

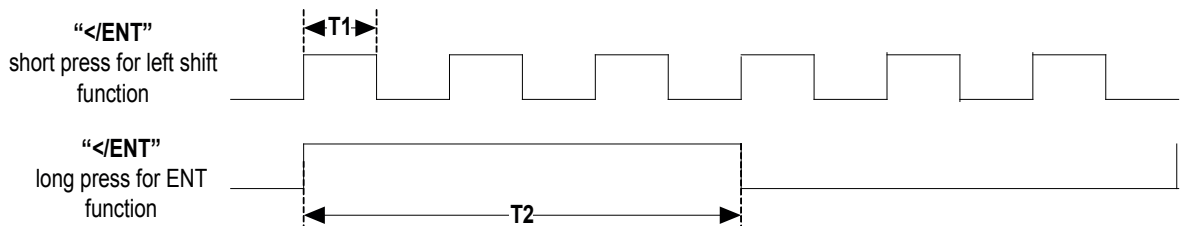

Quick pressing of this key will display the preset value of the parameter selected. Extended pressing of this key will save the altered value of the selected parameter.



### 4.1.4. Example of Keypad Operation

Example1: Modifying parameters

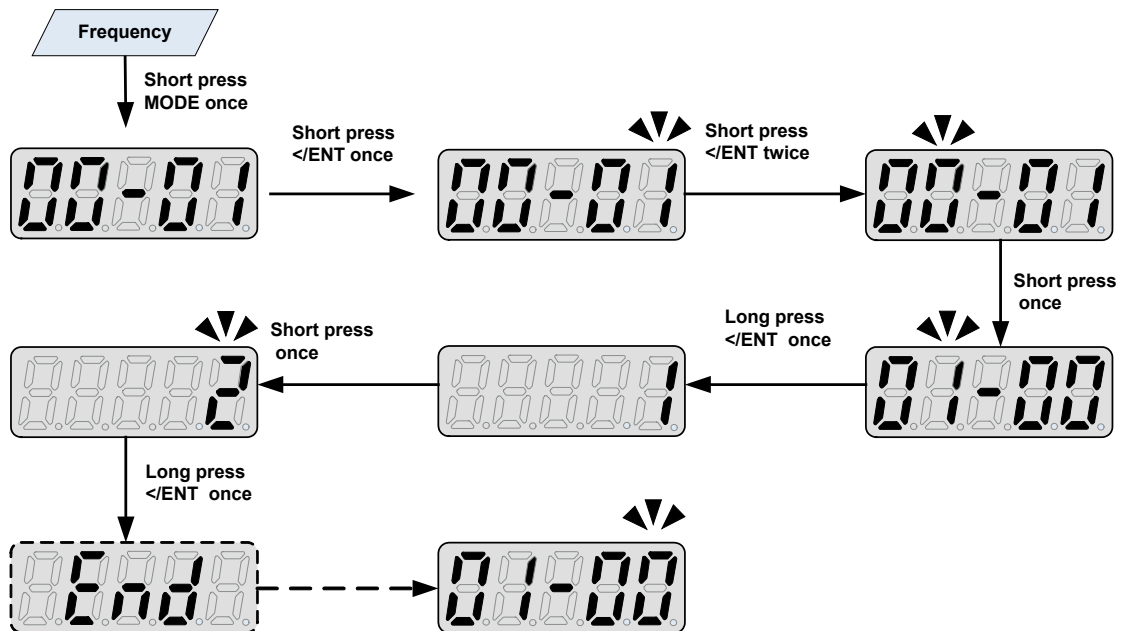



Example 2: Modifying the frequency from keypad in run and stop modes.

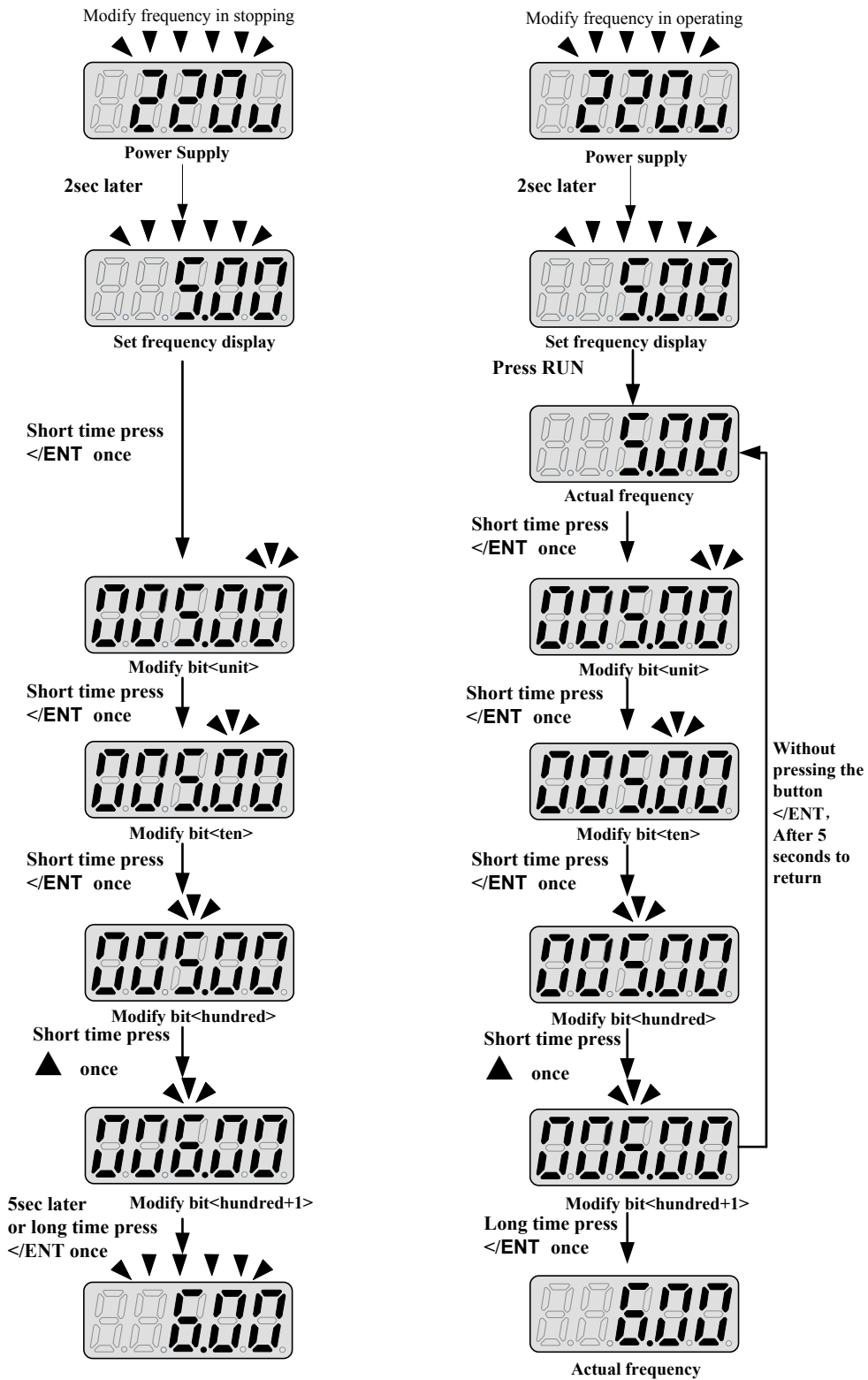

Note: frequency command setting will be limited to the range set by parameters for lower & upper frequency.



### 4.1.5. Operation Control

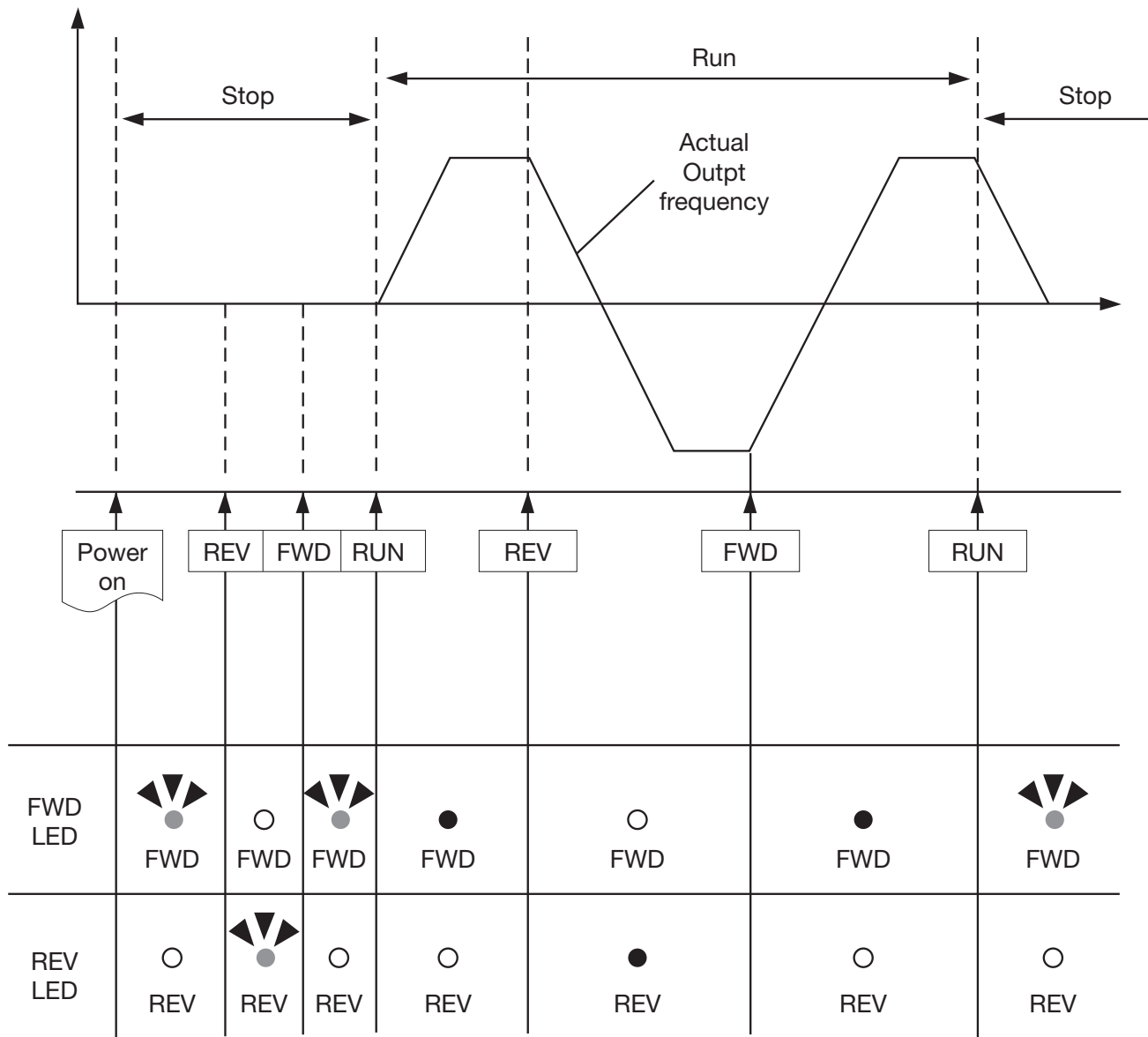





## 4.2. Programmable Parameter Groups

Parameter Group No.	Description
Group 00	Basic parameters
Group 01	V/F Pattern selections & setup
Group 02	Motor parameters
Group 03	Multi function digital Inputs / Outputs
Group 04	Analog signal Inputs / Analog output
Group 05	Preset frequency selections.
Group 06	Auto run (auto sequencer) function
Group 07	Start/stop command setup
Group 08	Drive and motor protection
Group 09	Communication function setup
Group 10	PID function setup
Group 11	Performance control functions
Group 12	Digital display & monitor functions
Group 13	Inspection & maintenance function

Parameter notes for Parameter Groups	
*1	Parameter can be adjusted during running mode
*2	Cannot be modified in communication mode
*3	Does not change with factory reset
*4	Read only



<b>Group 00 The basic parameters group</b>					
<b>No.</b>	<b>Description</b>	<b>Range</b>	<b>Factory setting</b>	<b>Unit</b>	<b>Note</b>
00-00	Motor rotation	0: V/F model 1: SLV model	0	-	
00-01	Motor rotation	0: Forward 1: Reverse	0	-	*1
00-02	Main run source selection	0: Keypad	1	-	
		1: External Run/Stop control			
		2: Communication			
00-03	Alternative run source selection	0: Keypad	0	-	
		1: External Run/Stop control			
		2: Communication			
00-04	Operation modes for external terminals	0: Forward/Stop-Reverse/Stop	0	-	
		1: Run/Stop-Reverse/Forward			
		2: 3-Wire control mode-run/stop			
00-05	Main frequency source selection	0: Keypad	2	-	
		1: Potentiometer on keypad			
		2: External AVI analog signal input			
		3: External ACI analog signal input			
		4: External Up/Down frequency control			
		5: Communication setting frequency			
6: PID output frequency					
00-06	Alternative frequency source selection	0: Keypad	0	-	
		1: Potentiometer on keypad			
		2: External AVI analog signal input			
		3: External ACI analog signal input			
		4: External Up/Down frequency control			
		5: Communication setting frequency			
6: PID output frequency.					
00-07	Main and alternative Frequency command modes	0: Main or alternative frequency 1: Main frequency + alternative frequency	0	-	
00-08	Communication frequency command	0.00~599.00		Hz	*4
00-09	Frequency command Save mod (communication mode)	0: Save the frequency before power down 1: Save the communication frequency	0	-	
00-10	Initial frequency selection (keypad mode)	0: By current frequency command	0	-	
		1: By 0 frequency command			
		2: By 00-11			
00-11	Initial Frequency Setpoint	0.00~599.00	50.00/60.00	Hz	
00-12	Frequency upper limit	0.01~599.00	50.00/60.00	Hz	
00-13	Frequency lower limit	0.00~599.99	0.00	Hz	*1
00-14	Acceleration time 1	0.1~3600.0	10.0	s	*1
00-15	Deceleration time 1	0.1~3600.0	10.0	s	*1
00-16	Acceleration time 2	0.1~3600.0	10.0	s	*1
00-17	Deceleration time 2	0.1~3600.0	10.0	s	*1
00-18	Jog frequency	1.00~25.00	2.00	Hz	*1
00-19	Jog acceleration time	0.1~25.5	0.5	s	*1
00-20	Jog deceleration time	0.1~25.5	0.5	s	



Group 01 V/F Pattern selection & setup					
No.	Description	Range	Factory setting	Unit	Note
01-00	Volts/Hz patterns	1~7	1/4	-	
01-01	V/F max voltage	200V: 198.0~256.0 400V: 323.0~528.0	Based on 13-08	Vac	
01-02	Max frequency	0.20~599.00	50.00/60.00	Hz	
01-03	Max frequency voltage ratio	0.0~100.0	100.0	%	
01-04	Mid frequency 2	0.10~599.00	25.00/30.00	Hz	
01-05	Mid frequency voltage ratio 2	0.0~100.0	50.0	%	
01-06	Mid frequency 1	0.10~599.00	10.00/12.00	Hz	
01-07	Mid frequency voltage ratio 1	0.0~100.0	20.0	%	
01-08	Min frequency	0.10~599.00	0.50/0.60	Hz	
01-09	Min frequency voltage ratio	0.0~100.0	1.0	%	
01-10	Volts/Hz curve modification (torque boost) V/F start frequency	0~10.0	0.0	%	*1
01-11	V/F start frequency	0.00~10.00	0.0	Hz	
01-12	No-load oscillation suppression gain	0.0~200.0	0.0	%	
01-13	Motor Hunting Prevention Coefficient	1~8192	800		
01-14	Motor Hunting Prevention Gain	0~100	7	%	
01-15	Motor Hunting Prevention Limit	0.0~100.0	5.0	%	
01-16	Auto-Torque Compensation Filter Coefficient	0.1~1000.0	0.1	ms	
01-17	Auto-Torque Compensation Gain	0~100	0	%	
01-18	Auto-Torque Compensation Frequency	1.30~5.00	2.00	Hz	

Group 02 Motor parameters					
No.	Description	Range	Factory setting	Unit	Note
02-00	Motor no load current	----		A	*3
02-01	Motor rated current (OL1)	----		A	
02-02	Motor rated slip compensation	0.0~100.0	0.0	%	*1
02-03	Motor rated speed	----		Rpm	
02-04	Motor rated voltage	----		Vac	*4
02-05	Motor Rated Power	0~22.0	Motor nameplate	kW	
02-06	Motor Rated Frequency	0~599.0	Motor nameplate		
02-07	Motor Auto Tuning	0: Disable	0		
02-08	Stator Resistor Gain	0~600	by series		
02-09	Rotor Resistor Gain	0~600	by series		
02-10	Reserved	0~200			
02-11	Reserved	0~200			
02-12	Reserved				
02-13	SLV Slip Compensation Gain	0~200			
02-14	SLV Torque Compensation Gain	0~200			
02-15	Low Frequency Torque Gain	0~100			
02-16	SLV Without Load Slip Compensation Gain	0~200			
02-17	SLV With Load Slip Compensation Gain	0~200			
02-18	SLV With Load Torque Compensation Gain	0~200			
02-19	SLV Slip Compensation Select	0: Slip Compensation 1 2: Slip Compensation 2			



**Group 03 Multifunction digital inputs / outputs**

No.	Description	Range	Factory setting	Unit	Note
03-00	Multifunction input term. S1	0: Forward/Stop command or Run/Stop	0	-	
03-01	Multifunction input term. S2	1: Reverse/Stop command or REV/WD	1	-	
03-02	Multifunction input term. S3	2: Preset speed 1 (5-02)	2	-	
03-03	Multifunction input term. S4	3: Preset speed 2 (5-03)	3	-	
03-04	Multifunction input term. S5	4: Preset speed 4 (5-05)	17	-	
		6: Jog forward command			
		7: Jog reverse command			
		8: Up command			
		9: Down command			
		10: Acc/Dec 2			
		11: Acc/Dec disabled			
		12: Main/Alternative run command select			
		13: Main/Alternative frequency command select			
		14: Rapid stop (decel to stop)			
		15: Base block			
		16: Disable PID function			
		17: Reset			
		18: Auto run mode enable			
03-05	Reserved				
03-06	Up/Down frequency band	0.00~5.00	0.00	Hz	
03-07	Up/Down frequency modes	0: When Up/Down is used, the preset frequency is held as the inverter stops, and the UP/Down function is disabled.	0	-	
		1: When Up/Down is used, the preset frequency is reset to 0 Hz as the inverter stops.			
		2: When Up/Down is used, the preset frequency is held as the inverter stops, and the UP/Down is available.			
03-08	S1~S5 scan confirmation	1~400. Number of scan cycles	20	1ms	
03-09	S1~S5 switch type select	xxx0: S1 NO xxx1: S1 NC	00000	-	
		xxx0x: S2 NO xxx1x: S2 NC			
		xx0xx: S3 NO xx1xx: S3 NC			
		x0xxx: S4 NO x1xxx: S4 NC			
		0xxxx: S5 NO 1xxxx: S5 NC			
03-10	Reserved				
03-11	Output relay (RY1)	0: Run	0	-	
		1: Fault			
		2: Setting frequency reached			
		3: Frequency reached (3-13 ± 3-14)			
		4: Output frequency detection 1 (> 3-13)			
		5: Output frequency detection 2 (< 3-13)			
		6: Auto-Restart			
		7: Momentary AC power loss			
		8: Rapid stop			
		9: Base block			
		10: Motor overload protection(OL1)			
		11: Drive overload protection (OL2)			
		12: Reserved			
		13: Output current reached			
		14: Brake control			



Group 03 Multifunction digital inputs / outputs					
No.	Description	Range	Factory setting	Unit	Note
03-12	Reserved				
03-13	Output frequency detection level (Hz)	0.00~599.00	0.00	Hz	*1
03-14	Frequency detection band	0.00~30.00	2.00	Hz	*1
03-15	Output current detection level	0.1~999.9	0.1	A	
03-16	Output current detection period	0.1~10.0	0.1	s	
03-17	External brake engage level	0.00~20.00	0.00	Hz	
03-18	External brake engage level	0.00~20.00	0.00	Hz	
03-19	Relay output function type	0: A (normally open) 1: B (normally close)	0	-	
03-20	Braking Transistor On Level	100/200V : 220-230V	380	VDC	
		240-400V : 380/400V	690	VDC	
		400-800V: 415/460V	780	VDC	
03-21	Brake Transistor Off Level	100/200V : 220-230V	360	VDC	
		240-400V : 380/400V	670	VDC	
		400-800V: 415/460V	760	VDC	

“NO” indicates normally open, “NC” indicates normally closed.

Group 04 Analog signal inputs/Analogue output functions					
No.	Description	Range	Factory setting	Unit	Note
04-00	AVI/ACI analog input signal type select	AVI      ACI	0	-	
		0:0~10V    0~20mA			
		1:0~10V    4~20mA			
		2:2~10V    0~20mA			
		3:2~10V    4~20mA			
04-01	AVI signal verification scan rate	1~400	100	1ms	
04-02	AVI Gain	0~1000	100	%	*1
04-03	AVI Bias	0~100	0	%	*1
04-04	AVI Bias selection	0: Positive    1: Negative	0	-	*1
04-05	AVI Slope	0: Positive    1: Negative	0	-	*1
04-06	ACI Signal verification scan rate	1~400	100	1ms	
04-07	ACI Gain	0~1000	100	%	*1
04-08	ACI Bias	0~100	0	%	*1
04-09	ACI Bias selection	0: Positive    1: Negative	0	-	*1
04-10	ACI Slope	0: Positive    1: Negative	0	-	*1
04-11	Analog output mode (AO)	0: Output frequency 1: Frequency command 2: Output voltage 3: DC bus voltage 4: Motor current	0	-	*1
04-12	Analog output AO Gain (%)	0~1000	100	%	*1
04-13	Analog output AO Bias (%)	0~1000	0	%	*1
04-14	AO Bias selection	0: Positive 1: Negative	0	-	*1
04-15	AO Slope	0: Positive 1: Negative	0	-	*1
04-16	Potentiometer on Keypad Gain	0~1000	100	%	*1
04-17	Potentiometer on Keypad Bias	0~1000	100	%	*1
04-18	Potentiometer on Keypad Bias Selection	0~1000	100	%	*1
04-19	Potentiometer on Keypad Slope	0~1000	100	%	*1



Group 05 Preset frequency selections					
No.	Description	Range	Factory setting	Unit	Note
05-00	Preset speed control mode selection	0: Common Accel/Decel Accel/Decel 1 or 2 apply to all speeds	0	-	
		1: Individual Accel/Decel Accel/ Decel 0-7 apply to the selected preset speeds (Acc0/Dec0~Acc7/Dec7)			
05-01	Preset speed 0 (Keypad Freq)	0.00~599.00	5.00	Hz	
05-02	Preset speed 1 (Hz)		5.00	Hz	*1
05-03	Preset speed 2 (Hz)		10.00	Hz	*1
05-04	Preset speed 3 (Hz)		20.00	Hz	*1
05-05	Preset speed 4 (Hz)		30.00	Hz	*1
05-06	Preset speed 5 (Hz)		40.00	Hz	*1
05-07	Preset speed 6 (Hz)		50.00	Hz	*1
05-08	Preset speed 7 (Hz)		50.00	Hz	*1
05-09 ~ 05-16	Reserved				
05-17	Preset speed 0-Acc time	0.1~3600.0	10.0	s	*1
05-18	Preset speed 0-Dec time		10.0	s	*1
05-19	Preset speed 1-Acc time		10.0	s	*1
05-20	Preset speed 1-Dec time		10.0	s	*1
05-21	Preset speed 2-Acc time		10.0	s	*1
05-22	Preset speed 2-Dec time		10.0	s	*1
05-23	Preset speed 3-Acc time		10.0	s	*1
05-24	Preset speed 3-Dec time		10.0	s	*1
05-25	Preset speed 4-Acctime		10.0	s	*1
05-26	Preset speed 4-Dec time		10.0	s	*1
05-27	Preset speed 5-Acc time		10.0	s	*1
05-28	Preset speed 5-Dec time		10.0	s	*1
05-29	Preset speed 6-Acc time		10.0	s	*1
05-30	Preset speed 6-Dec time		10.0	s	*1
05-31	Preset speed 7-Acc time		10.0	s	*1
05-32	Preset speed 7-Dec time		10.0	s	*1



Group 06 Auto run (Auto Sequencer) function					
No.	Description	Range	Factory setting	Unit	Note
06-00	Auto Run (sequencer) mode selection	0: Disabled. 1: Single cycle. (Continues to run from the unfinished step if restarted). 2: Periodic cycle. (Continues to run from the unfinished step if restarted). 3: Single cycle, then holds the speed of final step to run. (Continues to run from the unfinished step if restarted). 4: Single cycle. (Starts a new cycle if restarted). 5: Periodic cycle. (Starts a new cycle if restarted). 6: Single cycle, then hold the speed of final step to run (Starts a new cycle if restarted).	0	-	
06-01	Auto Run mode frequency command 1	0.00~599.00	0.00	Hz	*1
06-02	Auto Run mode frequency command 2		0.00	Hz	*1
06-03	Auto Run mode frequency command 3		0.00	Hz	*1
06-04	Auto Run mode frequency command 4		0.00	Hz	*1
06-05	Auto Run mode frequency command 5		0.00	Hz	*1
06-06	Auto Run mode frequency command 6		0.00	Hz	*1
06-07	Auto Run mode frequency command 7		0.00	Hz	*1
06-08 ~ 06-15	Reserved				
06-16	Auto Run mode running time setting 0	0.0~3600.0	0.0	s	
06-17	Auto Run mode running time setting 1		0.0	s	
06-18	Auto Run mode running time setting 2		0.0	s	
06-19	Auto Run mode running time setting 3		0.0	s	
06-20	Auto Run mode running time setting 4		0.0	s	
06-21	Auto Run mode running time setting 5		0.0	s	
06-22	Auto Run mode running time setting 6		0.0	s	
06-23	Auto Run mode running time setting 7	0.0	s		
06-24 ~ 06-31	Reserved				
06-32	Auto Run mode running direction 0	0: Stop	0	-	
06-33	Auto Run mode running direction 1	1: Forward 2: Reverse	0	-	



**Group 06 Auto run (Auto Sequencer) function**

No.	Description	Range	Factory setting	Unit	Note
06-34	Auto Run mode running direction 2	0: Stop 1: Forward 2: Reverse	0	-	
06-35	Auto Run mode running direction 3		0	-	
06-36	Auto Run mode running direction 4		0	-	
06-37	Auto Run mode running direction 5		0	-	
06-38	Auto Run mode running direction 6		0	-	
06-39	Auto Run mode running direction 7		0	-	

**Group 07 Start/Stop command setup**

No.	Description	Range	Factory setting	Unit	Note
07-00	Momentary power loss and restart	0: Momentary power loss and restart disable 1: Momentary power loss and restart enable	0	-	
07-01	Auto restart delay time	0.0~800.0	0.0	s	
07-02	Number of auto restart attempts	0~10	0	-	
07-03	Reset mode setting	0: Enable reset only when run command is Off 1: Enable reset when run ommand is On or Off	0	-	
07-04	Direct running after power Up	0: Enable direct run on power up 1: Disable direct run on power up	1	-	
07-05	Delay-ON timer	1.0~300.0	1.0	s	
07-06	DC injection brake start frequency (Hz) in stop mode	0.10~10.00	1.5	Hz	
07-07	DC injection brake level (%) in stop mode	0~20	5	%	
07-08	DC injection brake time (seconds) In stop mode	0.0~25.5	0.5	s	
07-09	Stopping method	0: Deceleration to stop 1: Coast to stop	0		
07-10	DC Braking Level at Start	0~100	0	%	
07-11	DC Braking time at Start	0.0~25.5	0	%	





Group 08 Drive & motor protection functions					
No.	Description	Range	Factory setting	Unit	Note
08-00	Trip prevention selection	xxxx0: Enable trip prevention during acceleration xxxx1: Disable trip prevention during acceleration xxx0x: Enable trip prevention during deceleration xxx1x: Disable trip prevention during deceleration xx0xx: Enable trip prevention in Run mode xx1xx: Disable trip prevention in Run mode x0xxx: Enable over voltage prevention in Run mode x1xxx: Disable over voltage prevention in Run mode	00000	-	
08-01	Trip prevention level during acceleration (%)	50~200	200	Inverter rated current 100%	
08-02	Trip prevention level during deceleration (%)	50~200	200		
08-03	Trip prevention level in Run mode (%)	50~200	200		
08-04	Over voltage prevention level in Run mode	200V: 350~390 400V: 700-780	380/760	VDC	
08-05	Electronic motor overload protection operation mode	xxxx0: Disable Electronic Motor Overload Protection xxxx1: Enable Electronic Motor Overload Protection xxx0x: Motor Overload Cold Start xxx1x: Motor Overload Hot Start xx0xx: Standard Motor xx1xx: Inverter Duty Motor	00001	-	
08-06	Operation after overload protection is activated	0: Coast-to-Stop after overload protection is activated 1: Drive will not trip when overload protection is activated (OL1)	0	-	
08-07	Over heat protection (cooling fan control)	0: Auto (depends on temp.) 1: Operate while in RUN mode 2: Always run 3: Disabled	1	-	
08-08	AVR function (Auto voltage regulation)	0: AVR function enable 1: AVR function disable 2: AVR function disable for stop 3: AVR function disable for deceleration 4: AVR function disable for stop and deceleration. 5: When VDC > (360V/740V), AVR function disable for stop and deceleration.	4	-	
08-09	Input phase lost protection	0: Disabled 1: Enabled	0	-	
08-10	PTC Overheat Function	0: Disabled 1: Decelerate to stop 2: Coast to stop 3: Continue running, when warning level is reached. Coast to stop when protection level is reached			
08-11	PTC Signal Smoothing Time	0.01 ~ 10.00	0.2	Sec	



**Group 08 Drive & motor protection functions**

No.	Description	Range	Factory setting	Unit	Note
08-12	PTC Detection Time Delay	1 ~ 300	60	Sec	
08-13	PTC Protection Level	0.1 ~ 10.0	0.7	Sec	
08-14	PTC Detection Level	0.1 ~ 10.0	0.3	V	
08-15	PTC Warning Level	0.1 ~ 10.0	0.5	V	
08-16	Fan Control Temperature	10.0 ~ 50.0	50	°C	
08-17	Over Current Protection Level	0.0 ~ 60.0	0.0	A	
08-18	Over Current Protection Time	0.0 ~ 1500.0	1.0	Sec	
08-19	Motor Overload Protection Level	0: Motor Overload Protection Level 0 1: Motor Overload Protection Level 1 2: Motor Overload Protection Level 2	0		

**Group 09 Communication function setup**

No.	Description	Range	Factory setting	Unit	Note
09-00	Assigned communication station number	1~32	1	-	*2*3
09-01	RTU code /ASCII code select	0: RTU code 1: ASCII code	0	-	*2*3
09-02	Baud rate setting (bps)	0: 4800 1: 9600 2: 19200 3: 38400	2	bps	*2*3
09-03	Stop bit selection	0: 1 Stop bit 1: 2 Stop bits	0	-	*2*3
09-04	Parity selection	0: Without parity 1: With even parity 2: With odd parity	0	-	*2*3
09-05	Data format selection	0: 8-Bits data 1: 7-Bits data	0	-	*2*3
09-06	Communication time - out detection time	0.0~25.5	0.0	s	
09-07	Communication time-out operation selection	0: Deceleration to stop (00-15: deceleration time 1) 1: Coast to stop 2: Deceleration to stop (00-17: deceleration time 2) 3: Continue operating	0	-	
09-08	Error 6 verification time.	1~20	3		
09-09	Drive transmit delay time (ms)	5~65	5	ms	
09-10	BACmet Station	1~254	1		*2*3



<b>Group 10 PID function setup</b>					
<b>No.</b>	<b>Description</b>	<b>Range</b>	<b>Factory setting</b>	<b>Unit</b>	<b>Note</b>
10-00	PID target value selection (when 00-05\00-06=6 ,this function is enabled)	0: Potentiometer on keypad 1: Analog signal input. (AVI) 2: Analog signal input. (ACI) 3: Frequency set by communication 4: 10-02 given 5: Preset frequency	1	-	*1
10-01	PID feedback value selection	0: Potentiometer on keypad 1: Analog signal input. (AVI) 2: Analog signal input. (ACI) 3: Frequency set by communication	2	-	*1
10-02	PID target (keypad input)	0.0~100.0	50.0	%	*1
10-03	PID mode selection	0: Disabled 1: Deviation D control FWD characteristic. 2: Feedback D control FWD characteristic. 3: Deviation D control reverse characteristic. 4: Feedback D control reverse characteristic.	0	-	
10-04	Feedback gain coefficient	0.00~10.00	1.00	%	*1
10-05	Proportional gain	0.0~0.0	1.0	%	*1
10-06	Integral time	0.0~100.0	10.0	s	*1
10-07	Derivative time	0.00~10.00	0.00	s	*1
10-08	PID offset	0: Positive 1: Negative	0	-	*1
10-09	PID offset adjust	0~109	0	%	*1
10-10	PID output lag filter time	0.0~2.5	0.0	s	*1
10-11	Feedback loss detection mode	0: Disabled 1: Drive keeps running after feedback loss 2: Drive stops after feedback loss			
10-12	Feedback loss detection level	0~100	0	%	
10-13	Feedback loss detection delay time	0.0~25.5	1.0	s	
10-14	Integration limit value	0~109	100	%	*1
10-15	Integral value resets to zero when feedback signal equals the target value	0: Disabled 1: 1 Second 30: 30 Seconds (0~30)	0	s	
10-16	Allowable integration error margin (units) (1unit = 1/8192)	0~100	0	-	
10-17	PID sleep frequency level	0.00~599.00	0.00	Hz	
10-18	PID sleep function delay time	0.0~25.5	0.0	s	
10-19	PID wake up frequency level	0.00~599.00	0.00	Hz	
10-20	PID wake up function delay time	0.0~25.5	0.0	s	
10-21	Max PID feedback setting	0~999	100	-	*1
10-22	Min PID feedback setting	0~999	0	-	*1



**Group 11 Performance control functions**

No.	Description	Range	Factory setting	Unit	Note
11-00	Reverse operation control	0: Reverse command is enabled 1: Reverse command is disabled	0	-	
11-01	Carrier frequency (kHz)	1~16	5	KHz	
11-02	Carrier mode selection	0: Mode 0, 3 phase PWM modulation 1: Mode 1, 2 phase PWM modulation 2: Mode 2, 2 phase random PWM modulation	0	-	
11-03	Carrier frequency reduction by temperature rise	0: Disabled 1: Enabled	0	-	
11-04	S-Curve acc 1	0.0~4.0	0.00	s	
11-05	S-Curve acc 2	0.0~4.0	0.00	s	
11-06	S-Curve dec 3	0.0~4.0	0.00	s	
11-07	S-Curve dec 4	0.0~4.0	0.00	s	
11-08	Skip frequency 1	0.00~599.00	0.00	Hz	*1
11-09	Skip frequency 2	0.00~599.00	0.00	Hz	*1
11-10	Skip frequency 3	0.00~599.00	0.00	Hz	*1
11-11	Skip frequency bandwidth (±)	0.00~30.00	0.00	Hz	*1
11-12	Regeneration Prevention Function	0: Disable 1: Enable 2: Enable (during constant speed only)	0		
11-13	Regeneration Prevention Voltage Level	300.0~400.0	380.0		
11-14	Regeneration Prevention Frequency Limit	0.00~15.00	3.00	V	
11-15	Regeneration Prevention Voltage Gain	0~200	100	Hz	
11-16	Regeneration Prevention Frequency Gain	0~200	100	%	
11-17	Speed loop proportion gain	0~65535	10000	%	
11-18	Speed loop integration gain	0~65535	800		
11-29	Speed loop differential gain	0~65535	0		
11-20	Stop Key Selection	0: Enable Stop Key when Run Command not from Keypad 1: Disable Stop Key when Run Command not from Keypad	0		



<b>Group 12 Digital display &amp; monitor functions</b>					
<b>No.</b>	<b>Description</b>	<b>Range</b>	<b>Factory setting</b>	<b>Unit</b>	<b>Note</b>
12-00	Extended display mode	00000~77777. Each digit can be set to 0 to 7	00000	-	*1
		0: Default display (frequency & parameters)			
		1: Output current			
		2: Output voltage			
		3: DC voltage			
		4: Temperature of Heat Sink			
		5: PID feedback			
		6: Analog signal Input. (AVI)			
7: Analog signal Input. (ACI)					
12-01	PID feedback display format	0: Integer (xxx)	0	-	*1
		1: One decimal place (xx.x)			
		2: Two decimal places (x.xx)			
12-02	PID feedback display unit setting	0: xxx--	0	-	*1
		1: xxxpb (pressure)			
		2: xxxfl (flow)			
12-03	Custom units (line speed) value	0~65535	1500/1800	RPM	*1
12-04	Custom units (line speed) display mode	0: Drive output frequency is displayed	0	-	*1
		1: Line speed. Integer. (xxxxx)			
		2: Line speed. One decimal place (xxxx.x)			
		3: Line speed. Two decimal places (xxx.xx)			
		4: Line speed. Three decimal places (xx.xxx)			



**Group 12 Digital display & monitor functions**

No.	Register No.	Description	Range	Factory setting	Unit	Modbus example value	Note
12-05	0C05H	Inputs and output logic status display (S1 to S5) & RY1		----	-		*4
12-06		Output Power	---	0.0	Kw		
12-07		Motor Current Percentage	---	0	%		

**Group 13 Inspection & maintenance functions**

No.	Description	Range	Factory setting	Unit	Note
13-00	Drive horse power code	----	-	-	*3
13-01	Software version	----	-	-	*3*4
13-02	Fault log (last 3 faults)	----	-	-	*3*4
13-03	Accumulated operation time 1 1	0~23	-	Hour	*3
13-04	Accumulated operation time 1 2	0~65535	----	Day	*3
13-05	Accumulated operation time mode	0: Time under power 1: Run mode time only	0	-	*3
13-06	Parameter lock	0: Enable all functions 1: Preset speeds 05-01~05-08 cannot be changed 2: All functions cannot be changed except for preset speeds 05-01~05-08 3: Disable all function	0	-	
13-07	Parameter lock code	00000~65535	00000	-	
13-08	Reset drive to factory settings	1150: Initialization (50Hz,220V/380V) 1160: Initialization (60Hz,220V/380V) 1250: Initialization (50Hz,230V/400V) 1260: Initialization (60Hz,230V/460V) 1350: Initialization (50Hz,220V/415V) 1360: Initialization (60Hz,230V/400V)	00000	-	



## Annex 1: Consignes de sécurité

- Le produit est un lecteur conçu pour commander un moteur à induction triphasé. lire attentivement ce manuel pour garantir le bon fonctionnement, la sécurité et pour se familiariser avec les fonctions d'entraînement.
- Le lecteur est un appareil électrique / électronique et doit être installé et géré par un personnel qualifié
- Une mauvaise manipulation peut entraîner un fonctionnement incorrect, cycle de vie plus court, ou l'échec de ce produit ainsi que le moteur.
- Tous les documents sont sujets à changement sans préavis. Soyez sûr d'obtenir les dernières éditions de l'utilisation ou visitez notre site Web
- Lire le manuel d'instructions avant de procéder à l'installation, les connexions (câblage), le fonctionnement ou l'entretien et l'inspection.
- Vérifiez que vous avez une bonne connaissance de l'entraînement et de vous familiariser avec les consignes de sécurité et les précautions avant de procéder à fonctionner le lecteur.
- Prêter attention aux consignes de sécurité indiquées par l'avertissement et symbole Attention .

<b>Avertissement</b>	ignorer les informations indiquées par le symbole d'avertissement peut entraîner la mort ou des blessures graves.
<b>Attention</b>	ignorer les informations indiquées par le symbole de mise en garde peut entraîner des blessures mineures ou modérées et / ou des dommages matériels importants.

### 1.1 Avant d'alimenter le disque dur

<b>Avertissement</b>
Le circuit principal doit être correctement câblée. Pour les terminaux monophasés d'approvisionnement de l'utilisation des intrants (R/L1, T/L3) et de trois bornes d'entrée de l'utilisation de l'offre de phase (R/L1, S/L2, T/L3). U/T1, V/T2, W/T3 ne doivent être utilisés pour connecter le moteur. Raccordement de l'alimentation d'entrée à l'un des U/T1, V/T2 W/T3 ou bornes risque d'endommager le lecteur.

<b>Attention</b>
<ul style="list-style-type: none"> <li>• Pour éviter que le couvercle ne se désengage ou de tout autre dommage physique, ne portez pas le lecteur par son couverture. Soutenir le groupe par son dissipateur de chaleur lors du transport. Une mauvaise manipulation peut endommager le lecteur ou blesser le personnel, et doit être évitée.</li> <li>• Pour éviter que les risques d'incendie, ne pas installer le lecteur sur ou à proximité d'objets inflammables. Installer sur des objets ininflammables comme les surfaces métalliques.</li> <li>• Si plusieurs disques sont placés dans le même panneau de contrôle, fournir une ventilation adéquate pour maintenir la température en dessous de 40 ° C/104 ° F (50 ° C/122 ° F sans housse de protection) pour éviter la surchauffe ou incendie.</li> <li>• Lors d'un retrait ou d'installation de l'opérateur numérique, éteignez-le d'abord, puis de suivre les instructions de ce manuel pour éviter les erreurs de l'opérateur ou de la perte de l'affichage causé par des connexions défectueuses.</li> </ul>

<b>Avertissement</b>
Lors d'un retrait ou d'installation de l'opérateur numérique, éteignez-le d'abord, puis de suivre les instructions de ce manuel pour éviter les erreurs de l'opérateur ou de la perte de l'affichage causé par des connexions défectueuses....



## 1.2 Câblage

### Avertissement

- Coupez toujours l'alimentation électrique avant de procéder à l'installation d'entraînement et le câblage des terminaux utilisateurs.
- Le câblage doit être effectué par un personnel qualifié / électricien certifié.
- Assurez-vous que le lecteur est correctement mis à la terre. (220V Classe: impédance de mise à la terre doit être inférieure à 100Ω Classe 440V: Impédance de mise à la terre doit être inférieure à 10Ω.)
- vérifier et tester mes circuits d'arrêt d'urgence après le câblage. (L'installateur est responsable du câblage.)
- Ne touchez jamais de l'entrée ou de lignes électriques de sortie permettant directement ou toute entrée ou de lignes de puissance de sortie à venir en contact avec le boîtier d'entraînement.
- Ne pas effectuer un test de tenue en tension diélectrique (mégohmmètre) sur le disque dur ou cela va entraîner des dommages de lecture pour les composants semi-conducteurs.

### Attention

- La tension d'alimentation appliquée doit se conformer à la tension d'entrée spécifiée par le lecteur. (Voir la section signalétique du produit)
- Raccorder la résistance de freinage et de l'unité de freinage sur les bornes assignées.
- Ne pas brancher une résistance de freinage directement sur les bornes CC P (+) et N (-), sinon risque d'incendie.
- Utilisez des recommandations de la jauge de fil et les spécifications de couple. (Voir Wire Gauge et la section de spécification de couple)
- Ne jamais brancher l'alimentation d'entrée aux bornes onduleur de sortie U/T1, V/T2, W/T3.
- Ne pas brancher un contacteur ou interrupteur en série avec le variateur et le moteur.
- Ne branchez pas un facteur condensateur de correction de puissance ou supprimeur de tension à la sortie du variateur
- S'assurer que l'interférence générée par l'entraînement et le moteur n'a pas d'incidence sur les périphériques.

## 1.3 Avant l'opération

### Avertissement

- Assurez-vous que la capacité du disque correspond aux paramètres de notation avant d'alimenter.
- Réduire le paramètre de la fréquence porteuse si le câble du variateur au moteur est supérieure à 80 pi (25 m). Un courant de haute fréquence peut être générée par la capacité parasite entre les câbles et entraîner un déclenchement de surintensité du variateur, une augmentation du courant ou d'une lecture actuelle inexactes.
- Veillez à installer tous les couvercles avant de l'allumer. Ne retirez pas les capots pendant que l'alimentation du lecteur est allumé, un choc électrique peut se produire autrement.
- Ne pas actionner d'interrupteurs avec les mains mouillées, un choc électrique pourrait survenir autrement.
- Ne touchez pas les bornes d'entraînement lorsqu'il est alimenté, même si le lecteur est arrêté, un choc électrique pourrait survenir autrement.

## 1.4 Configuration Paramètre

### Attention

- Ne branchez pas une charge pour le moteur tout en effectuant un auto-tune.
- Assurez-vous que le moteur peut fonctionner librement et il y a suffisamment d'espace autour du moteur lors de l'exécution d'un auto-tune rotation.





## 1.5 Opération

### Avertissement

- Veillez à installer tous les couvercles avant de l'allumer. Ne retirez pas les capots pendant que l'alimentation du lecteur est allumé, un choc électrique peut se produire autrement.
- Ne pas brancher ou débrancher le moteur pendant le fonctionnement. Le variateur pourrait se déclencher et ainsi endommager le lecteur.
- Les opérations peuvent commencer soudainement si une alarme ou un défaut est réarmé avec un ordre de marche active. Assurez-vous qu'un ordre de marche est actif lors de la réinitialisation de l'alarme ou de défaut, autrement des accidents peuvent se produire.
- Ne pas actionner d'interrupteurs avec les mains mouillées, un choc électrique pourrait survenir .
- Un interrupteur d'urgence externe indépendant est fourni, qui s'arrête en urgence vers le bas la sortie de l'onduleur en cas de danger.
- Si le redémarrage automatique après une récupération d'énergie est activée, le variateur démarrera automatiquement après le rétablissement du courant.
- Assurez-vous qu'il est sûr de faire fonctionner le variateur et le moteur avant d'effectuer un auto-tune rotation.
- Ne touchez pas les bornes d'entraînement lorsqu'il est alimenté même si l'onduleur s'est arrêté, un choc électrique pourrait survenir .
- Ne pas contrôler les signaux sur les circuits pendant que le lecteur est en marche.
- Après la mise hors tension, le ventilateur de refroidissement peut continuer à fonctionner pendant un certain temps.

### Attention

- Ne touchez pas les composants générant de la chaleur tels que radiateurs et des résistances de freinage.
- Vérifiez soigneusement la performance du moteur ou de la machine avant d'utiliser à grande vitesse, sous peine de blessure.
- Notez les réglages des paramètres liés à l'unité de freinage lorsque applicable.
- Ne pas utiliser la fonction de freinage d'entraînement pour un maintien mécanique, sous peine de blessure.
- Ne pas contrôler les signaux sur les circuits pendant que le lecteur est en marche.

## 1.6 Entretien, Inspection et remplacement

### Avertissement

- Attendre un minimum de 5 minutes après que l'alimentation a été débranchée avant de commencer une inspection. Vérifiez également que le voyant de charge est éteint et que la tension du bus cc a chuté au-dessous de 25Vdc.
- Ne jamais toucher les bornes à haute tension dans le lecteur.
- Assurez-vous que l'alimentation du lecteur est débranché avant de démonter le lecteur.
- Seul le personnel autorisé peuvent faire l'entretien, l'inspection et les opérations de remplacement. (Enlevez les bijoux en métal tels que les montres et les bagues et utiliser des outils isolés.)

### Attention

- Le variateur peut être utilisé dans un environnement avec une gamme de température allant de 14 ° -104 ° F (10-40 ° C) et l'humidité relative de 95% sans condensation.
- Le variateur doit être utilisé dans un environnement sans poussière, gaz, vapeur et humidité.

## 1.7 Mise au rebut du variateur

### Avertissement

- Jeter cet appareil avec soin comme un déchet industriel et selon les réglementations locales nécessaires.
- Les condensateurs du circuit principal d'entraînement et circuits imprimés sont considérés comme des déchets dangereux et ne doivent pas être brûlés.
- The Plastic enclosure and parts of the drive such as the top cover board will release harmful gases if burned.

## OUR SALES NETWORK IN EUROPE

**AUSTRIA** - Carlo Gavazzi GmbH  
Ketzergergasse 374, A-1230 Wien  
Tel: +43 1 888 4112  
Fax: +43 1 889 10 53  
office@carlogavazzi.at

**BELGIUM** - Carlo Gavazzi NV/SA  
Mechelsesteenweg 311, B-1800 Vilvoorde  
Tel: +32 2 257 4120  
Fax: +32 2 257 41 25  
sales@carlogavazzi.be

**DENMARK** - Carlo Gavazzi Handel A/S  
Over Hadstenvej 40, DK-8370 Hadsten  
Tel: +45 89 60 6100  
Fax: +45 86 98 15 30  
handel@gavazzi.dk

**FINLAND** - Carlo Gavazzi OY AB  
Petaksentie 2-4, FI-00630 Helsinki  
Tel: +358 9 756 2000  
Fax: +358 9 756 20010  
myynti@gavazzi.fi

**FRANCE** - Carlo Gavazzi Sarl  
Zac de Paris Nord II, 69, rue de la Belle  
Etoile, F-95956 Roissy CDG Cedex  
Tel: +33 1 49 38 98 60  
Fax: +33 1 48 63 27 43  
french.team@carlogavazzi.fr

**GERMANY** - Carlo Gavazzi GmbH  
Pforstr. 10-14  
D-64293 Darmstadt  
Tel: +49 6151 81000  
Fax: +49 6151 81 00 40  
info@gavazzi.de

**GREAT BRITAIN** - Carlo Gavazzi UK Ltd  
4.4 Frimley Business Park,  
Frimley, Camberley, Surrey GU16 7SG  
Tel: +44 1 276 854 110  
Fax: +44 1 276 682 140  
sales@carlogavazzi.co.uk

**ITALY** - Carlo Gavazzi SpA  
Via Milano 13, I-20020 Lainate  
Tel: +39 02 931 761  
Fax: +39 02 931 763 01  
info@gavazziacbu.it

**NETHERLANDS** - Carlo Gavazzi BV  
Wijkemeerweg 23,  
NL-1948 NT Beverwijk  
Tel: +31 251 22 9345  
Fax: +31 251 22 60 55  
info@carlogavazzi.nl

**NORWAY** - Carlo Gavazzi AS  
Melkeveien 13, N-3919 Porsgrunn  
Tel: +47 35 93 0800  
Fax: +47 35 93 08 01  
post@gavazzi.no

**PORTUGAL** - Carlo Gavazzi Lda  
Rua dos Jerónimos 38-B,  
P-1400-212 Lisboa  
Tel: +351 21 361 7060  
Fax: +351 21 362 13 73  
carlogavazzi@carlogavazzi.pt

**SPAIN** - Carlo Gavazzi SA  
Avda. Iparraguirre, 80-82,  
E-48940 Leioa (Bizkaia)  
Tel: +34 94 480 4037  
Fax: +34 94 431 6081  
gavazzi@gavazzi.es

**SWEDEN** - Carlo Gavazzi AB  
V:a Kyrkogatan 1,  
S-652 24 Karlstad  
Tel: +46 54 85 1125  
Fax: +46 54 85 11 77  
info@carlogavazzi.se

**SWITZERLAND** - Carlo Gavazzi AG  
Verkauf Schweiz/Vente Suisse  
Sumpfstrasse 3,  
CH-6312 Steinhausen  
Tel: +41 41 747 4535  
Fax: +41 41 740 45 40  
info@carlogavazzi.ch

## OUR SALES NETWORK IN THE AMERICAS

**USA** - Carlo Gavazzi Inc.  
750 Hastings Lane,  
Buffalo Grove, IL 60089, USA  
Tel: +1 847 465 6100  
Fax: +1 847 465 7373  
sales@carlogavazzi.com

**CANADA** - Carlo Gavazzi Inc.  
2660 Meadowvale Boulevard,  
Mississauga, ON L5N 6M6, Canada  
Tel: +1 905 542 0979  
Fax: +1 905 542 22 48  
gavazzi@carlogavazzi.com

**MEXICO** - Carlo Gavazzi Mexico S.A. de C.V.  
Calle La Montaña no. 28, Fracc. Los Pastores  
Naucaflan de Juárez, EDOMEX CP 53340  
Tel & Fax: +52.55.5373.7042  
mexicosales@carlogavazzi.com

**BRAZIL** - Carlo Gavazzi Automação Ltda.  
Av. Francisco Matarazzo, 1752  
Conj 2108 - Barra Funda - São Paulo /SP  
CEP 01401-000  
Tel: +55 11 3052 0832  
Fax: +55 11 3057 1753  
info@carlogavazzi.com.br

## OUR SALES NETWORK IN ASIA AND PACIFIC

**SINGAPORE** - Carlo Gavazzi Automation  
Singapore Pte. Ltd.  
61 Tai Seng Avenue  
#05-06 UE Print Media Hub  
Singapore 534167  
Tel: +65 67 466 990  
Fax: +65 67 461 980  
info@carlogavazzi.com.sg

**MALAYSIA** - Carlo Gavazzi Automation  
(M) SDN. BHD.  
D12-06-G, Block D12,  
Pusat Perdagangan Dana 1,  
Jalan PJU 1A/46, 47301 Petaling Jaya,  
Selangor, Malaysia.  
Tel: +60 3 7842 7299  
Fax: +60 3 7842 7399  
sales@gavazzi-asia.com

**CHINA** - Carlo Gavazzi Automation  
(China) Co. Ltd.  
Unit 2308, 23/F,  
News Building, Block 1, 1002  
Middle Shennan Zhong Road,  
Shenzhen, China  
Tel: +86 755 83699500  
Fax: +86 755 83699300  
sales@carlogavazzi.cn

**HONG KONG** - Carlo Gavazzi  
Automation Hong Kong Ltd.  
Unit 3 12/F Crown Industrial Bldg.,  
106 How Ming St., Kwun Tong,  
Kowloon, Hong Kong  
Tel: +852 23041228  
Fax: +852 23443689

## OUR COMPETENCE CENTRES AND PRODUCTION SITES

**DENMARK** - Carlo Gavazzi Industri A/S  
Hedsten

**MALTA** - Carlo Gavazzi Ltd  
Zejtun

**ITALY** - Carlo Gavazzi Controls SpA  
Belluno

**LITHUANIA** - Uab Carlo Gavazzi  
Industri Kaunas

**CHINA** - Carlo Gavazzi Automation  
(Kunshan) Co., Ltd.  
Kunshan

## HEADQUARTERS

Carlo Gavazzi Automation SpA  
Via Milano, 13 - I-20020  
Lainate (MI) - **ITALY**  
Tel: +39 02 931 761  
info@gavazziautomation.com



Printed on 100% recycled paper  
produced using  
post consumer de-inked waste.

**CARLO GAVAZZI**  
Automation Components

*Energy to Components!*

www.gavazziautomation.com

